

LOCATION MAP
N.T.S.

PROPOSED EDADVANCE BUILDING

95-104 GROVE STREET
TORRINGTON, CT 06790

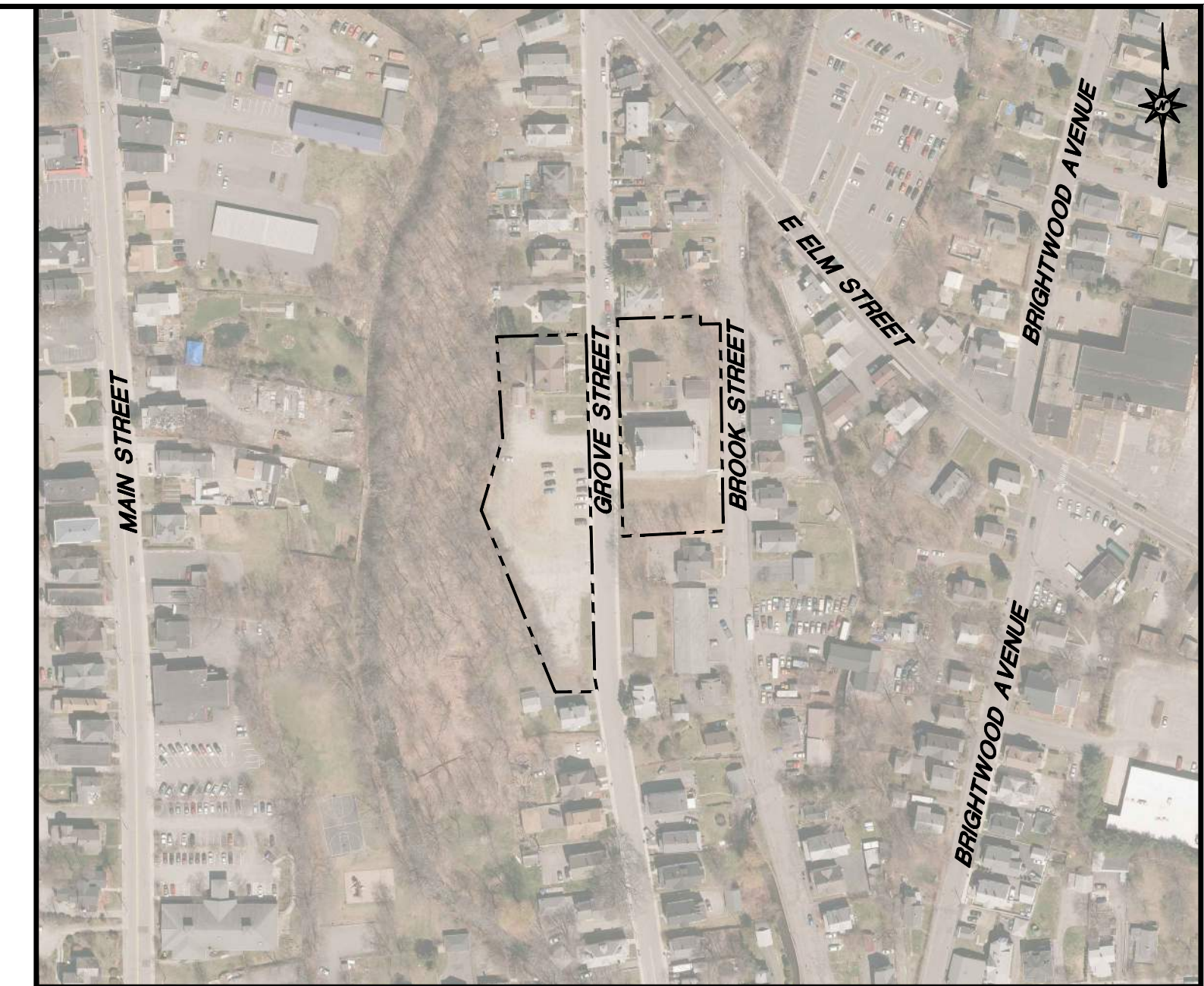

VICINITY MAP
SCALE: 1"=200'

PREPARED FOR:
A. SECONDINO & SON, INC.
PO BOX 622 / 21 ACORN ROAD
BRANFORD, CT 06405

CONTENTS

	TITLE SHEET
	PROPERTY SURVEY (BY OTHERS)
DM-1	DEMOLITION PLAN
SP-1	SITE PLAN
TT-1	TRUCK TURN PLAN
GD-1	GRADING AND DRAINAGE PLAN
SU-1	SITE UTILITIES PLAN
EC-1	SEDIMENT AND EROSION CONTROL PLAN
EC-2	SEDIMENT AND EROSION CONTROL NOTES
EC-3	SEDIMENT AND EROSION CONTROL DETAILS
LL-1	LANDSCAPE PLAN
LL-2	LANDSCAPE NOTES AND DETAILS
GN-1	GENERAL NOTES
DN-1 TO DN-6	DETAIL SHEETS

PREPARED BY:



355 RESEARCH PARKWAY
MERIDEN, CONNECTICUT 06450
(203) 630-1406
(203) 630-2615 Fax

FOR PERMITTING PURPOSES ONLY
NOT RELEASED FOR CONSTRUCTION

DEVELOPER:
A. SECONDINO & SON, INC.
PO BOX 622 / 21 ACORN ROAD
BRANFORD, CT 06405

OWNER:
SACRED HEART CHURCH
160 MAIN STREET
TORRINGTON, CT 06790

SUBCONSULTANTS: _____



DATES
ISSUE DATE: MARCH 10, 2023
REVISION:

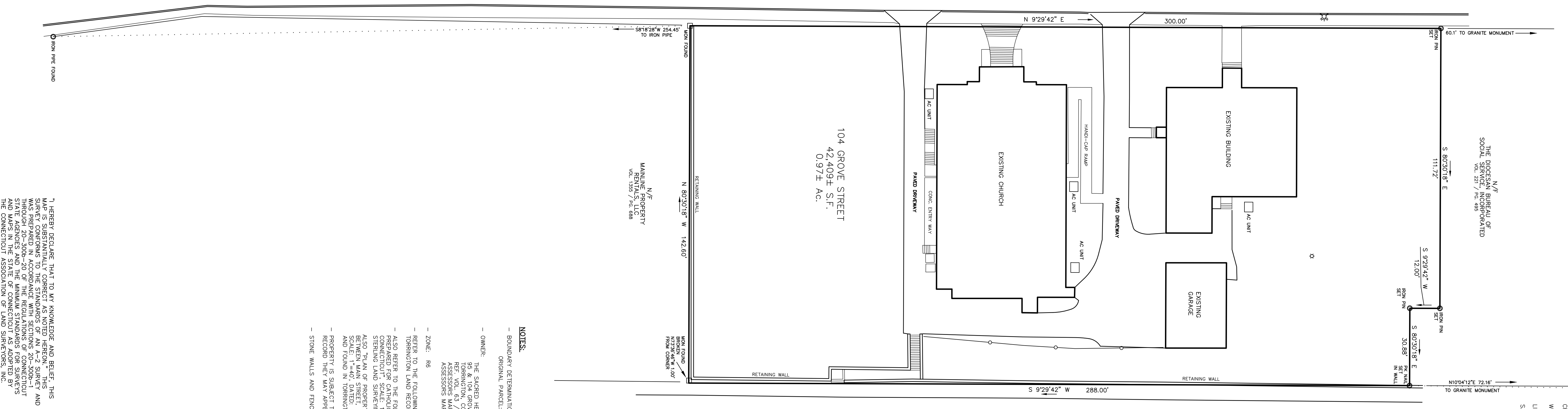
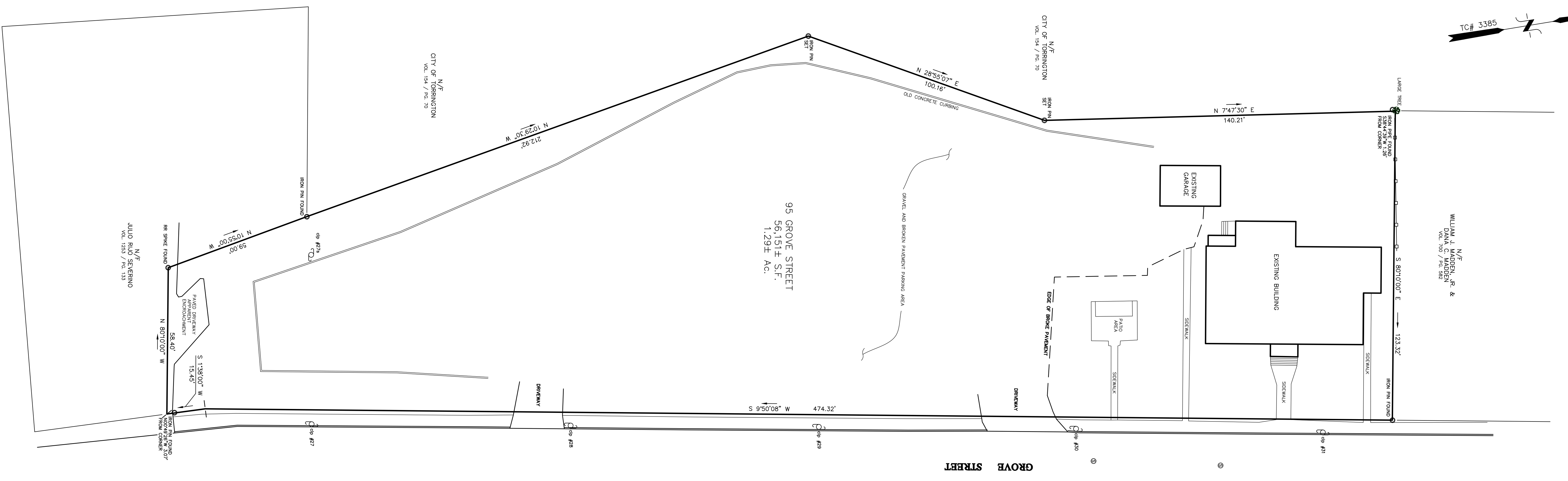

LEGEND

PROPERTY LINE	—
EXISTING MONUMENT	□
EXISTING IRON PIN OR PIPE	○
PROPOSED IRON PIN OR PIPE	●
UTILITY POLE W/ANCHOR	⊕
CHAIN FENCE	—○—○—○—
WOOD FENCE	—□—□—□—
LIGHT POLE	⊙
SANITARY MANHOLE	⊗

- NOTES:**
- BOUNDARY DETERMINATION CATEGORY: DEPENDENT RESURVEY
 - ORIGINAL PARCEL:
 - OWNER: THE SACRED HEART CHURCH OF THE TOWN OF TORRINGTON, CONNECTICUT 06790
REF. VOL. 63 / PG. 397 & VOL. 75 / PG. 404
ASSESSORS MAP 118 / BLOCK 16 / LOT 5
 - ZONE: R8
 - REFER TO THE FOLLOWING MAPS: TOW# 484, 561, 2806, 3385 ON FILE IN TORRINGTON LAND RECORDS.
 - ALSO REFER TO THE FOLLOWING MAP: IMPROVEMENT LOCATION SURVEY PREPARED FOR CATHOLIC CHARITIES, 119 GROVE STREET, TORRINGTON, CONNECTICUT, SCALE: 1"=20', DATED: DECEMBER, 2006, PREPARED BY: STERLING LAND SURVEYING AND FOUND IN TORRINGTON ENGINEERING DEPT.
 - THE "L" MARKED POINTS ARE FOUND IN TORRINGTON ENGINEERING DEPT. BETWEEN LAMAR STREET EAST FERRY & GROVE STREET, TORRINGTON, CONN. SCALE: 1"=40', DATED: AUGUST, 1918, PREPARED BY: W.A. WILSTON, C.E. AND FOUND IN TORRINGTON ENGINEERING DEPT.
 - PROPERTY IS SUBJECT TO EASEMENTS, COVENANTS AND RESTRICTIONS AS OF RECORD THEY MAY APPEAR.
 - STONE WALLS AND FENCES MAY VARY FROM PRINCIPLE COURSES SHOWN.

I HEREBY DECLARE THAT TO MY KNOWLEDGE AND BELIEF, THIS MAP IS ESSENTIALLY CORRECT AS NOTED HEREON. THIS SURVEY CONFORMS TO THE STANDARDS OF AN A-2 SURVEY AND WAS PREPARED IN ACCORDANCE WITH SECTIONS 20-300-1 THROUGH 20-300-10 OF THE CONSTITUTION AND STATUTES OF THE STATE AGENCIES AND THE MINIMUM STANDARDS FOR SURVEYS AND MAPS IN THE STATE OF CONNECTICUT AS ADOPTED BY THE CONNECTICUT ASSOCIATION OF LAND SURVEYORS, INC. ON SEPTEMBER 26, 1996.

KENNETH S. HRICA P.E.L.S. CT Lic. #18966
NOT VALID WITHOUT ORIGINAL SEAL

PROPERTY SURVEY
PREPARED FOR
BDADVANCE

95 & 104 GROVE STREET
TORRINGTON, CONNECTICUT

Hrica Associates LLC
Engineers

Surveyors

Kenneth S. Hrica, P.E., L.S.
P.O. Box 1861
Litchfield, Connecticut 06759

860-597-2112 (Business)
860-597-0491 (Residential)
hricasurveyors@comcast.net

DATE:	10/6/2022	MAP #:	0976
SCALE:	1"=20 FT.	SHEET #:	1 OF 1
DRAWING:	220976	DRAWN BY:	LPJ
PROJECT #:	22-0976	CHECKED BY:	KSH

ZONING INFORMATION (LOT 1)

LOCATION: TORRINGTON, CONNECTICUT				
ZONE: R6 (GENERAL RESIDENCE ZONE)				
USE: SCHOOL (USE PERMITTED BY SPECIAL EXCEPTION)				
ITEM #	ITEM	REQUIREMENTS	PROPOSED	VARIANCE
1	MINIMUM LOT AREA	7,500 S.F.	56,151 S.F. (1.29 AC.)	NO
2	MINIMUM LOT WIDTH	75 FEET	489.8 FEET	NO
3	MINIMUM LOT FRONTAGE	NONE REQUIRED	489.8 FEET	NO
4	MINIMUM FRONT SETBACK	25 FEET	25.0 FEET	NO
5	MINIMUM SIDE SETBACK	MINIMUM OF 8 FEET ON ONE SIDE, TOTAL OF BOTH SIDES = 20 FEET	5.1 FEET	NO(1)
6	MINIMUM REAR SETBACK	30 FEET	(2) 20% REDUCTION RESULTS IN 24 FT SETBACK	NO
7	MAXIMUM BUILDING HEIGHT	60 FEET	32 FEET	NO
8	MAXIMUM IMPERVIOUS SURFACE	50 PERCENT	±44.4 PERCENT	NO

(1) PRE-EXISTING NONCONFORMING SETBACK AT NORTH SIDE OF CONVENT
 (2) PER SECTION 4.1.9 WHERE AN EXISTING BUILDING IS IN VIOLATION OF FRONT, SIDE, OR REAR YARD SETBACKS OR BUFFER AND THE APPLICANT HAS REQUESTED AND EXPANSION OF THE BUILDING, THE COMMISSION MAY, BY SPECIAL EXCEPTION, ALLOW A REDUCTION OF THE SETBACK, AND/OR BUFFER FOR SUCH BUILDING EXPANSION TO THE LESSER OF: A. TWENTY PERCENT OF THE REQUIRED SETBACK OR BUFFER; OR B. THE SETBACK OF THE EXISTING BUILDING.

PARKING INFORMATION (LOT 1)

ITEM #	ITEM	REQUIREMENTS	PROPOSED	VARIANCE
1	BUILDING SIZE	NONE REQUIRED	13,079.5 S.F.	NO
2	PARKING REQUIRED	ELEMENTARY SCHOOL: 1.1 SPACE PER EMPLOYEE OR 1 SPACE PER 5 SEATS IN THE AUDITORIUM, WHICHEVER IS GREATER (37 EMPLOYEES * 1.1 = 40.7) TOTAL REQUIRED = 41	ON-SITE: 26 SPACES ON LOT 2 = 15 SPACES TOTAL = 41 SPACES	NO
3	MINIMUM HANDICAPPED PARKING SPACES REQUIRED	2 SPACES	2 SPACES	NO
4	MINIMUM PARKING DIMENSIONS	9 FEET X 18 FEET	9 FEET X 18 FEET	NO
5	MINIMUM AISLE WIDTH	24 FEET - 2-WAY 12 FEET - 1-WAY PARALLEL PKG 18 FEET - 1-WAY 60' PKG 20 FEET - W-WAY 90' PKG	18 FEET - 1-WAY 60' PKG 24 FEET - 1-WAY 90' PKG	NO
6	MINIMUM FRONT SETBACK	25 FEET	25 FEET	NO
7	MINIMUM SIDE SETBACK	25 FEET	25 FEET	NO
8	MINIMUM REAR SETBACK	25 FEET	25 FEET	NO

NOTE: LANDSCAPE ISLAND REQUIRED EVERY 15 PARKING SPACES

ZONING INFORMATION (LOT 2)

LOCATION: TORRINGTON, CONNECTICUT				
ZONE: R6 (GENERAL RESIDENCE ZONE)				
USE: SCHOOL (USE PERMITTED BY SPECIAL EXCEPTION)				
ITEM #	ITEM	REQUIREMENTS	PROPOSED	VARIANCE
1	MINIMUM LOT AREA	7,500 S.F.	42,409 S.F. (0.97 AC.)	NO
2	MINIMUM LOT WIDTH	75 FEET	300 FEET	NO
3	MINIMUM LOT FRONTAGE	NONE REQUIRED	300 FEET	NO
4	MINIMUM FRONT SETBACK	25 FEET	15.9 FEET	NO(1)
5	MINIMUM SIDE SETBACK	MINIMUM OF 8 FEET ON ONE SIDE, TOTAL OF BOTH SIDES = 20 FEET	57.4 FEET	NO
6	MINIMUM REAR SETBACK	30 FEET	28.5 FEET	NO(1)
7	MAXIMUM BUILDING HEIGHT	60 FEET	<60 FEET	NO
8	MAXIMUM IMPERVIOUS SURFACE	50 PERCENT	±52.3 PERCENT	YES

(1) PRE-EXISTING NONCONFORMING SETBACK AT CHURCH BUILDING

PARKING INFORMATION (LOT 2)

ITEM #	ITEM	REQUIREMENTS	PROPOSED	VARIANCE
1	BUILDING SIZE	NONE REQUIRED	N/A	NO
2	PARKING REQUIRED	CHURCH: 1 SPACE PER 500 SF (OFFICE) 9,116 SF/500 = 18.2 SPACES RECTORY: 1 SPACE PER 500 SF (OFFICE) 5,064 SF/500 = 10.1 SPACES TOTAL REQUIRED = 28 SPACES	18 SPACES	NO(3)
3	MINIMUM HANDICAPPED PARKING SPACES REQUIRED	2 SPACES	2 SPACES	NO
4	MINIMUM PARKING DIMENSIONS	9 FEET X 18 FEET	9 FEET X 18 FEET	NO
5	MINIMUM AISLE WIDTH	24 FEET - 2-WAY 12 FEET - 1-WAY PARALLEL PKG 18 FEET - 1-WAY 60' PKG 20 FEET - W-WAY 90' PKG	24 FEET - 2-WAY 15 FEET - 1-WAY PARALLEL PKG 18 FEET - 1-WAY 60' PKG	NO
6	MINIMUM FRONT SETBACK	25 FEET	25 FEET	NO
7	MINIMUM SIDE SETBACK	25 FEET	25 FEET	NO
8	MINIMUM REAR SETBACK	25 FEET	20 FEET (1)	NO

(1) EXISTING REAR PARKING IS 15-FT FROM PROPERTY LINE. PROPOSED PARKING IS AT 20-FT
 (2) NOTE: LANDSCAPE ISLAND REQUIRED EVERY 15 PARKING SPACES
 (3) PARKING WAIVER REQUESTED

SITE PLAN LEGEND

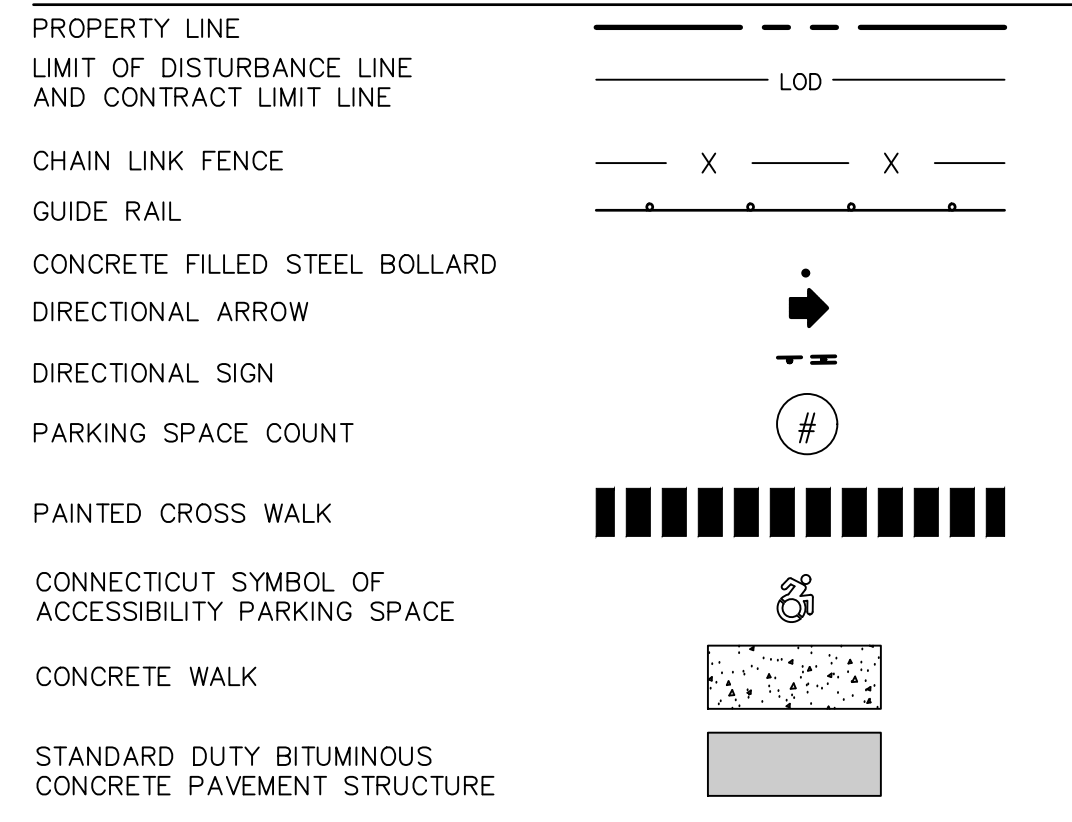

SIGN LEGEND

SIGN NO.	CT-DOT NO. OR MUTCD NO.	LEGEND
A	31-0532	STOP 30"
B	31-0629	WETLAND BUFFER
C	31-0648	VAN ACCESSIBLE
D	31-1120	DO NOT ENTER

NOTE: HANDICAPPED SIGNS TO BE INSTALLED IN PIPE BOLLARDS (SEE DETAIL). ALL HANDICAP SIGNAGE TO CONFORM TO LATEST BUILDING CODE.

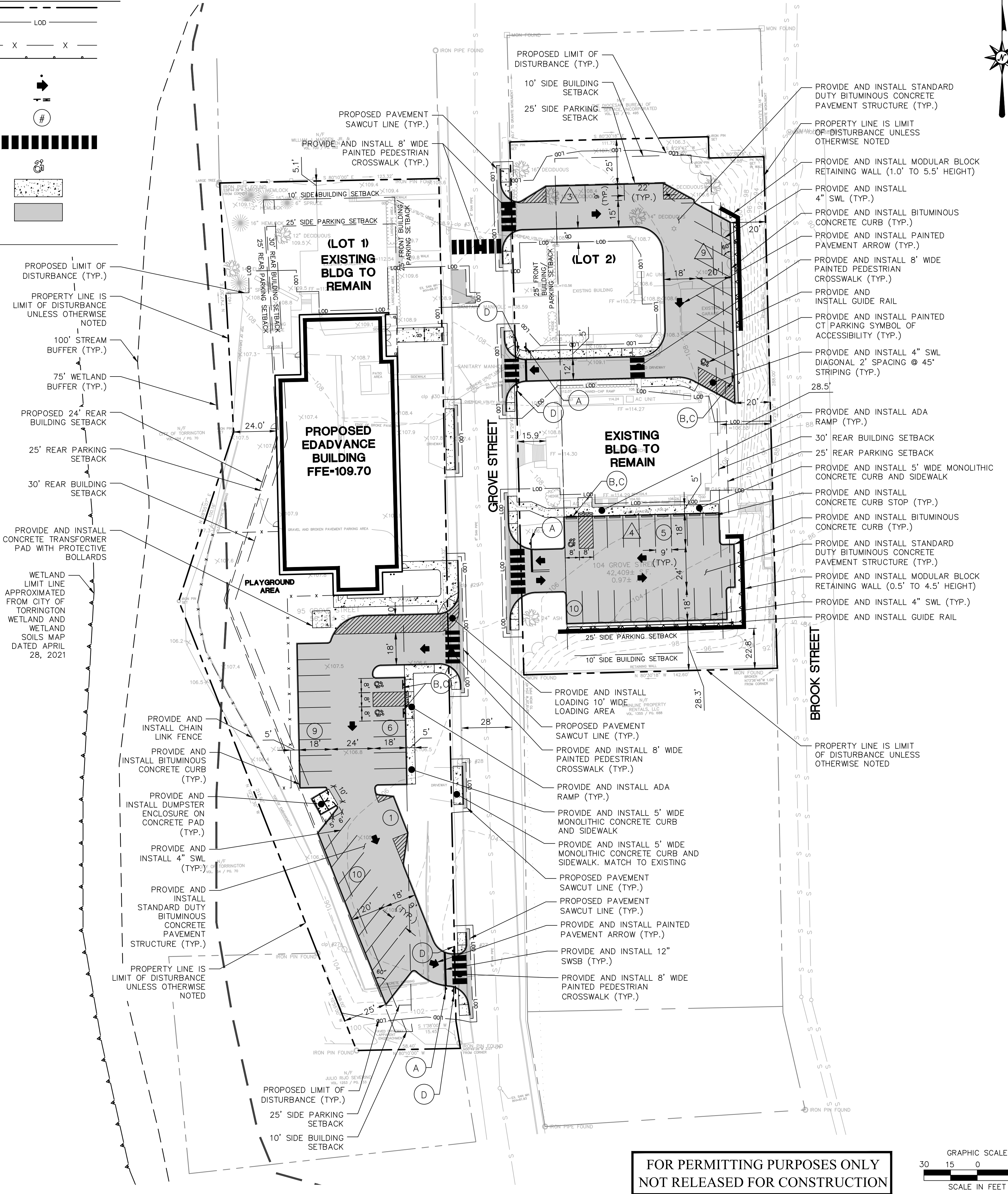

FOR PERMITTING PURPOSES ONLY
 NOT RELEASED FOR CONSTRUCTION

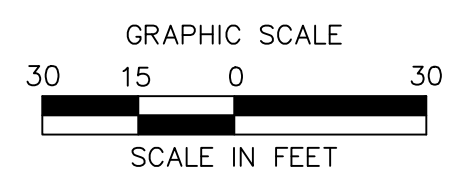

PROPOSED EDADVANCE BUILDING
 95-104 GROVE STREET
 TORRINGTON, CONNECTICUT

Designed	C.J.L.
Drawn	C.J.L.
Reviewed	J.J.S.
Scale	1"=30'
Project No.	2202472
Date	03/10/2023
CAD File:	SP220247201
Title	SITE PLAN
Sheet No.	SP-1

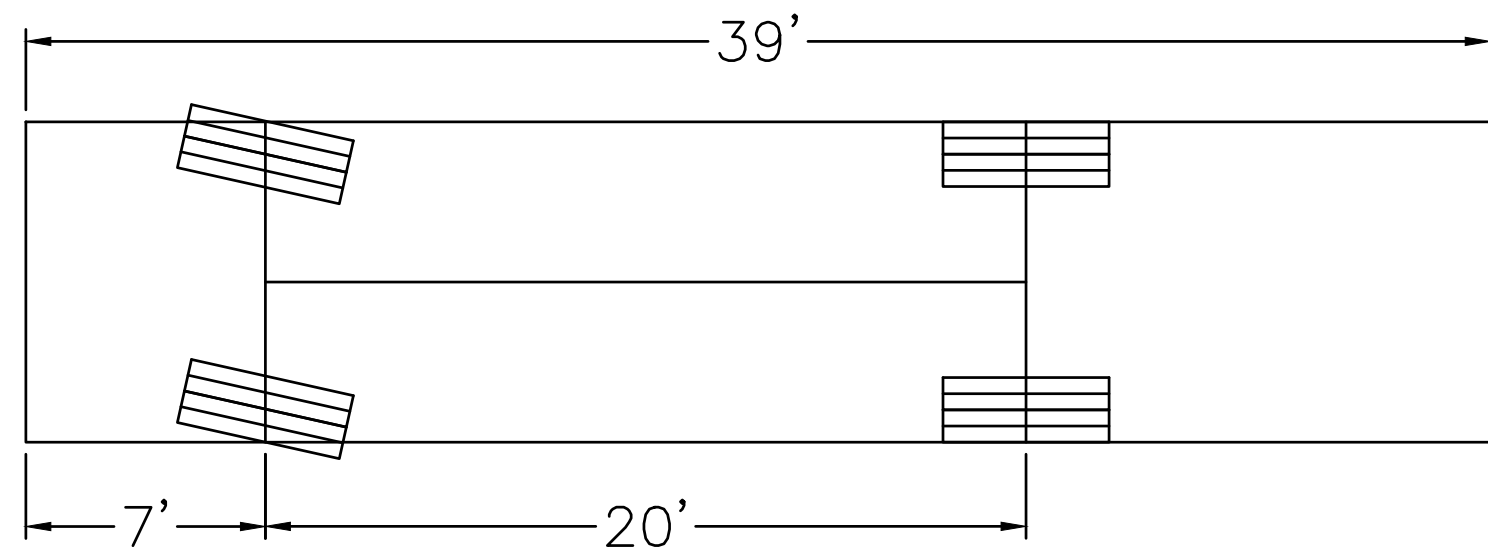

AERIAL FIRE TRUCK
 OVERALL LENGTH 39.0'
 OVERALL WIDTH 8.167'
 OVERALL BODY HEIGHT 7.5'
 MIN BODY GROUND CLEARANCE 0.750'
 TRACK WIDTH 8.167'
 LOCK-TO-LOCK TIME 5.00s
 MAX TO WHEEL ANGLE 45°

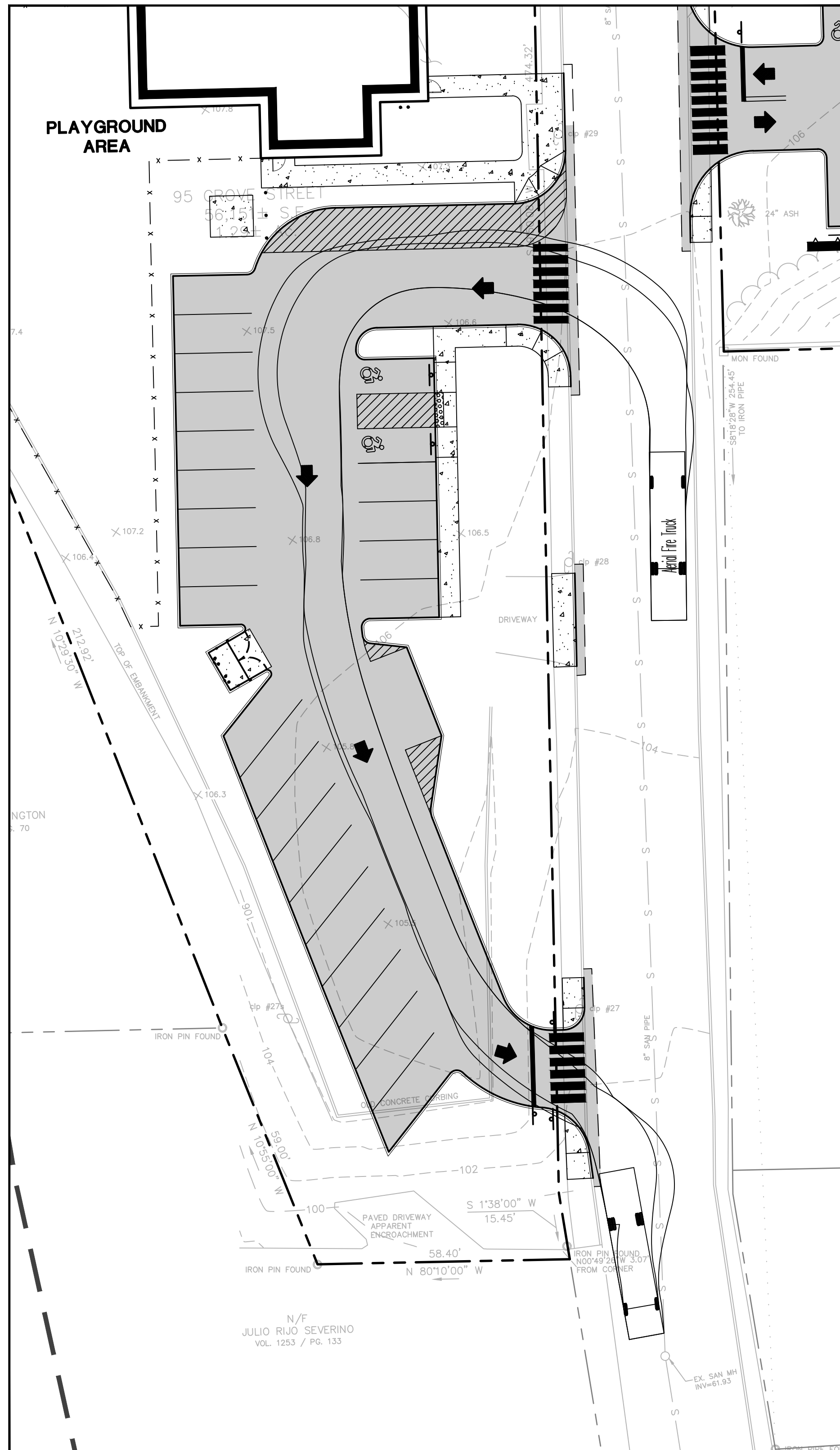
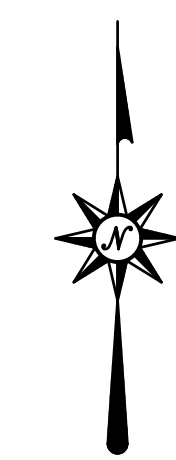

95 GROVE STREET (LOT 1) DRIVEWAY

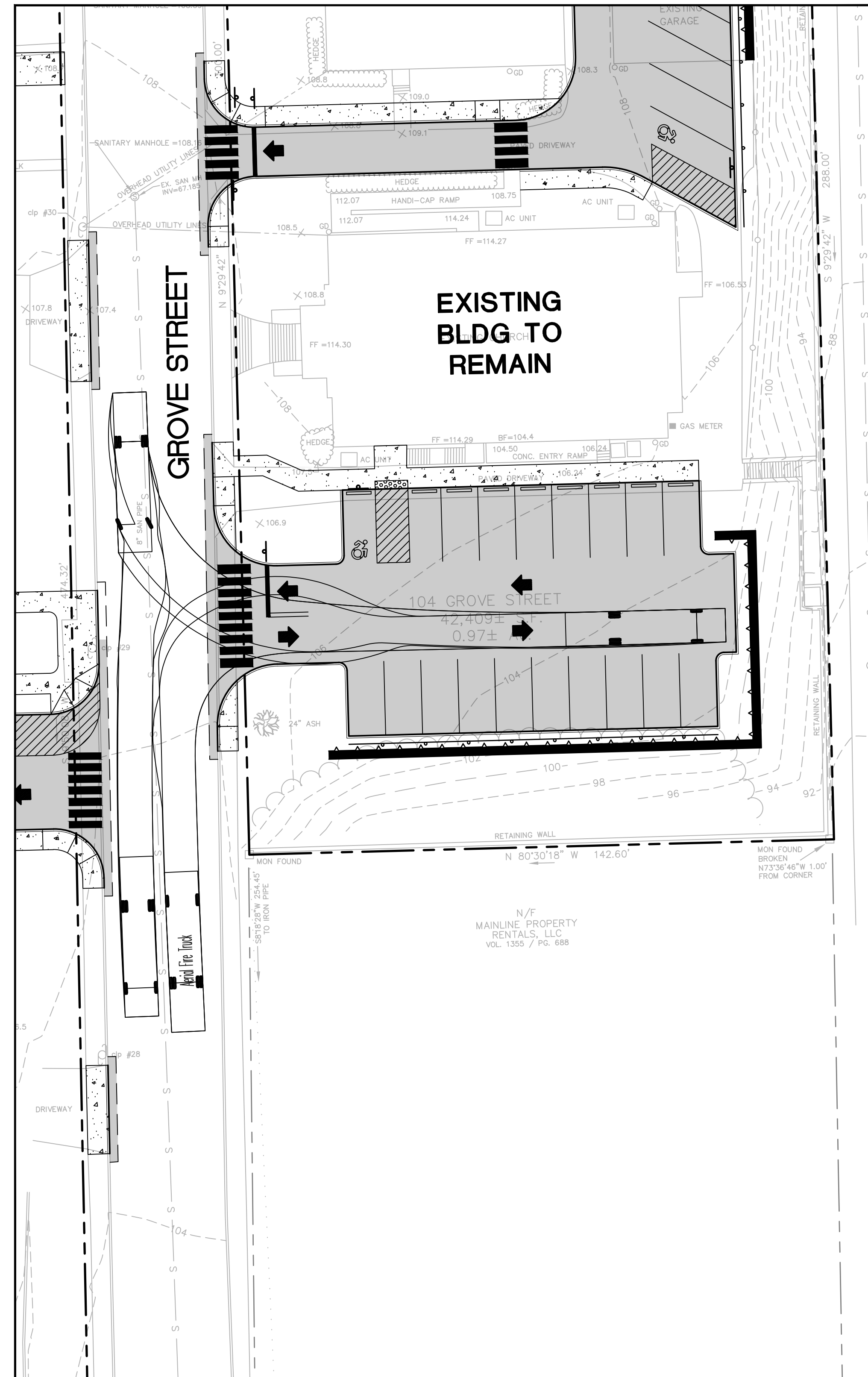

104 GROVE STREET (LOT 2) SOUTH DRIVEWAY

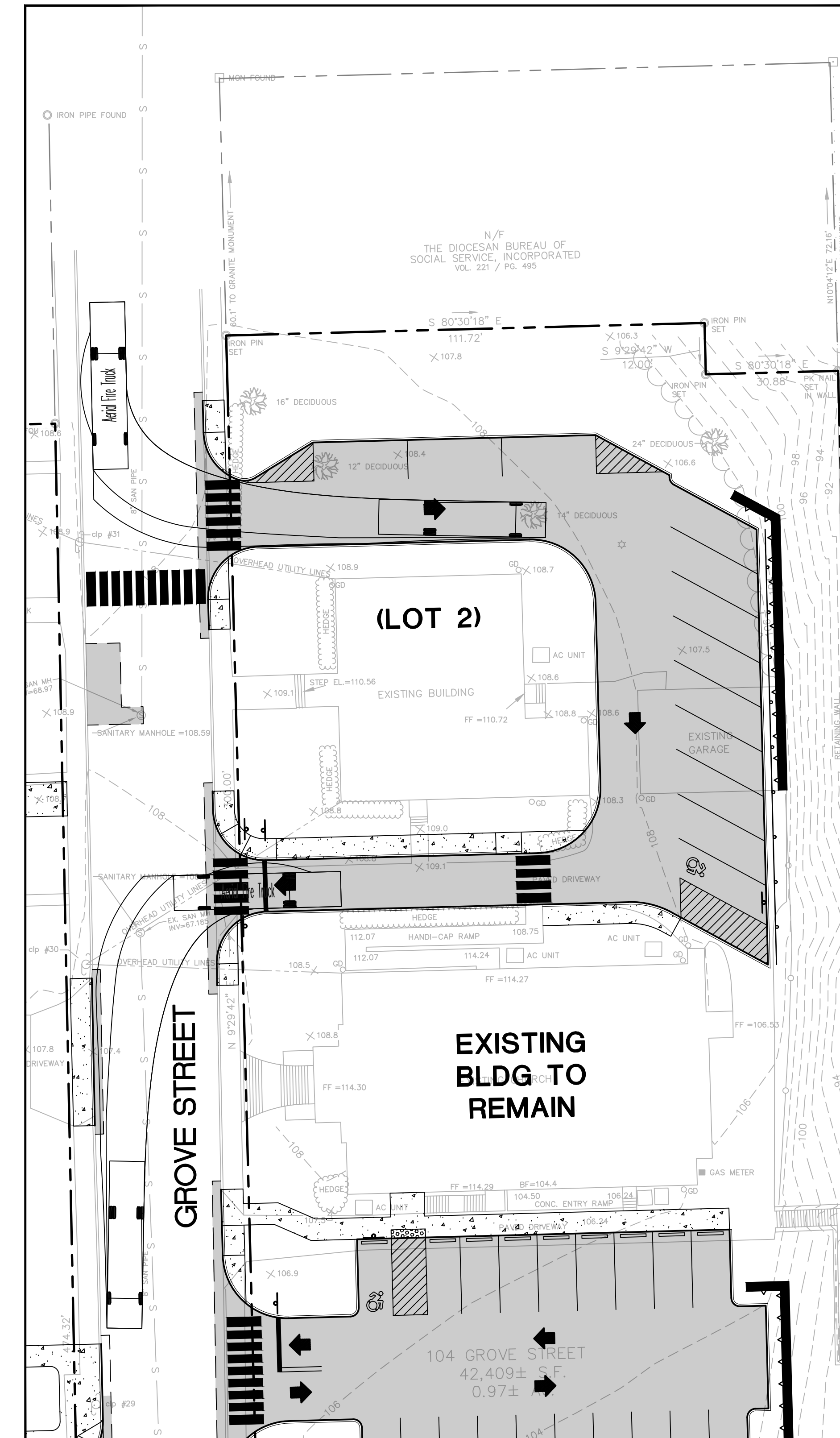

104 GROVE STREET (LOT 2) NORTH DRIVEWAY

FOR PERMITTING PURPOSES ONLY
 NOT RELEASED FOR CONSTRUCTION

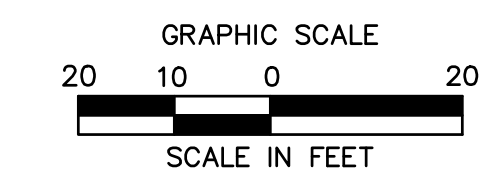

355 Research Parkway
 Meriden, CT 06450
 (203) 630-1406



PROPOSED EDADVANCE BUILDING
 95-104 GROVE STREET
 TORRINGTON, CONNECTICUT

REV. NO.	DATE	DESC.

Designed M.A.G.
 Drawn M.A.G.
 Reviewed J.J.S.
 Scale 1"=20'
 Project No. 2202472
 Date 03/10/2023
 CAD File: T1220247201

Title
TRUCK TURN PLAN

Sheet No.

TT-1

3/10/2023, CHELSEAS, C:\WORKSPACE\2023\T1\DWG\T1220247201.DWG, T1, 24X36, 250C.

Sheet No.: T1220247201 - AC20230229-201 - T1220247201

© 2023 BL COMPANIES, INC. THESE DRAWINGS SHALL NOT BE UTILIZED BY ANY PERSON, FIRM OR CORPORATION WITHOUT THE SPECIFIC WRITTEN PERMISSION OF BL COMPANIES.

SITE UTILITIES LEGEND

PROPERTY LINE	---
LIMIT OF DISTURBANCE LINE AND CONTRACT LIMIT LINE	--- LOD ---
ELECTRIC LINE	— E — E —
ELECTRIC AND TELECOMMUNICATIONS LINES	— E/T —
GAS LINE	— G — G —
WATER LINE	— W — W —
SANITARY SEWER LINE	— S —
OVERHEAD LINE	— OH — OH —
TRANSFORMER	⊠
HYDRANT	⊗
UTILITY POLE	⊙
SANITARY MANHOLE	⊙
SANITARY CLEANOUT	⊙
WATER VALVE	⊙
GATE VALVE	⊙
THRUST BLOCK	⊙
GREASE TRAP	⊙
OUTLET CONTROL STRUCTURE	⊙
HYDRODYNAMIC SEPARATOR	⊙
STORM LINE	---
CATCH BASIN	⊙
STORM MANHOLE	⊙

NOTES

CONTRACTOR SHALL CONFIRM LOCATION, SIZE, CONDITION AND ELEVATION OF ALL UTILITY LATERAL STUBS, WATER MAINS, GAS MAINS AND ELECTRICAL SERVICES PRIOR TO CONSTRUCTION.

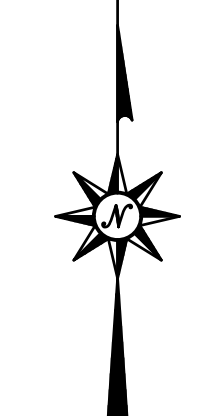
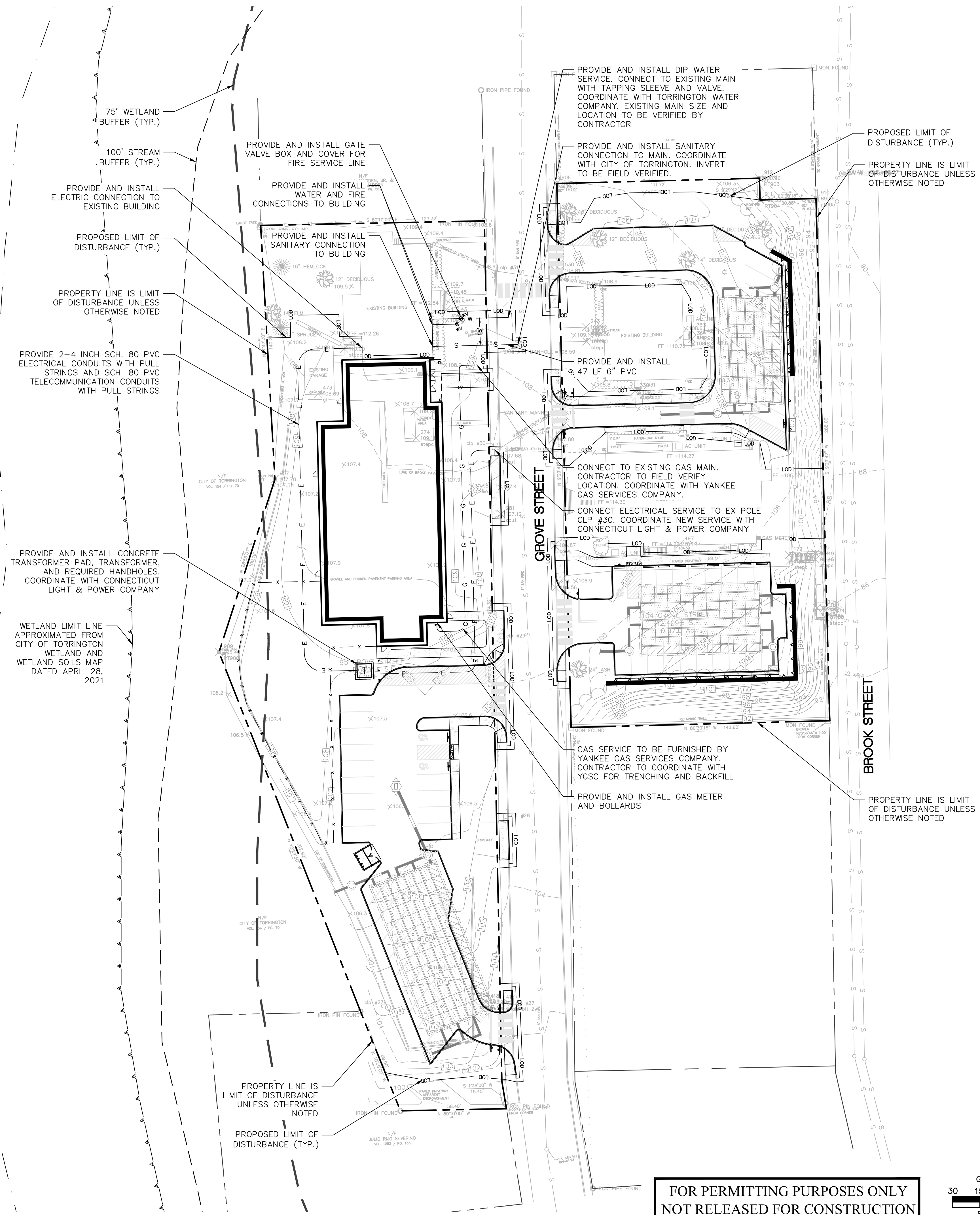

PROPOSED EDADVANCE BUILDING
95-104 GROVE STREET
TORRINGTON, CONNECTICUT

REVISIONS	Desc.
No.	Date
Designed	C.J.L.
Drawn	C.J.L.
Reviewed	J.J.S.
Scale	1"=30'
Project No.	2202472
Date	03/10/2023
CAD File:	SU220247201
Title	SITE UTILITIES PLAN
Sheet No.	

**FOR PERMITTING PURPOSES ONLY
NOT RELEASED FOR CONSTRUCTION**

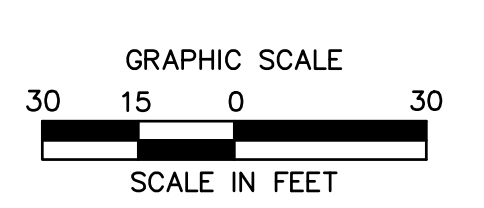

3/10/2023, CHELSEAS, C:\ORIS\2022\2202472\DWG\SU1220247201.DWG, SU1 24x36, 80%

© 2023 BL COMPANIES, INC. THESE DRAWINGS SHALL NOT BE UTILIZED BY ANY PERSON, FIRM OR CORPORATION WITHOUT THE SPECIFIC WRITTEN PERMISSION OF BL COMPANIES.

EROSION CONTROL LEGEND:

CONTROL MEASURE	ILLUSTRATION
INLET PROTECTION AT CATCH BASINS	
SILT FENCE	
CONSTRUCTION ENTRANCE	
LIMIT OF DISTURBANCE LINE AND CONTRACT LIMIT LINE	
EROSION CONTROL BLANKET	
STOCKPILE AREA WITH DOUBLE ROW OF SILT FENCE	

SOIL TYPE

238C HINCKLEY-URBAN LAND COMPLEX,
3 TO 15 PERCENT SLOPES (HSG A)

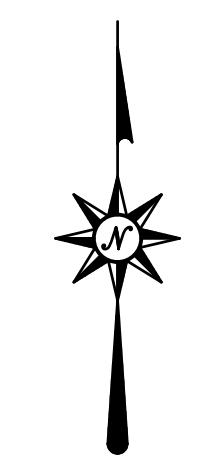
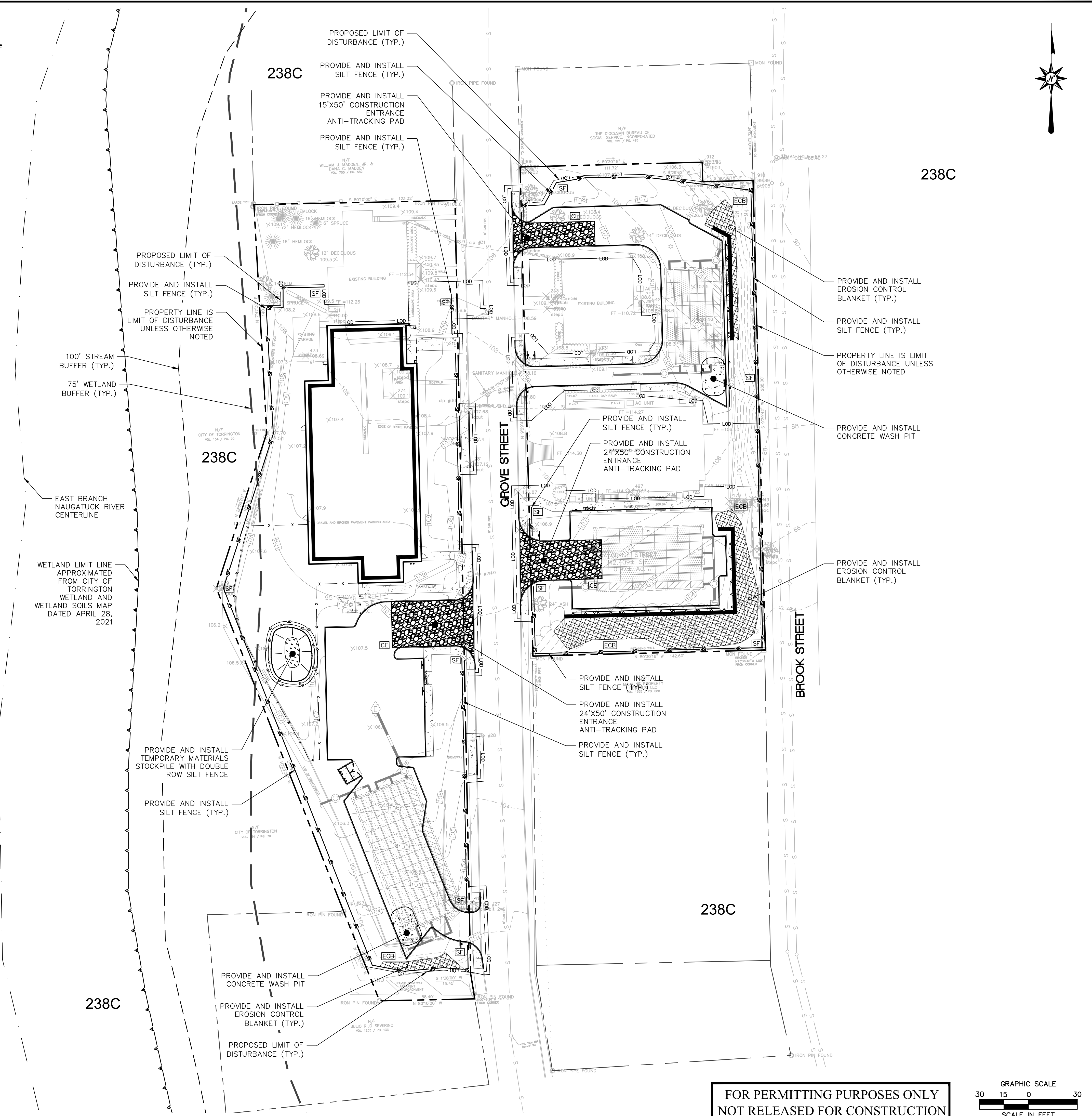

355 Research Parkway
Meriden, CT 06450
(203) 630-1406



PROPOSED EDADVANCE BUILDING
95-104 GROVE STREET
TORRINGTON, CONNECTICUT

REVISIONS	Desc.
No.	Date

Designed M.A.G.
Drawn M.A.G.
Reviewed J.J.S.
Scale 1"=30'
Project No. 2202472
Date 03/10/2023
CAD File: EC220247201

Title
SEDIMENT AND EROSION CONTROL PLAN

Sheet No.

FOR PERMITTING PURPOSES ONLY
NOT RELEASED FOR CONSTRUCTION

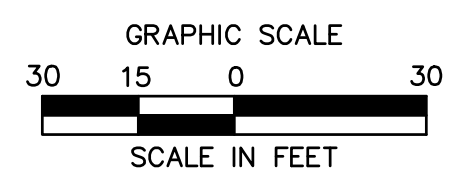

3/10/2023, CHEURUX, C:\ORIS\2023\20230427\DWG\EC220247201.DWG (EC) 1:2400A, 300C.

© 2023 BL COMPANIES, INC. THESE DRAWINGS SHALL NOT BE UTILIZED BY ANY PERSON, FIRM OR CORPORATION WITHOUT THE SPECIFIC WRITTEN PERMISSION OF BL COMPANIES.

ZONING INFORMATION (LOT 1)

LOCATION: TORRINGTON, CONNECTICUT				
ZONE: R6 (GENERAL RESIDENCE ZONE)				
USE: SCHOOL (USE PERMITTED BY SPECIAL EXCEPTION)				
ITEM #	ITEM	REQUIREMENTS	PROPOSED	VARIANCE
1	SEC 5.11.3. LANDSCAPING REQUIREMENTS FOR FRONTYARDS	A.1. ONE DECIDUOUS TREE IS REQUIRED FOR EVERY FORTY LINEAR FEET - OR PORTION THEREOF - OF FRONT YARD 278 FT (EXCLUDE DRIVEWAY) / 40 = 7 STREET TREES REQUIRED	COMPLIES 7 STREET TREES PROPOSED	NO
		A.2. FIVE SHRUBS ARE REQUIRED FOR EVERY FORTY LINEAR FEET - OR PORTION THEREOF - OF FRONT YARD 278 FT (EXCLUDE DRIVEWAY) / 40 X 5 = 35 SHRUBS REQUIRED	35 SHRUBS PROPOSED	NO
2	SEC 5.11.4. LANDSCAPING REQUIREMENTS FOR PARKING AREAS	B. LOTS WITH 15 OR MORE PARKING SPACES EACH LANDSCAPED ISLAND SHALL BE A MINIMUM OF 18 FEET IN LENGTH AND NINE FEET IN WIDTH. EACH LANDSCAPED ISLAND SHALL CONTAIN A DECIDUOUS TREE.	COMPLIES	NO
3	SEC 5.11.5. BUFFER REQUIREMENTS	A.5. EXISTING VEGETATION MAY BE USED TO SATISFY THE BUFFER REQUIREMENTS PROVIDED EQUIVALENT VISUAL PROTECTION IS PROVIDED AND THE BUFFER IS A MINIMUM OF FIFTEEN FEET WIDE	COMPLIES WITH 15 FEET WIDE BUFFER AROUND PARKING AREA	NO

ZONING INFORMATION (LOT 2)



LOCATION: TORRINGTON, CONNECTICUT				
ZONE: R6 (GENERAL RESIDENCE ZONE)				
USE: SCHOOL (USE PERMITTED BY SPECIAL EXCEPTION)				
ITEM #	ITEM	REQUIREMENTS	PROPOSED	VARIANCE
1	SEC 5.11.3. LANDSCAPING REQUIREMENTS FOR FRONTYARDS	A.1. ONE DECIDUOUS TREE IS REQUIRED FOR EVERY FORTY LINEAR FEET - OR PORTION THEREOF - OF FRONT YARD 235 FT (EXCLUDE DRIVEWAY) / 40 = 6 STREET TREES REQUIRED	COMPLIES 6 STREET TREES PROPOSED (2 EXISTING TREES + 4 NEW STREET TREES)	NO
		A.2. FIVE SHRUBS ARE REQUIRED FOR EVERY FORTY LINEAR FEET - OR PORTION THEREOF - OF FRONT YARD 235 FT (EXCLUDE DRIVEWAY) / 40 X 5 = 30 SHRUBS REQUIRED	30 SHRUBS PROPOSED	NO
2	SEC 5.11.4. LANDSCAPING REQUIREMENTS FOR PARKING AREAS	B. LOTS WITH 15 OR MORE PARKING SPACES EACH LANDSCAPED ISLAND SHALL BE A MINIMUM OF 18 FEET IN LENGTH AND NINE FEET IN WIDTH. EACH LANDSCAPED ISLAND SHALL CONTAIN A DECIDUOUS TREE.	COMPLIES	NO
3	SEC 5.11.5. BUFFER REQUIREMENTS	A.5. EXISTING VEGETATION MAY BE USED TO SATISFY THE BUFFER REQUIREMENTS PROVIDED EQUIVALENT VISUAL PROTECTION IS PROVIDED AND THE BUFFER IS A MINIMUM OF FIFTEEN FEET WIDE	COMPLIES WITH 15 FEET WIDE BUFFER AROUND PARKING AREA	NO

PLANT SCHEDULE

TREES	CODE	QTY	BOTANICAL NAME	COMMON NAME	SIZE	CONTAINER
AR	11		ACER RUBRUM 'ARMSTRONG'	ARMSTRONG RED MAPLE	2.5" CAL.	B&B
PY	5		PRUNUS X YEDOENSIS 'AKEBONO'	AKEBONO YOSHINO CHERRY	2.5" CAL.	B&B
TO	3		THUJA OCCIDENTALIS 'SMARAGD'	EMERALD GREEN ARBORVITAE	7"-8" HT.	B&B
ZS	7		ZELKOVA SERRATA 'AUTUMN GLOW'	AUTUMN GLOW JAPANESE ZELKOVA	2.5" CAL.	B&B
SHRUBS	CODE	QTY	BOTANICAL NAME	COMMON NAME	SIZE	CONTAINER
AM	9		ARONIA MELANOCARPA 'UCONNAM165'	LOW SCAPE MOUND®BLACK CHOKEBERRY	2 GAL.	CONT.
CS	14		CORNUS STOLONIFERA 'FARROW'	ARCTIC FIRE®RED TWIG DOGWOOD	2 GAL.	CONT.
IG	41		ILEX GLABRA 'SHAMROCK'	SHAMROCK INKBERRY HOLLY	2 GAL.	CONT.
IV	29		ILEX VERTICILLATA	WINTERBERRY	2 GAL.	CONT.
GRASSES	CODE	QTY	BOTANICAL NAME	COMMON NAME	SIZE	CONTAINER
PV	20		PANICUM VIRGATUM 'SHENANDOAH'	SHENANDOAH SWITCH GRASS	2 GAL.	CONT.
PA	9		PENNISETUM ALOPECUROIDES 'HAMELN'	HAMELN FOUNTAIN GRASS	2 GAL.	CONT.
GROUND COVERS	CODE	QTY	BOTANICAL NAME	COMMON NAME	SIZE	CONTAINER
JH	22		JUNIPERUS HORIZONTALIS 'BLUE CHIP'	BLUE CHIP CREEPING JUNIPER	24"-36" SPD.	CONT.

- NOTES:**
- 1) ALL SUBSTITUTIONS MUST RECEIVE APPROVAL FROM THE LANDSCAPE ARCHITECT PRIOR TO DELIVERY TO SITE.
 - 2) PROVIDE AND INSTALL ALL PLANTS SHOWN ON THE PLANTING PLAN DRAWINGS; THE QUANTITIES IN THE PLANT LIST ARE PROVIDED FOR THE CONTRACTOR'S CONVENIENCE ONLY. IF DISCREPANCIES OCCUR, THE LARGER QUANTITY SHALL APPLY.
 - 3) IF THERE IS A DISCREPANCY BETWEEN BOTANICAL AND COMMON NAME, BOTANICAL NAME PREVAILS.

LEGEND

-  PROVIDE AND INSTALL LAWN SEED MIX
-  EXISTING TREE TO REMAIN

SEE SHEET LL-2 FOR LANDSCAPE NOTES AND DETAILS

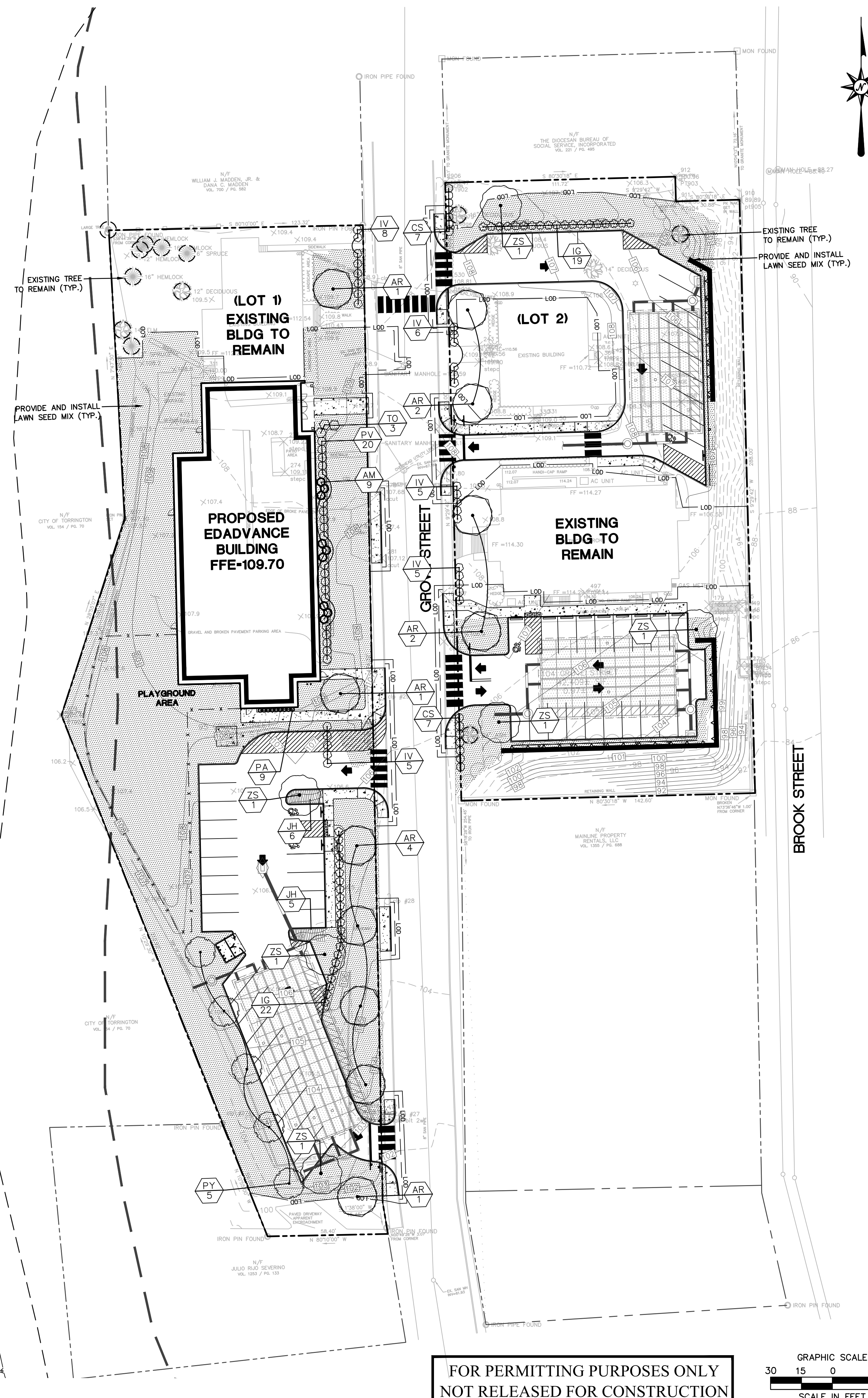

**FOR PERMITTING PURPOSES ONLY
NOT RELEASED FOR CONSTRUCTION**

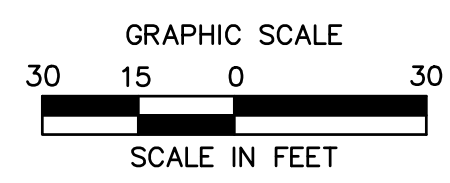

Architecture
 Engineering
 Environmental
 Land Surveying
BL Companies
 355 Research Parkway
 Meriden, CT 06450
 (203) 630-1406

STATE OF CONNECTICUT
 2007
 No. 3999
 LICENSED PROFESSIONAL ENGINEER

PROPOSED EDADVANCE BUILDING
 95-104 GROVE STREET
 TORRINGTON, CONNECTICUT

REVISIONS	Desc.
No.	Date
Designed	X.X.X.
Drawn	X.X.X.
Reviewed	J.J.S.
Scale	1"=30'
Project No.	2202472
Date	03/10/2023
CAD File:	LL220247201
Title	LANDSCAPE PLAN
Sheet No.	LL-1

3/10/2023, CHIEF ARCHITECT, CIVIL ENGINEER, LANDSCAPE ARCHITECT, SURVEYOR, PLANNING, DESIGN, CONSTRUCTION, MANAGEMENT, CONSULTING, INC. THESE DRAWINGS SHALL NOT BE UTILIZED BY ANY PERSON, FIRM OR CORPORATION WITHOUT THE SPECIFIC WRITTEN PERMISSION OF BL COMPANIES.

SITE WORK GENERAL NOTES

- 1. THESE PLANS ARE FOR PERMITTING PURPOSES ONLY AND ARE NOT FOR CONSTRUCTION.
2. ALL CONSTRUCTION SHALL COMPLY WITH THE PROJECT SPECIFICATION MANUAL, MUNICIPAL STANDARDS AND SPECIFICATIONS, CT DEPARTMENT OF TRANSPORTATION STANDARDS AND SPECIFICATIONS, AND STATE BUILDING CODE IN THE ABOVE REFERENCED INCREASING HIERARCHY.
3. REFER TO OTHER PLANS BY OTHER DISCIPLINES, DETAILS AND PROJECT MANUAL FOR ADDITIONAL INFORMATION.
4. DO NOT INTERRUPT EXISTING UTILITIES SERVING FACILITIES OCCUPIED AND USED BY THE OWNER OR OTHERS DURING OCCUPED HOURS EXCEPT WHEN SUCH INTERRUPTIONS HAVE BEEN AUTHORIZED IN WRITING BY THE OWNER AND THE LOCAL MUNICIPALITIES.
5. THE CONTRACTOR SHALL ABIDE BY ALL OSHA, FEDERAL, STATE, AND LOCAL REGULATIONS WHEN OPERATING CRANES, BOOMS, HOISTS, ETC. IN CLOSE PROXIMITY TO OVERHEAD ELECTRIC LINES.
6. THE CONTRACTOR SHALL PROVIDE AS-BUILT RECORD DRAWINGS OF ALL CONSTRUCTION (INCLUDING UNDERGROUND UTILITIES AND STORMWATER SYSTEM) TO THE OWNER AT THE END OF CONSTRUCTION.
7. THE ARCHITECT OR ENGINEER IS NOT RESPONSIBLE FOR SITE SAFETY MEASURES TO BE EMPLOYED DURING CONSTRUCTION.
8. THE CONTRACTOR SHALL COMPLY WITH CFR 29 PART 1926 FOR EXCAVATION, TRENCHING, AND TRENCH PROTECTION REQUIREMENTS.
9. INFORMATION ON EXISTING UTILITIES AND STORM DRAINAGE SYSTEMS HAS BEEN COMPILED FROM AVAILABLE INFORMATION INCLUDING UTILITY COMPANY AND MUNICIPAL OR COUNTY OR STATE RECORD MAPS AND/OR FIELD SURVEY AND IS NOT GUARANTEED CORRECT OR COMPLETE.
10. DO NOT SCALE DRAWINGS. DIMENSIONS GOVERN OVER SCALED DIMENSIONS.
11. SHOULD CONFLICTING INFORMATION BE FOUND WITHIN THE CONTRACT DOCUMENTS, IT IS INCUMBENT UPON THE CONTRACTOR TO REQUEST CLARIFICATION PRIOR TO PROCEEDING WITH THE WORK.
12. ALL CONTRACTORS AND SUBCONTRACTORS SHALL OBTAIN COMPLETE DRAWING PLAN SETS FOR BIDDING AND CONSTRUCTION.
13. ALL NOTES AND DIMENSION DESIGNATED AS "TYPICAL" OR "TYP" APPLY TO ALL LIKE OR SIMILAR CONDITIONS THROUGHOUT THE PROJECT.
14. CONTRACTOR(S) TO TAKE AND VERIFY ALL DIMENSIONS AND CONDITIONS OF THE WORK AND BE RESPONSIBLE FOR COORDINATION OF SAME.
15. BL COMPANIES WILL PREPARE FINAL CONSTRUCTION DOCUMENTS SUITABLE FOR BIDDING AND CONSTRUCTION.
16. NO CONSTRUCTION OR DEMOLITION SHALL BEGIN UNTIL APPROVAL OF THE FINAL PLANS IS GRANTED BY ALL GOVERNING AND REGULATORY AGENCIES.
17. THE DEVELOPER IS RESPONSIBLE FOR OBTAINING ALL NECESSARY ZONING PERMITS REQUIRED BY GOVERNMENT AGENCIES PRIOR TO CONSTRUCTION.
18. THE CONTRACTOR SHALL SUBMIT SHOP DRAWINGS OF ALL PRODUCTS AND MATERIALS PER PLANS AND SPECIFICATIONS TO THE OWNER AND CIVIL ENGINEER FOR REVIEW AND APPROVAL PRIOR TO FABRICATION OR DELIVERY TO THE SITE.
19. THE CONTRACTOR SHALL FOLLOW THE SEQUENCE OF CONSTRUCTION NOTES PROVIDED ON THE SEDIMENT AND EROSION CONTROL PLAN.
20. THE CONTRACTOR SHALL REFERENCE ARCHITECTURAL PLANS FOR EXACT DIMENSIONS AND CONSTRUCTION DETAILS OF BUILDING, AND THE RAISED CONCRETE SIDEWALKS, LANDINGS, RAMPS, AND STAIRS.
21. SHOULD ANY UNCHARTED OR INCORRECTLY CHARTED, EXISTING PIPING OR OTHER UTILITY BE UNCOVERED DURING EXCAVATION, CONSULT THE CIVIL ENGINEER IMMEDIATELY FOR DIRECTIONS BEFORE PROCEEDING FURTHER WITH WORK IN THIS AREA.
22. ALL SITE DIMENSIONS ARE REFERENCED TO THE FACE OF CURBS OR EDGE OF PAVING AS APPLICABLE UNLESS OTHERWISE NOTED.
23. THE CONTRACTOR SHALL PROVIDE AND MAINTAIN TRAFFIC DEVICES FOR PROTECTION OF VEHICLES AND PEDESTRIANS CONSISTING OF DRUMS, BARRIERS, SIGNS, LIGHTS, FENCES, TEMPORARY WALKWAYS, TRAFFIC CONTROLLERS AND UNIFORMED TRAFFIC OFFICERS AS REQUIRED OR AS ORDERED BY THE ENGINEER OR AS REQUIRED BY THE LOCAL GOVERNING AUTHORITIES OR AS REQUIRED BY PERMIT STIPULATIONS OR AS REQUIRED BY THE OWNER.
24. TRAFFIC CONTROL SIGNAGE SHALL CONFORM TO THE STATE DOT STANDARD DETAIL SHEETS AND THE MANUAL OF UNIFORM TRAFFIC CONTROL DEVICES.
25. REFER TO DETAIL SHEETS FOR PAVEMENT, CURBING, AND SIDEWALK INFORMATION.
26. THE CONTRACT LIMIT IS THE PROPERTY LINE UNLESS OTHERWISE SPECIFIED OR SHOWN ON THE CONTRACT DRAWINGS.
27. THE CONTRACTOR SHALL SUBMIT A SHOP DRAWING OF THE PAVEMENT MARKING PAINT MIXTURE PRIOR TO STRIPING.
28. PAVEMENT MARKING KEY:
4" SYDL 4" SOLID YELLOW DOUBLE LINE
4" SYL 4" SOLID YELLOW LINE
4" SWL 4" SOLID WHITE LINE
12" SWB 12" SOLID WHITE STOP BAR
4" BWL 4" BROKEN WHITE LINE 10' STRIPE 30' SPACE
29. PARKING SPACES SHALL BE STRIPED WITH 4" SWL; HATCHED AREA SHALL BE STRIPED WITH 4" SWL AT A 45° ANGLE, 2' ON CENTER.
30. ALL PAVEMENT MARKINGS SHALL HAVE TWO COATS OF PAVEMENT MARKINGS APPLIED TO STRIPING.
31. PAVEMENT MARKINGS SHALL BE HOT APPLIED TYPE IN ACCORDANCE WITH STATE DOT SPECIFICATIONS, UNLESS WHERE EPOXY RESIN PAVEMENT MARKINGS ARE INDICATED.
32. THE CONTRACTOR SHALL RESTORE ANY UTILITY STRUCTURE, DRAINAGE STRUCTURE, PIPE, UTILITY, PAVEMENT, CURBS, SIDEWALKS, LANDSCAPED AREAS, SWALE, PAVEMENT MARKINGS, OR SIGNAGE DISTURBED DURING DEMOLITION AND/OR CONSTRUCTION TO THEIR ORIGINAL CONDITION OR BETTER, AS APPROVED BY THE CIVIL ENGINEER, AND TO THE SATISFACTION OF THE OWNER AND MUNICIPALITY.
33. EXISTING BOUNDARY AND TOPOGRAPHY IS BASED ON DRAWING TITLED "PROPERTY SURVEY PREPARED FOR EDADVANCE - 95 & 104 GROVE STREET - TORRINGTON, CONNECTICUT", SCALE 1"=20', DATED 10/6/2022, BY HRICA ASSOCIATES LLC.
34. ALTERNATIVE METHODS AND PRODUCTS OTHER THAN THOSE SPECIFIED MAY BE USED IF REVIEWED AND APPROVED BY THE OWNER, CIVIL ENGINEER, AND APPROPRIATE REGULATORY AGENCY PRIOR TO INSTALLATION DURING THE BIDDING PROCESS.
35. AN EROSION CONTROL BOND IS REQUIRED TO BE POSTED BY THE CONTRACTOR BEFORE THE START OF ANY ACTIVITY ON OR OFF SITE.
36. THE AMOUNT OF THE EROSION CONTROL BOND WILL BE DETERMINED BY THE AUTHORITY HAVING JURISDICTION.
37. A DEMOLITION PERMIT IS REQUIRED FOR EXISTING BUILDINGS.
38. THE SITE IS CURRENTLY SERVICED BY PUBLIC WATER.
39. NO PART OF THE PROJECT PARCEL IS LOCATED WITHIN ANY FEMA DESIGNATED FLOOD HAZARD AREAS.
40. THERE ARE NO WETLANDS LOCATED ON THE SITE AS INDICATED BY CITY OF TORRINGTON MAPPING.
41. THERE ARE NO WETLANDS LOCATED ON THE SITE AS INDICATED BY CITY OF TORRINGTON MAPPING.
42. 12" SWSB (STOP BAR) AND 4" SYDL AND SWL PAVEMENT MARKINGS LOCATED IN DRIVEWAYS AND IN STATE HIGHWAY SHALL BE EPOXY RESIN TYPE ACCORDING TO CONDOT SPECIFICATIONS.
43. FIRE LANES SHALL BE ESTABLISHED AND PROPERLY DESIGNATED IN ACCORDANCE WITH THE REQUIREMENTS OF THE FIRE DISTRICT FIRE MARSHAL.
44. THE CONTRACTOR SHALL REMOVE CONFLICTING PAVEMENT MARKINGS IN THE ROADWAY BY METHOD APPROVED BY THE AUTHORITY HAVING JURISDICTION OR DOT AS APPLICABLE FOR THE LOCATION OF THE WORK.
45. ALL ADA DESIGNATED PARKING STALLS, ACCESS AISLES AND PEDESTRIAN WALKWAYS SHALL CONFORM TO THE CURRENT VERSION OF THE AMERICANS WITH DISABILITIES ACT STANDARDS FOR ACCESSIBLE DESIGN AND ANSI STANDARDS AND AS MAY BE SUPERCEDED BY THE STATE BUILDING CODE.
46. CONSTRUCTION OCCURRING ON THIS SITE SHALL COMPLY WITH NFPA 241 STANDARD FOR SAFEGUARDING CONSTRUCTION, ALTERATION AND DEMOLITION OPERATIONS, AND CHAPTER 16 OF NFPA 1 UNIFORM FIRE CODE.
47. ALL BUILDINGS, INCLUDING FOUNDATION WALLS AND FOOTINGS AND BASEMENT SLABS INSTALLED ON THE DEMOLITION PLAN ARE TO BE REMOVED FROM THE SITE.
48. SEDIMENT AND EROSION CONTROLS AS SHOWN ON THE SEDIMENT AND EROSION CONTROL PLAN AND/OR DEMOLITION PLAN SHALL BE INSTALLED BY THE DEMOLITION CONTRACTOR PRIOR TO START OF DEMOLITION AND CLEARING AND GRUBBING OPERATIONS.
49. REMOVE AND DISPOSE OF ANY SIDEWALKS, FENCES, STAIRS, WALLS, DEBRIS AND RUBBISH REQUIRING REMOVAL FROM THE WORK AREA IN AN APPROVED OFF SITE LANDFILL, BY AN APPROVED HAULER.
50. THE CONTRACTOR SHALL SECURE ALL PERMITS FOR HIS DEMOLITION AND DISPOSAL OF HIS DEMOLITION MATERIAL TO BE REMOVED FROM THE SITE.
51. ASBESTOS OR HAZARDOUS MATERIAL, IF FOUND ON SITE, SHALL BE REMOVED BY A LICENSED HAZARDOUS MATERIAL ABATEMENT CONTRACTOR.
52. THE CONTRACTOR SHALL PREPARE ALL MANIFEST DOCUMENTS AS REQUIRED PRIOR TO COMMENCEMENT OF DEMOLITION.
53. THE CONTRACTOR SHALL CUT AND PLUG, OR ARRANGE FOR THE APPROPRIATE UTILITY PROVIDER TO CUT AND PLUG ALL SERVICE PIPING AT THE STREET LINE OR AT THE MAIN, AS REQUIRED BY THE UTILITY PROVIDER, OR AS OTHERWISE NOTED OR SHOWN ON THE CONTRACT DRAWINGS.
54. THE CONTRACTOR SHALL PROTECT ALL IRON PINS, MONUMENTS AND PROPERTY CORNERS DURING DEMOLITION AND CONSTRUCTION ACTIVITIES.
55. THE DEMOLITION CONTRACTOR SHALL STABILIZE THE SITE AND KEEP EROSION CONTROL MEASURES IN PLACE UNTIL THE COMPLETION OF HIS WORK OR UNTIL THE COMMENCEMENT OF WORK BY THE SITE CONTRACTOR, WHICHEVER OCCURS FIRST, AS REQUIRED OR DEEMED NECESSARY BY THE ENGINEER OR OWNER'S REPRESENTATIVE.
56. THE DEMOLITION CONTRACTOR SHALL STABILIZE THE SITE AND KEEP EROSION CONTROL MEASURES IN PLACE UNTIL THE COMPLETION OF HIS WORK OR UNTIL THE COMMENCEMENT OF WORK BY THE SITE CONTRACTOR, WHICHEVER OCCURS FIRST, AS REQUIRED OR DEEMED NECESSARY BY THE ENGINEER OR OWNER'S REPRESENTATIVE.
57. IF IMPACTED OR CONTAMINATED SOIL IS ENCOUNTERED BY THE CONTRACTOR, THE CONTRACTOR SHALL SUSPEND EXCAVATION WORK OF IMPACTED SOIL AND NOTIFY THE OWNER AND/OR OWNER'S ENVIRONMENTAL CONSULTANT PRIOR TO PROCEEDING WITH FURTHER WORK IN THE IMPACTED SOIL LOCATION UNTIL FURTHER INSTRUCTED BY THE OWNER AND/OR OWNER'S ENVIRONMENTAL CONSULTANT.
58. EXISTING WATER SERVICES SHALL BE DISCONNECTED AND CAPPED AT MAIN IN ACCORDANCE WITH THE REQUIREMENTS OF THE WATER UTILITY PROVIDER.
59. EXISTING SANITARY LATERAL SHALL BE PLUGGED WITH NON-SHRINK GROUT AT CURB LINE OR AT MAIN CONNECTION IN ACCORDANCE WITH THE SANITARY UTILITY PROVIDER REQUIREMENTS.
60. DOMESTIC GAS SERVICES SHALL BE CAPPED AND SERVICE LINES PURGED OF RESIDUAL GAS IN ACCORDANCE WITH THE GAS UTILITY PROVIDER REQUIREMENTS.
61. THE CONTRACTOR SHALL PROVIDE DISCONNECT NOTIFICATION TO THE MUNICIPALITY ENGINEERING DEPARTMENT, TELECOMMUNICATIONS UTILITY PROVIDER, GAS UTILITY PROVIDER, ELECTRIC UTILITY PROVIDER, SANITARY UTILITY PROVIDER, AND WATER UTILITY PROVIDER AT LEAST THREE WEEKS PRIOR TO BEGINNING DEMOLITION.
62. THE CONTRACTOR IS RESPONSIBLE FOR SECURING A DEMOLITION PERMIT FROM THE TORRINGTON BUILDING DEPARTMENT AND MUST FURNISH THE REQUIRED APPLICATION MATERIAL AND PAY ALL FEES.
63. BACK FILL DEPRESSIONS, FOUNDATION HOLES AND REMOVED DRIVEWAY AREAS IN LOCATIONS NOT SUBJECT TO FURTHER EXCAVATION WITH SOIL MATERIAL APPROVED BY THE OWNER'S GEOTECHNICAL ENGINEER AND COMPACT, FERTILIZE, SEED AND MULCH DISTURBED AREAS NOT SUBJECT TO FURTHER SITE CONSTRUCTION.
64. THE CONTRACTOR SHALL REPAIR PAVEMENTS BY INSTALLING TEMPORARY AND PERMANENT PAVEMENTS IN PUBLIC RIGHTS OF WAYS AS REQUIRED BY LOCAL GOVERNING AUTHORITIES AND THE MUNICIPALITY AND PER PERMIT REQUIREMENTS DUE TO DEMOLITION AND PIPE REMOVAL ACTIVITIES.
65. THE CONTRACTOR SHALL CUT AND REMOVE AT LUMINAIRE AND SIGN LOCATIONS ANY PROTRUDING CONDUITS TO 24" BELOW GRADE.
66. NO WORK ON THIS SITE SHALL BE INITIATED BY THE CONTRACTOR UNTIL A PRE-CONSTRUCTION MEETING WITH OWNER AND THE CIVIL ENGINEER IS PERFORMED.
67. THE CONTRACTOR SHALL ARRANGE FOR AND INSTALL TEMPORARY OR PERMANENT UTILITY CONNECTIONS WHERE INDICATED ON PLAN OR AS REQUIRED.
68. THE CONTRACTOR SHALL NOT COMMENCE DEMOLITION OR UTILITY DISCONNECTIONS UNTIL AUTHORIZED TO DO SO BY THE OWNER.
69. THE CONTRACTOR OR DEMOLITION CONTRACTOR SHALL INSTALL TEMPORARY SHEETING OR SHORING AS NECESSARY TO PROTECT EXISTING AND NEW BUILDINGS, STRUCTURES AND UTILITIES DURING CONSTRUCTION AND DEMOLITION.
70. NO SALVAGE SHALL BE PERMITTED UNLESS PAID TO THE OWNER AS A CREDIT.
71. ANY EXISTING POTABLE WELL AND ANY EXISTING SEPTIC TANKS/ABSORPTION AREAS SHALL BE ABANDONED AND REMOVED PER THE CTDPH AND HEALTH CODE REQUIREMENTS.
72. THE EXISTING BUILDING AND PARKING AREA AND DRIVEWAYS SHALL REMAIN OPEN FOR NORMAL BUSINESS OPERATIONS UNTIL COMPLETION AND OCCUPATION OF THE NEW BUILDING.
73. THE CONTRACTOR SHALL PRESERVE EXISTING VEGETATION WHERE POSSIBLE AND/OR AS NOTED ON DRAWINGS.
74. TOPSOIL SHALL BE STRIPPED AND STOCKPILED ON SITE FOR USE IN FINAL LANDSCAPING.
75. THE CONTRACTOR SHALL COMPACT FILL IN LIFT THICKNESS PER THE GEOTECHNICAL REPORT UNDER ALL PARKING, BUILDING, DRIVE, AND STRUCTURE AREAS TO 95% OF THE MAXIMUM DRY DENSITY AS DETERMINED BY ASTM D1557 (MODIFIED PROCTOR TEST), OR AS REQUIRED BY THE GEOTECHNICAL ENGINEER.
76. UNDERDRAINS SHALL BE ADDED, IF DETERMINED NECESSARY IN THE FIELD BY THE OWNER/GEOTECHNICAL ENGINEER, AFTER SUBGRADE IS ROUGH GRADED.
77. VERTICAL DATUM IS AN ASSUMED DATUM BY HRICA ASSOCIATES, SURVEYOR OF RECORD.
78. CLEARING LIMITS SHALL BE PHYSICALLY MARKED IN THE FIELD AND APPROVED BY THE CITY OF TORRINGTON AGENT PRIOR TO THE START OF WORK ON THE SITE.
79. PROPER CONSTRUCTION PROCEDURES SHALL BE FOLLOWED ON ALL IMPROVEMENTS WITHIN THIS PARCEL SO AS TO PREVENT THE SILTING OF ANY WATERCOURSE OR WETLANDS IN ACCORDANCE WITH THE REGULATIONS OF THE CT DEEP AND THE 2002 CONNECTICUT GUIDELINES FOR SOIL EROSION AND SEDIMENT CONTROL, LATEST EDITION.
80. ALL SITE WORK, MATERIALS OF CONSTRUCTION, AND CONSTRUCTION METHODS FOR EARTHWORK AND STORM DRAINAGE WORK SHALL CONFORM TO THE SPECIFICATIONS AND DETAILS AND APPLICABLE SECTIONS OF THE PROJECT SPECIFICATIONS MANUAL.
81. ALL DISTURBANCE INCURRED TO MUNICIPAL AND STATE PROPERTY DUE TO CONSTRUCTION SHALL BE RESTORED TO ITS PREVIOUS CONDITION OR BETTER, TO THE SATISFACTION OF THE MUNICIPALITY AND STATE AS APPLICABLE FOR THE LOCATION OF THE WORK.
82. ALL CONSTRUCTION WITHIN A DOT RIGHT OF WAY SHALL COMPLY WITH ALL DEPARTMENT OF TRANSPORTATION STANDARDS AND SPECIFICATIONS.
83. THE UTILITY PLAN DETAILS SITE INSTALLED PIPES UP TO 6' FROM THE BUILDING FACE.
84. THE CONTRACTOR SHALL VISIT THE SITE AND VERIFY THE ELEVATION AND LOCATION OF ALL UTILITIES BY VARIOUS MEANS PRIOR TO BEGINNING ANY EXCAVATION.
85. UTILITY CONNECTION DESIGN AS REFLECTED ON THE PLAN MAY CHANGE SUBJECT TO UTILITY PROVIDER AND GOVERNING AUTHORITY STAFF REVIEW.
86. THE CONTRACTOR SHALL ENSURE THAT ALL UTILITY PROVIDERS AND GOVERNING AUTHORITY STANDARDS FOR MATERIALS AND CONSTRUCTION METHODS ARE MET.
87. THE CONTRACTOR SHALL ARRANGE FOR AND COORDINATE WITH THE RESPECTIVE UTILITY PROVIDERS FOR SERVICE INSTALLATIONS AND CONNECTIONS.
88. ALL EXISTING PAVEMENT WHERE UTILITY PIPING IS TO BE INSTALLED SHALL BE SAW CUT.
89. ALL PIPES SHALL BE LAID ON STRAIGHT ALIGNMENTS AND EVEN GRADES USING A PIPE LASER OR OTHER ACCURATE METHOD.
90. SANITARY LATERAL SHALL MAINTAIN (10' MIN. HORIZONTAL 1.5' VERTICAL MIN.) SEPARATION DISTANCE FROM WATER LINES, OR ADDITIONAL PROTECTION MEASURES WILL BE REQUIRED WHERE PERMITTED, WHICH SHALL INCLUDE CONCRETE ENCASEMENT OF PIPING UNLESS OTHERWISE DIRECTED BY THE UTILITY PROVIDERS AND CIVIL ENGINEER.
91. RELOCATION OF UTILITY PROVIDER FACILITIES SHALL BE DONE IN ACCORDANCE WITH THE REQUIREMENTS OF THE UTILITY PROVIDER.
92. THE CONTRACTOR SHALL COMPACT THE PIPE BACKFILL IN 8" LIFTS ACCORDING TO THE PIPE BEDDING DETAILS.
93. CONTRACTOR TO PROVIDE STEEL SLEEVES AND ANNULAR SPACE SAND FILL FOR UTILITY PIPE AND CONDUIT CONNECTIONS UNDER FOOTINGS.
94. BUILDING UTILITY PENETRATIONS AND LOCATIONS ARE SHOWN FOR THE CONTRACTOR'S INFORMATION AND SHALL BE VERIFIED WITH THE BUILDING MEP, STRUCTURAL, AND ARCHITECTURAL DRAWINGS AND WITH THE OWNER'S CONSTRUCTION MANAGER.
95. ALL UTILITY CONSTRUCTION IS SUBJECT TO INSPECTION FOR APPROVAL PRIOR TO BACKFILLING, IN ACCORDANCE WITH THE APPROPRIATE UTILITY PROVIDER REQUIREMENTS.
96. A ONE-FOOT MINIMUM VERTICAL CLEARANCE BETWEEN WATER, GAS, ELECTRICAL, AND TELEPHONE LINES AND STORM PIPING SHALL BE PROVIDED.
97. GRAVITY SANITARY SEWER PIPING AND PRESSURIZED WATERLINES SHALL BE LOCATED IN SEPARATE TRENCHES AT LEAST 10 FEET APART WHENEVER POSSIBLE.
98. SITE CONTRACTOR SHALL PROVIDE ALL BENDS, FITTINGS, ADAPTERS, ETC., AS REQUIRED FOR PIPE CONNECTIONS TO BUILDING STUB OUTS, INCLUDING ROOF/FOOTING DRAIN CONNECTIONS TO ROOF LEADINGS, AND TO STORM DRAINAGE SYSTEM.
99. MANHOLE RIMS AND CATCH BASIN GRATES SHALL BE SET TO ELEVATIONS SHOWN.
100. SITE CONTRACTOR SHALL COORDINATE INSTALLATION OF CONDUIT AND CABLES FOR SITE LIGHTING WITH THE BUILDING ELECTRICAL CONTRACTOR.
101. CONTRACTOR SHALL COORDINATE INSTALLATION FOR ELECTRICAL SERVICES TO PYLON SIGNS AND SITE LIGHTING WITH THE BUILDING ELECTRICAL CONTRACTOR.
102. THE CONTRACTOR SHALL ARRANGE AND COORDINATE WITH UTILITY PROVIDERS FOR WORK TO BE PERFORMED BY UTILITY PROVIDERS.
103. ELECTRIC, AND TELECOMMUNICATIONS SERVICES SHALL BE INSTALLED UNDERGROUND FROM SERVICE POLE CLP #31.
104. ALL WATER LINES TO HAVE A MINIMUM COVER OF 4.5', ALL LINES SHALL BE BEDDED IN 6" SAND AND INITIALLY BACKFILLED WITH 12" SAND.
105. ALL WATER MAINS, WATER SERVICES AND SANITARY SEWER LATERALS SHALL CONFORM TO THE APPLICABLE WATER UTILITY PROVIDER SPECIFICATIONS, AND TO THE APPLICABLE SANITARY SEWER PROVIDER SPECIFICATIONS, AS WELL AS TO OTHER APPLICABLE INDUSTRY CODES (AWWA) AND PROJECT SPECIFICATIONS FOR POTABLE WATER SYSTEMS, AND FOR SANITARY SEWER SYSTEMS.
106. THE CONTRACTOR SHALL MAINTAIN ALL FLOWS AND UTILITY CONNECTIONS TO EXISTING BUILDINGS WITHOUT INTERRUPTION UNLESS/UNTIL AUTHORIZED TO DISCONNECT BY THE OWNERS, THE CIVIL ENGINEER, UTILITY PROVIDERS AND GOVERNING AUTHORITIES.
107. THE CONTRACTOR MAY SUBSTITUTE MASONRY STRUCTURES FOR PRECAST STRUCTURES IF APPROVED BY THE CIVIL ENGINEER AND ALLOWED BY THE GOVERNING AUTHORITY ENGINEER OR OTHER GOVERNING AUTHORITY.
108. PIPING SHALL BE LAID FROM DOWNGRADE END OF PIPE RUN IN AN UPGRADENT DIRECTION WITH BELL END FACING UPGRADE IN THE DIRECTION OF PIPE LAYING.
111. ALL ROP SHALL CONFORM TO THE REQUIREMENTS OF ASTM C-76; ALL ROP SHALL BE CLASS IV UNLESS OTHERWISE SHOWN.
113. MANHOLE SECTIONS AND CONSTRUCTION SHALL CONFORM TO ASTM C-478.
114. HIGH DENSITY POLYETHYLENE (HDPE) STORM SEWER 12" OR GREATER IN DIAMETER SHALL BE HI-0 SURE-LOK 10.8 PIPE AS MANUFACTURED BY HANCOR INC. OR APPROVED EQUAL.
115. HIGH DENSITY POLYETHYLENE (HDPE) STORM SEWER LESS THAN 12" IN DIAMETER SHALL BE HI-0 PIPE AS MANUFACTURED BY HANCOR INC. OR APPROVED EQUAL.
116. COPPER PIPE SHALL BE TYPE K TUBING WITH COMPRESSOR FITTINGS.
118. GAS PIPE MATERIAL SHALL BE PER GAS COMPANY REQUIREMENTS.
119. POLYVINYL CHLORIDE PIPE (PVC) FOR SANITARY PIPING SHALL HAVE BUILT-IN RUBBER GASKET JOINTS.
120. DUCTILE IRON PIPE SHALL CONFORM TO LOCAL JURISDICTION OR AWWA C151 FOR CLASS 52 WITH CEMENT LINING IN ACCORDANCE WITH ANSI A21.4 FOR WATER MAINS AND SERVICES 3" ID AND LARGER.
121. POLYETHYLENE TEREPHTHALATE (PET) SHALL BE USED FOR ALL OTHER TYPES OF RETAINER GLANDS SHALL REQUIRE USE WITH CLASS 53 OR GREATER DUCTILE IRON PIPE.

- 51. ASBESTOS OR HAZARDOUS MATERIAL, IF FOUND ON SITE, SHALL BE REMOVED BY A LICENSED HAZARDOUS MATERIAL ABATEMENT CONTRACTOR.
52. THE CONTRACTOR SHALL PREPARE ALL MANIFEST DOCUMENTS AS REQUIRED PRIOR TO COMMENCEMENT OF DEMOLITION.
53. THE CONTRACTOR SHALL CUT AND PLUG, OR ARRANGE FOR THE APPROPRIATE UTILITY PROVIDER TO CUT AND PLUG ALL SERVICE PIPING AT THE STREET LINE OR AT THE MAIN, AS REQUIRED BY THE UTILITY PROVIDER, OR AS OTHERWISE NOTED OR SHOWN ON THE CONTRACT DRAWINGS.
54. THE CONTRACTOR SHALL PROTECT ALL IRON PINS, MONUMENTS AND PROPERTY CORNERS DURING DEMOLITION AND CONSTRUCTION ACTIVITIES.
55. THE DEMOLITION CONTRACTOR SHALL STABILIZE THE SITE AND KEEP EROSION CONTROL MEASURES IN PLACE UNTIL THE COMPLETION OF HIS WORK OR UNTIL THE COMMENCEMENT OF WORK BY THE SITE CONTRACTOR, WHICHEVER OCCURS FIRST, AS REQUIRED OR DEEMED NECESSARY BY THE ENGINEER OR OWNER'S REPRESENTATIVE.
56. THE DEMOLITION CONTRACTOR SHALL STABILIZE THE SITE AND KEEP EROSION CONTROL MEASURES IN PLACE UNTIL THE COMPLETION OF HIS WORK OR UNTIL THE COMMENCEMENT OF WORK BY THE SITE CONTRACTOR, WHICHEVER OCCURS FIRST, AS REQUIRED OR DEEMED NECESSARY BY THE ENGINEER OR OWNER'S REPRESENTATIVE.
57. IF IMPACTED OR CONTAMINATED SOIL IS ENCOUNTERED BY THE CONTRACTOR, THE CONTRACTOR SHALL SUSPEND EXCAVATION WORK OF IMPACTED SOIL AND NOTIFY THE OWNER AND/OR OWNER'S ENVIRONMENTAL CONSULTANT PRIOR TO PROCEEDING WITH FURTHER WORK IN THE IMPACTED SOIL LOCATION UNTIL FURTHER INSTRUCTED BY THE OWNER AND/OR OWNER'S ENVIRONMENTAL CONSULTANT.
58. EXISTING WATER SERVICES SHALL BE DISCONNECTED AND CAPPED AT MAIN IN ACCORDANCE WITH THE REQUIREMENTS OF THE WATER UTILITY PROVIDER.
59. EXISTING SANITARY LATERAL SHALL BE PLUGGED WITH NON-SHRINK GROUT AT CURB LINE OR AT MAIN CONNECTION IN ACCORDANCE WITH THE SANITARY UTILITY PROVIDER REQUIREMENTS.
60. DOMESTIC GAS SERVICES SHALL BE CAPPED AND SERVICE LINES PURGED OF RESIDUAL GAS IN ACCORDANCE WITH THE GAS UTILITY PROVIDER REQUIREMENTS.
61. THE CONTRACTOR SHALL PROVIDE DISCONNECT NOTIFICATION TO THE MUNICIPALITY ENGINEERING DEPARTMENT, TELECOMMUNICATIONS UTILITY PROVIDER, GAS UTILITY PROVIDER, ELECTRIC UTILITY PROVIDER, SANITARY UTILITY PROVIDER, AND WATER UTILITY PROVIDER AT LEAST THREE WEEKS PRIOR TO BEGINNING DEMOLITION.
62. THE CONTRACTOR IS RESPONSIBLE FOR SECURING A DEMOLITION PERMIT FROM THE TORRINGTON BUILDING DEPARTMENT AND MUST FURNISH THE REQUIRED APPLICATION MATERIAL AND PAY ALL FEES.
63. BACK FILL DEPRESSIONS, FOUNDATION HOLES AND REMOVED DRIVEWAY AREAS IN LOCATIONS NOT SUBJECT TO FURTHER EXCAVATION WITH SOIL MATERIAL APPROVED BY THE OWNER'S GEOTECHNICAL ENGINEER AND COMPACT, FERTILIZE, SEED AND MULCH DISTURBED AREAS NOT SUBJECT TO FURTHER SITE CONSTRUCTION.
64. THE CONTRACTOR SHALL REPAIR PAVEMENTS BY INSTALLING TEMPORARY AND PERMANENT PAVEMENTS IN PUBLIC RIGHTS OF WAYS AS REQUIRED BY LOCAL GOVERNING AUTHORITIES AND THE MUNICIPALITY AND PER PERMIT REQUIREMENTS DUE TO DEMOLITION AND PIPE REMOVAL ACTIVITIES.
65. THE CONTRACTOR SHALL CUT AND REMOVE AT LUMINAIRE AND SIGN LOCATIONS ANY PROTRUDING CONDUITS TO 24" BELOW GRADE.
66. NO WORK ON THIS SITE SHALL BE INITIATED BY THE CONTRACTOR UNTIL A PRE-CONSTRUCTION MEETING WITH OWNER AND THE CIVIL ENGINEER IS PERFORMED.
67. THE CONTRACTOR SHALL ARRANGE FOR AND INSTALL TEMPORARY OR PERMANENT UTILITY CONNECTIONS WHERE INDICATED ON PLAN OR AS REQUIRED.
68. THE CONTRACTOR SHALL NOT COMMENCE DEMOLITION OR UTILITY DISCONNECTIONS UNTIL AUTHORIZED TO DO SO BY THE OWNER.
69. THE CONTRACTOR OR DEMOLITION CONTRACTOR SHALL INSTALL TEMPORARY SHEETING OR SHORING AS NECESSARY TO PROTECT EXISTING AND NEW BUILDINGS, STRUCTURES AND UTILITIES DURING CONSTRUCTION AND DEMOLITION.
70. NO SALVAGE SHALL BE PERMITTED UNLESS PAID TO THE OWNER AS A CREDIT.
71. ANY EXISTING POTABLE WELL AND ANY EXISTING SEPTIC TANKS/ABSORPTION AREAS SHALL BE ABANDONED AND REMOVED PER THE CTDPH AND HEALTH CODE REQUIREMENTS.
72. THE EXISTING BUILDING AND PARKING AREA AND DRIVEWAYS SHALL REMAIN OPEN FOR NORMAL BUSINESS OPERATIONS UNTIL COMPLETION AND OCCUPATION OF THE NEW BUILDING.
73. THE CONTRACTOR SHALL PRESERVE EXISTING VEGETATION WHERE POSSIBLE AND/OR AS NOTED ON DRAWINGS.
74. TOPSOIL SHALL BE STRIPPED AND STOCKPILED ON SITE FOR USE IN FINAL LANDSCAPING.
75. THE CONTRACTOR SHALL COMPACT FILL IN LIFT THICKNESS PER THE GEOTECHNICAL REPORT UNDER ALL PARKING, BUILDING, DRIVE, AND STRUCTURE AREAS TO 95% OF THE MAXIMUM DRY DENSITY AS DETERMINED BY ASTM D1557 (MODIFIED PROCTOR TEST), OR AS REQUIRED BY THE GEOTECHNICAL ENGINEER.
76. UNDERDRAINS SHALL BE ADDED, IF DETERMINED NECESSARY IN THE FIELD BY THE OWNER/GEOTECHNICAL ENGINEER, AFTER SUBGRADE IS ROUGH GRADED.
77. VERTICAL DATUM IS AN ASSUMED DATUM BY HRICA ASSOCIATES, SURVEYOR OF RECORD.
78. CLEARING LIMITS SHALL BE PHYSICALLY MARKED IN THE FIELD AND APPROVED BY THE CITY OF TORRINGTON AGENT PRIOR TO THE START OF WORK ON THE SITE.
79. PROPER CONSTRUCTION PROCEDURES SHALL BE FOLLOWED ON ALL IMPROVEMENTS WITHIN THIS PARCEL SO AS TO PREVENT THE SILTING OF ANY WATERCOURSE OR WETLANDS IN ACCORDANCE WITH THE REGULATIONS OF THE CT DEEP AND THE 2002 CONNECTICUT GUIDELINES FOR SOIL EROSION AND SEDIMENT CONTROL, LATEST EDITION.
80. ALL SITE WORK, MATERIALS OF CONSTRUCTION, AND CONSTRUCTION METHODS FOR EARTHWORK AND STORM DRAINAGE WORK SHALL CONFORM TO THE SPECIFICATIONS AND DETAILS AND APPLICABLE SECTIONS OF THE PROJECT SPECIFICATIONS MANUAL.
81. ALL DISTURBANCE INCURRED TO MUNICIPAL AND STATE PROPERTY DUE TO CONSTRUCTION SHALL BE RESTORED TO ITS PREVIOUS CONDITION OR BETTER, TO THE SATISFACTION OF THE MUNICIPALITY AND STATE AS APPLICABLE FOR THE LOCATION OF THE WORK.
82. ALL CONSTRUCTION WITHIN A DOT RIGHT OF WAY SHALL COMPLY WITH ALL DEPARTMENT OF TRANSPORTATION STANDARDS AND SPECIFICATIONS.
83. THE UTILITY PLAN DETAILS SITE INSTALLED PIPES UP TO 6' FROM THE BUILDING FACE.
84. THE CONTRACTOR SHALL VISIT THE SITE AND VERIFY THE ELEVATION AND LOCATION OF ALL UTILITIES BY VARIOUS MEANS PRIOR TO BEGINNING ANY EXCAVATION.
85. UTILITY CONNECTION DESIGN AS REFLECTED ON THE PLAN MAY CHANGE SUBJECT TO UTILITY PROVIDER AND GOVERNING AUTHORITY STAFF REVIEW.
86. THE CONTRACTOR SHALL ENSURE THAT ALL UTILITY PROVIDERS AND GOVERNING AUTHORITY STANDARDS FOR MATERIALS AND CONSTRUCTION METHODS ARE MET.
87. THE CONTRACTOR SHALL ARRANGE FOR AND COORDINATE WITH THE RESPECTIVE UTILITY PROVIDERS FOR SERVICE INSTALLATIONS AND CONNECTIONS.
88. ALL EXISTING PAVEMENT WHERE UTILITY PIPING IS TO BE INSTALLED SHALL BE SAW CUT.
89. ALL PIPES SHALL BE LAID ON STRAIGHT ALIGNMENTS AND EVEN GRADES USING A PIPE LASER OR OTHER ACCURATE METHOD.
90. SANITARY LATERAL SHALL MAINTAIN (10' MIN. HORIZONTAL 1.5' VERTICAL MIN.) SEPARATION DISTANCE FROM WATER LINES, OR ADDITIONAL PROTECTION MEASURES WILL BE REQUIRED WHERE PERMITTED, WHICH SHALL INCLUDE CONCRETE ENCASEMENT OF PIPING UNLESS OTHERWISE DIRECTED BY THE UTILITY PROVIDERS AND CIVIL ENGINEER.
91. RELOCATION OF UTILITY PROVIDER FACILITIES SHALL BE DONE IN ACCORDANCE WITH THE REQUIREMENTS OF THE UTILITY PROVIDER.
92. THE CONTRACTOR SHALL COMPACT THE PIPE BACKFILL IN 8" LIFTS ACCORDING TO THE PIPE BEDDING DETAILS.
93. CONTRACTOR TO PROVIDE STEEL SLEEVES AND ANNULAR SPACE SAND FILL FOR UTILITY PIPE AND CONDUIT CONNECTIONS UNDER FOOTINGS.
94. BUILDING UTILITY PENETRATIONS AND LOCATIONS ARE SHOWN FOR THE CONTRACTOR'S INFORMATION AND SHALL BE VERIFIED WITH THE BUILDING MEP, STRUCTURAL, AND ARCHITECTURAL DRAWINGS AND WITH THE OWNER'S CONSTRUCTION MANAGER.
95. ALL UTILITY CONSTRUCTION IS SUBJECT TO INSPECTION FOR APPROVAL PRIOR TO BACKFILLING, IN ACCORDANCE WITH THE APPROPRIATE UTILITY PROVIDER REQUIREMENTS.
96. A ONE-FOOT MINIMUM VERTICAL CLEARANCE BETWEEN WATER, GAS, ELECTRICAL, AND TELEPHONE LINES AND STORM PIPING SHALL BE PROVIDED.
97. GRAVITY SANITARY SEWER PIPING AND PRESSURIZED WATERLINES SHALL BE LOCATED IN SEPARATE TRENCHES AT LEAST 10 FEET APART WHENEVER POSSIBLE.
98. SITE CONTRACTOR SHALL PROVIDE ALL BENDS, FITTINGS, ADAPTERS, ETC., AS REQUIRED FOR PIPE CONNECTIONS TO BUILDING STUB OUTS, INCLUDING ROOF/FOOTING DRAIN CONNECTIONS TO ROOF LEADINGS, AND TO STORM DRAINAGE SYSTEM.
99. MANHOLE RIMS AND CATCH BASIN GRATES SHALL BE SET TO ELEVATIONS SHOWN.
100. SITE CONTRACTOR SHALL COORDINATE INSTALLATION OF CONDUIT AND CABLES FOR SITE LIGHTING WITH THE BUILDING ELECTRICAL CONTRACTOR.
101. CONTRACTOR SHALL COORDINATE INSTALLATION FOR ELECTRICAL SERVICES TO PYLON SIGNS AND SITE LIGHTING WITH THE BUILDING ELECTRICAL CONTRACTOR.
102. THE CONTRACTOR SHALL ARRANGE AND COORDINATE WITH UTILITY PROVIDERS FOR WORK TO BE PERFORMED BY UTILITY PROVIDERS.
103. ELECTRIC, AND TELECOMMUNICATIONS SERVICES SHALL BE INSTALLED UNDERGROUND FROM SERVICE POLE CLP #31.
104. ALL WATER LINES TO HAVE A MINIMUM COVER OF 4.5', ALL LINES SHALL BE BEDDED IN 6" SAND AND INITIALLY BACKFILLED WITH 12" SAND.
105. ALL WATER MAINS, WATER SERVICES AND SANITARY SEWER LATERALS SHALL CONFORM TO THE APPLICABLE WATER UTILITY PROVIDER SPECIFICATIONS, AND TO THE APPLICABLE SANITARY SEWER PROVIDER SPECIFICATIONS, AS WELL AS TO OTHER APPLICABLE INDUSTRY CODES (AWWA) AND PROJECT SPECIFICATIONS FOR POTABLE WATER SYSTEMS, AND FOR SANITARY SEWER SYSTEMS.
106. THE CONTRACTOR SHALL MAINTAIN ALL FLOWS AND UTILITY CONNECTIONS TO EXISTING BUILDINGS WITHOUT INTERRUPTION UNLESS/UNTIL AUTHORIZED TO DISCONNECT BY THE OWNERS, THE CIVIL ENGINEER, UTILITY PROVIDERS AND GOVERNING AUTHORITIES.
107. THE CONTRACTOR MAY SUBSTITUTE MASONRY STRUCTURES FOR PRECAST STRUCTURES IF APPROVED BY THE CIVIL ENGINEER AND ALLOWED BY THE GOVERNING AUTHORITY ENGINEER OR OTHER GOVERNING AUTHORITY.
108. PIPING SHALL BE LAID FROM DOWNGRADE END OF PIPE RUN IN AN UPGRADENT DIRECTION WITH BELL END FACING UPGRADE IN THE DIRECTION OF PIPE LAYING.
111. ALL ROP SHALL CONFORM TO THE REQUIREMENTS OF ASTM C-76; ALL ROP SHALL BE CLASS IV UNLESS OTHERWISE SHOWN.
113. MANHOLE SECTIONS AND CONSTRUCTION SHALL CONFORM TO ASTM C-478.
114. HIGH DENSITY POLYETHYLENE (HDPE) STORM SEWER 12" OR GREATER IN DIAMETER SHALL BE HI-0 SURE-LOK 10.8 PIPE AS MANUFACTURED BY HANCOR INC. OR APPROVED EQUAL.
115. HIGH DENSITY POLYETHYLENE (HDPE) STORM SEWER LESS THAN 12" IN DIAMETER SHALL BE HI-0 PIPE AS MANUFACTURED BY HANCOR INC. OR APPROVED EQUAL.
116. COPPER PIPE SHALL BE TYPE K TUBING WITH COMPRESSOR FITTINGS.
118. GAS PIPE MATERIAL SHALL BE PER GAS COMPANY REQUIREMENTS.
119. POLYVINYL CHLORIDE PIPE (PVC) FOR SANITARY PIPING SHALL HAVE BUILT-IN RUBBER GASKET JOINTS.
120. DUCTILE IRON PIPE SHALL CONFORM TO LOCAL JURISDICTION OR AWWA C151 FOR CLASS 52 WITH CEMENT LINING IN ACCORDANCE WITH ANSI A21.4 FOR WATER MAINS AND SERVICES 3" ID AND LARGER.
121. POLYETHYLENE TEREPHTHALATE (PET) SHALL BE USED FOR ALL OTHER TYPES OF RETAINER GLANDS SHALL REQUIRE USE WITH CLASS 53 OR GREATER DUCTILE IRON PIPE.

- 97. GRAVITY SANITARY SEWER PIPING AND PRESSURIZED WATERLINES SHALL BE LOCATED IN SEPARATE TRENCHES AT LEAST 10 FEET APART WHENEVER POSSIBLE.
98. SITE CONTRACTOR SHALL PROVIDE ALL BENDS, FITTINGS, ADAPTERS, ETC., AS REQUIRED FOR PIPE CONNECTIONS TO BUILDING STUB OUTS, INCLUDING ROOF/FOOTING DRAIN CONNECTIONS TO ROOF LEADINGS, AND TO STORM DRAINAGE SYSTEM.
99. MANHOLE RIMS AND CATCH BASIN GRATES SHALL BE SET TO ELEVATIONS SHOWN.
100. SITE CONTRACTOR SHALL COORDINATE INSTALLATION OF CONDUIT AND CABLES FOR SITE LIGHTING WITH THE BUILDING ELECTRICAL CONTRACTOR.
101. CONTRACTOR SHALL COORDINATE INSTALLATION FOR ELECTRICAL SERVICES TO PYLON SIGNS AND SITE LIGHTING WITH THE BUILDING ELECTRICAL CONTRACTOR.
102. THE CONTRACTOR SHALL ARRANGE AND COORDINATE WITH UTILITY PROVIDERS FOR WORK TO BE PERFORMED BY UTILITY PROVIDERS.
103. ELECTRIC, AND TELECOMMUNICATIONS SERVICES SHALL BE INSTALLED UNDERGROUND FROM SERVICE POLE CLP #31.
104. ALL WATER LINES TO HAVE A MINIMUM COVER OF 4.5', ALL LINES SHALL BE BEDDED IN 6" SAND AND INITIALLY BACKFILLED WITH 12" SAND.
105. ALL WATER MAINS, WATER SERVICES AND SANITARY SEWER LATERALS SHALL CONFORM TO THE APPLICABLE WATER UTILITY PROVIDER SPECIFICATIONS, AND TO THE APPLICABLE SANITARY SEWER PROVIDER SPECIFICATIONS, AS WELL AS TO OTHER APPLICABLE INDUSTRY CODES (AWWA) AND PROJECT SPECIFICATIONS FOR POTABLE WATER SYSTEMS, AND FOR SANITARY SEWER SYSTEMS.
106. THE CONTRACTOR SHALL MAINTAIN ALL FLOWS AND UTILITY CONNECTIONS TO EXISTING BUILDINGS WITHOUT INTERRUPTION UNLESS/UNTIL AUTHORIZED TO DISCONNECT BY THE OWNERS, THE CIVIL ENGINEER, UTILITY PROVIDERS AND GOVERNING AUTHORITIES.
107. THE CONTRACTOR MAY SUBSTITUTE MASONRY STRUCTURES FOR PRECAST STRUCTURES IF APPROVED BY THE CIVIL ENGINEER AND ALLOWED BY THE GOVERNING AUTHORITY ENGINEER OR OTHER GOVERNING AUTHORITY.
108. PIPING SHALL BE LAID FROM DOWNGRADE END OF PIPE RUN IN AN UPGRADENT DIRECTION WITH BELL END FACING UPGRADE IN THE DIRECTION OF PIPE LAYING.
111. ALL ROP SHALL CONFORM TO THE REQUIREMENTS OF ASTM C-76; ALL ROP SHALL BE CLASS IV UNLESS OTHERWISE SHOWN.
113. MANHOLE SECTIONS AND CONSTRUCTION SHALL CONFORM TO ASTM C-478.
114. HIGH DENSITY POLYETHYLENE (HDPE) STORM SEWER 12" OR GREATER IN DIAMETER SHALL BE HI-0 SURE-LOK 10.8 PIPE AS MANUFACTURED BY HANCOR INC. OR APPROVED EQUAL.
115. HIGH DENSITY POLYETHYLENE (HDPE) STORM SEWER LESS THAN 12" IN DIAMETER SHALL BE HI-0 PIPE AS MANUFACTURED BY HANCOR INC. OR APPROVED EQUAL.
116. COPPER PIPE SHALL BE TYPE K TUBING WITH COMPRESSOR FITTINGS.
118. GAS PIPE MATERIAL SHALL BE PER GAS COMPANY REQUIREMENTS.
119. POLYVINYL CHLORIDE PIPE (PVC) FOR SANITARY PIPING SHALL HAVE BUILT-IN RUBBER GASKET JOINTS.
120. DUCTILE IRON PIPE SHALL CONFORM TO LOCAL JURISDICTION OR AWWA C151 FOR CLASS 52 WITH CEMENT LINING IN ACCORDANCE WITH ANSI A21.4 FOR WATER MAINS AND SERVICES 3" ID AND LARGER.
121. POLYETHYLENE TEREPHTHALATE (PET) SHALL BE USED FOR ALL OTHER TYPES OF RETAINER GLANDS SHALL REQUIRE USE WITH CLASS 53 OR GREATER DUCTILE IRON PIPE.

DEFINITIONS
MUNICIPALITY SHALL MEAN CITY OF TORRINGTON
COUNTY SHALL MEAN LITCHFIELD COUNTY
STATE SHALL MEAN STATE OF CONNECTICUT
WATER UTILITY PROVIDER SHALL MEAN TORRINGTON WATER COMPANY
SANITARY UTILITY PROVIDER SHALL MEAN TORRINGTON WATER POLLUTION CONTROL AUTHORITY
GAS UTILITY PROVIDER SHALL MEAN EVERSOURCE ENERGY - GAS DISTRIBUTION
TELECOMMUNICATIONS UTILITY PROVIDER SHALL MEAN FRONTIER COMMUNICATIONS
ELECTRIC UTILITY PROVIDER SHALL MEAN EVERSOURCE ENERGY - ELECTRIC TRANSMISSION



355 Research Parkway
Meriden, CT 06450
(203) 630-1406



PROPOSED EDADVANCE BUILDING
95-104 GROVE STREET
TORRINGTON, CONNECTICUT

Table with columns: REVISIONS (No., Date, Desc.), Designed (C.J.L.), Drawn (C.J.L.), Reviewed (J.J.S.), Scale (NONE), Project No. (2202472), Date (03/10/2023), CAD File (GN220247201), Title (GENERAL NOTES), Sheet No.

FOR PERMITTING PURPOSES ONLY
NOT RELEASED FOR CONSTRUCTION

GN-1

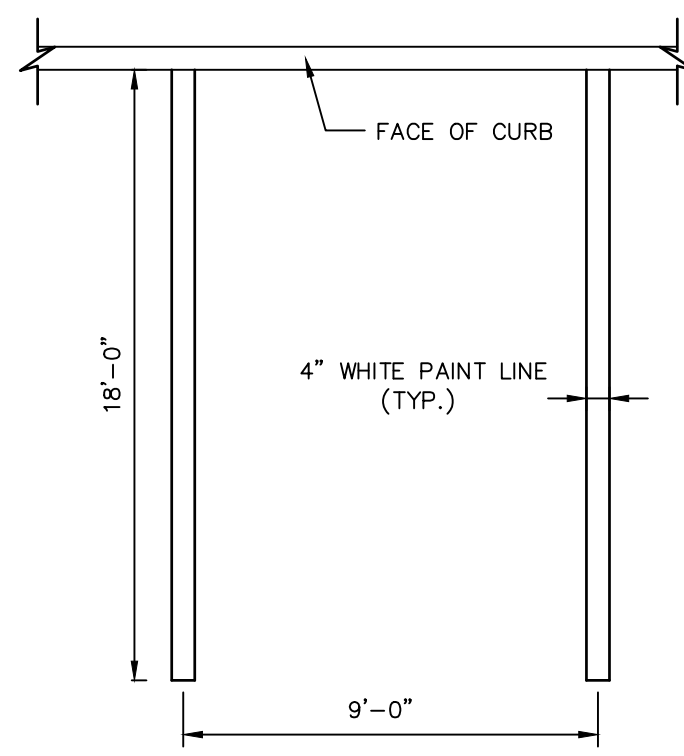

NOTE:
1. PROVIDE 2 COATS OF PAINT ON ALL SURFACES.
2. SEE PLAN FOR ACTUAL SPACE LOCATION AND DIMENSIONS.

TYPICAL PARKING SPACE DETAIL

N.T.S. BLP-003

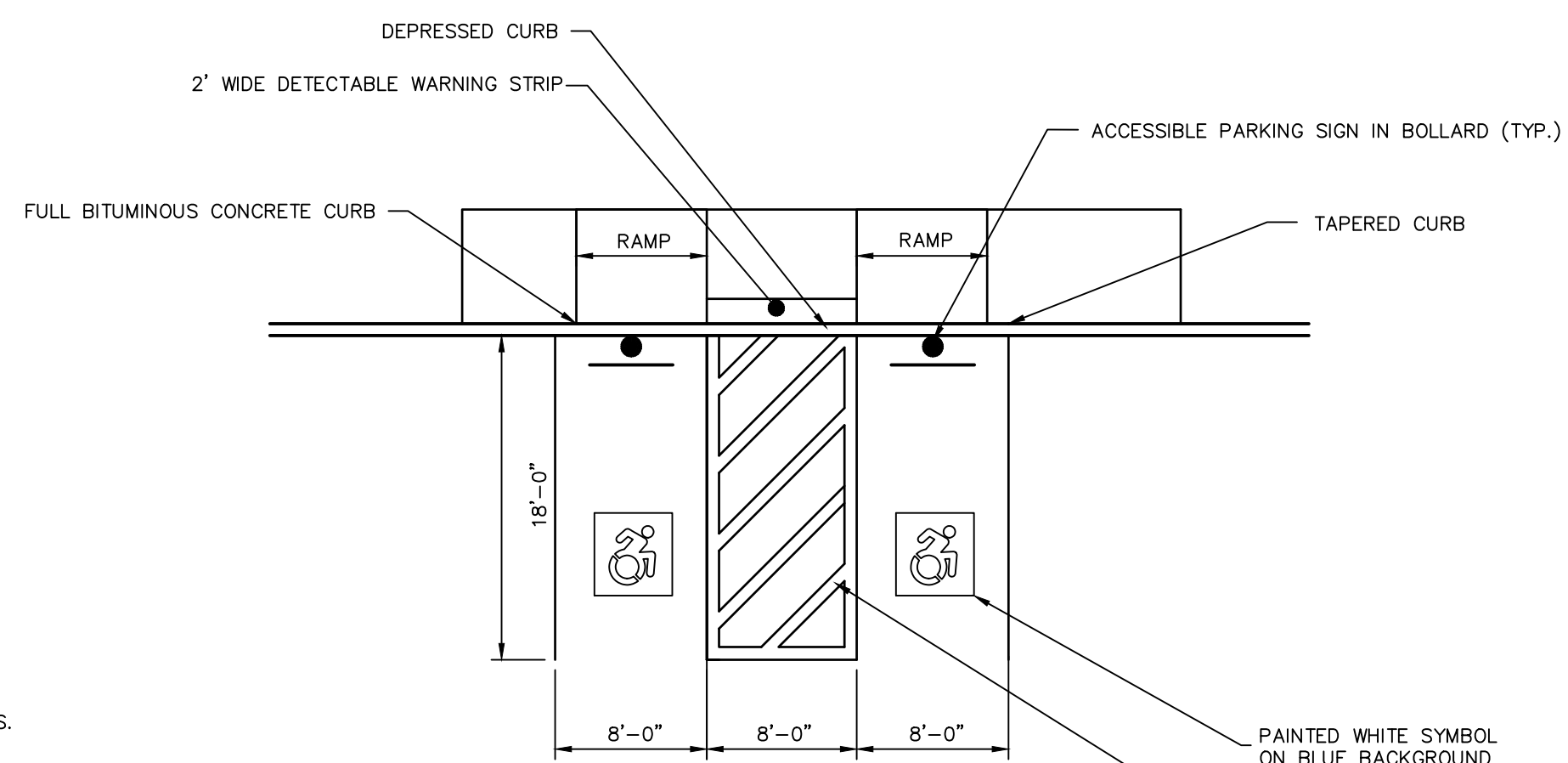

NOTE:
1. SEE SITE PLAN FOR ACCESSIBLE SPACE LOCATIONS.
2. PROVIDE 2 COATS OF PAINT ON ALL SURFACES.

TYPICAL ACCESSIBLE PARKING SPACE AND RAMP DETAIL

N.T.S. BLP-004

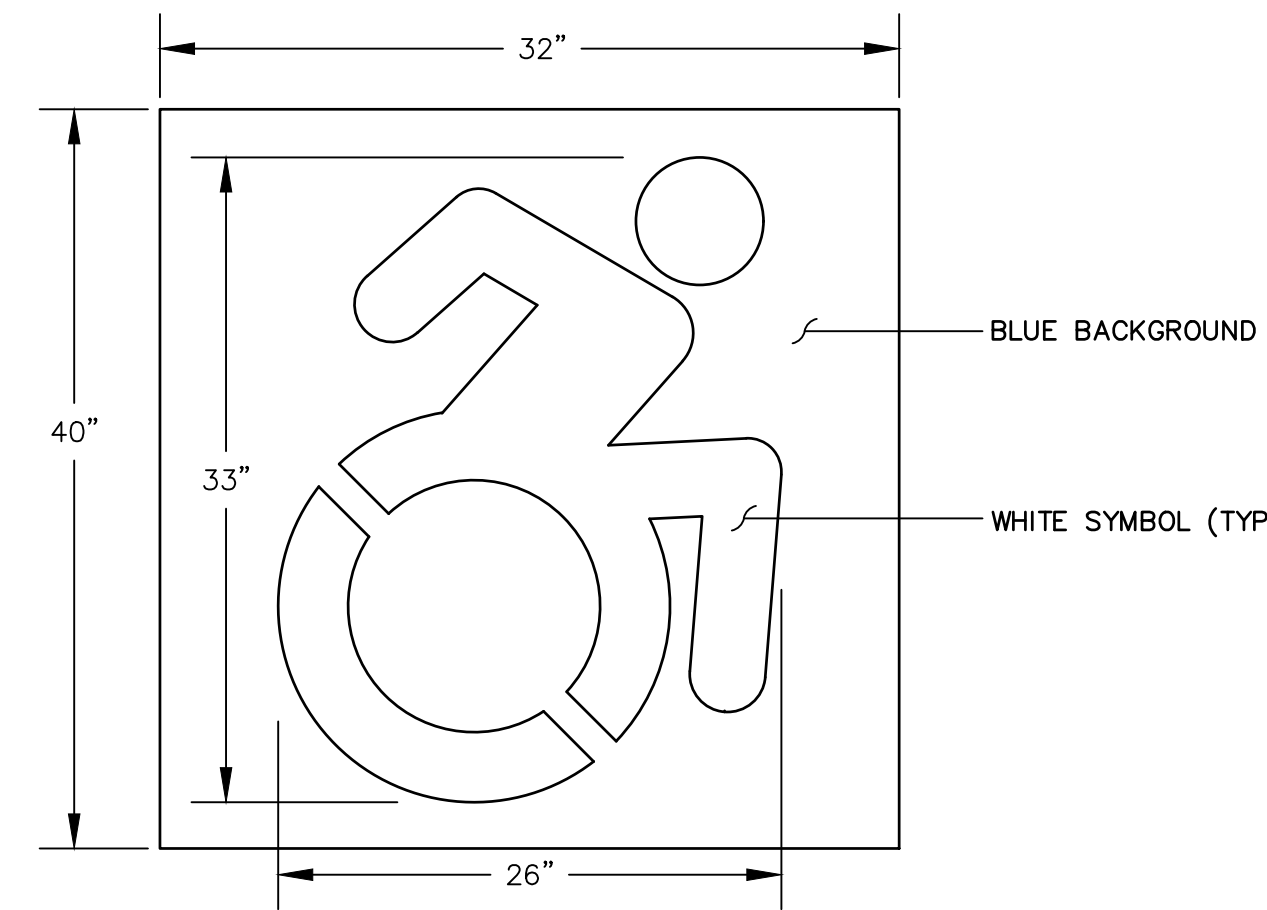

NOTE: HANDICAP SYMBOL TO ADHERE TO STATE BUILDING CODE, LATEST EDITION

CONNECTICUT SYMBOL OF ACCESSIBILITY

N.T.S.

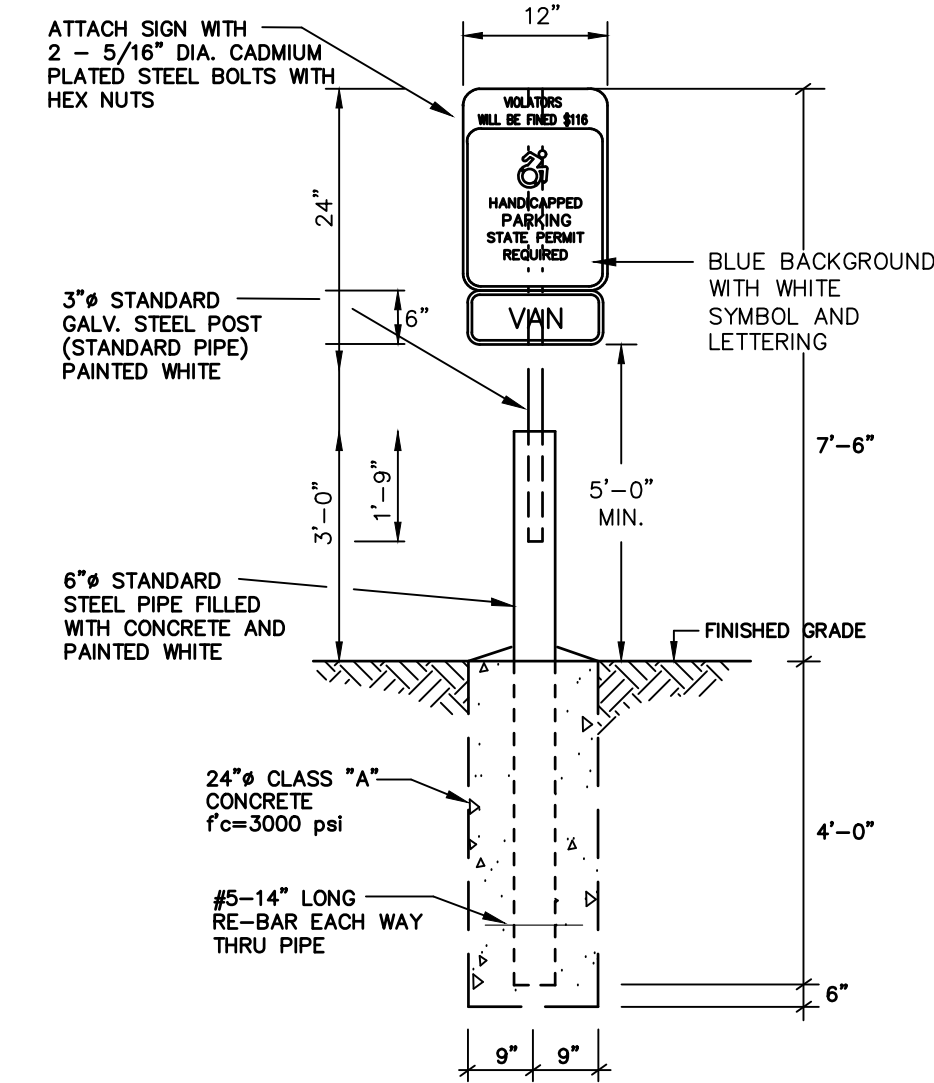

HANDICAP SIGN BOLLARD DETAIL

N.T.S.

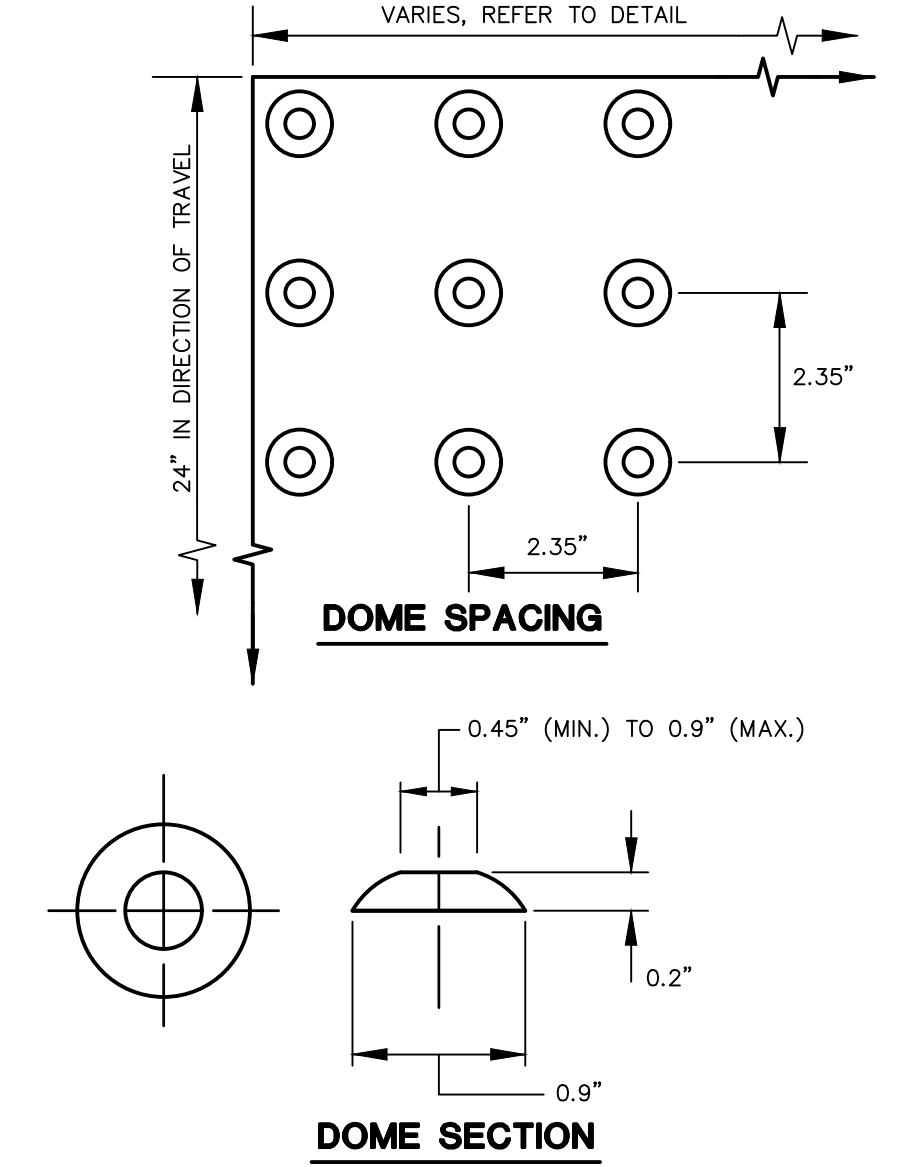

DETECTABLE WARNING

N.T.S.

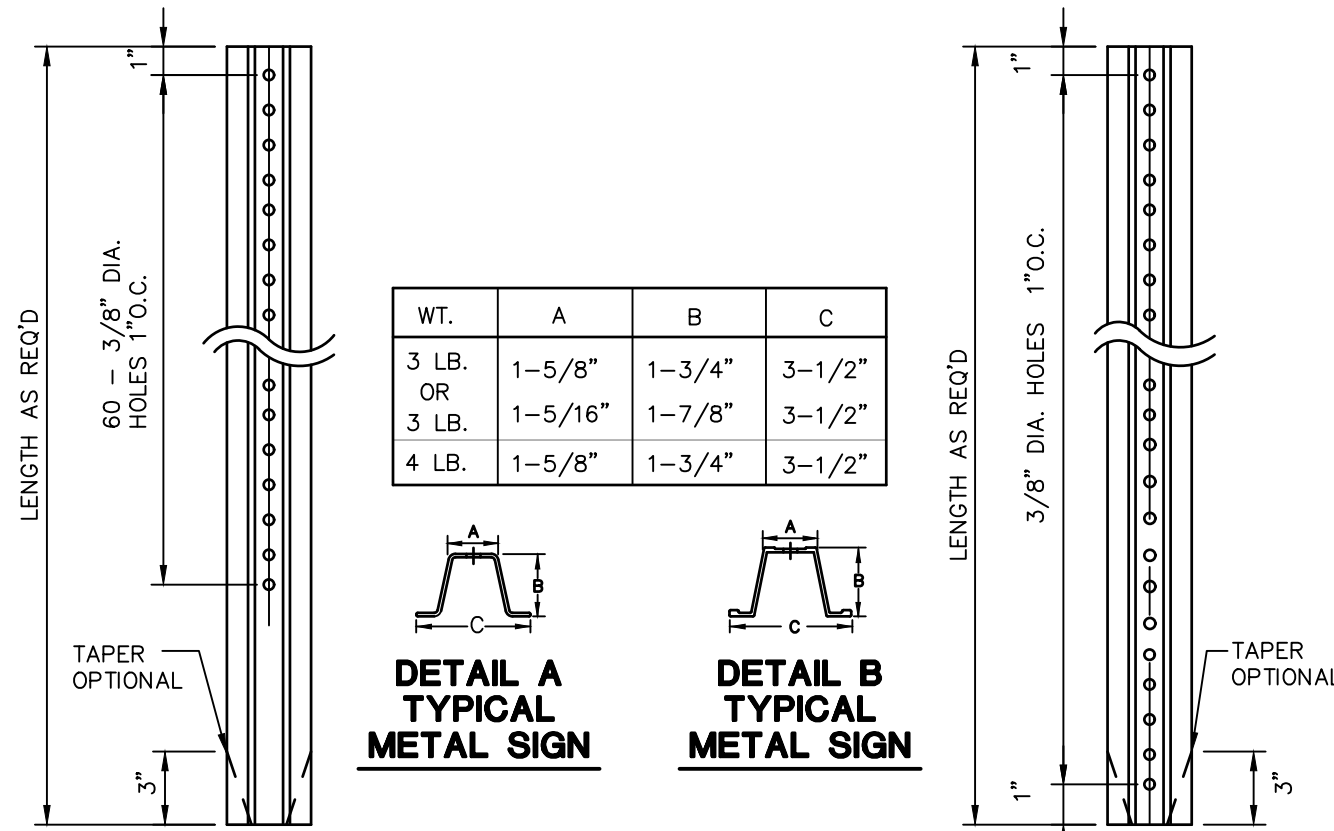

DETAIL A HOLE LOCATION

DETAIL B HOLE LOCATION

NOTE:
STEEL FOR POSTS SHALL CONFORM TO THE MECHANICAL REQUIREMENTS OF ASTM A 499-81 GRADE 60 AND TO THE CHEMICAL REQUIREMENTS OF ASTM A-78 CARBON STEEL, TEE RAIL HAVING NOMINAL HEIGHT OF 70 LBS OR GREATER PER LINEAR YARD.
AFTER FABRICATION ALL STEEL POSTS SHALL BE GALVANIZED TO MEET THE REQUIREMENTS OF ASTM A-123.
SIGN MOUNTING HEIGHT TO BE APPROVED BY THE ENGINEER.

TYPICAL METAL SIGN POSTS

N.T.S. BLS0-001

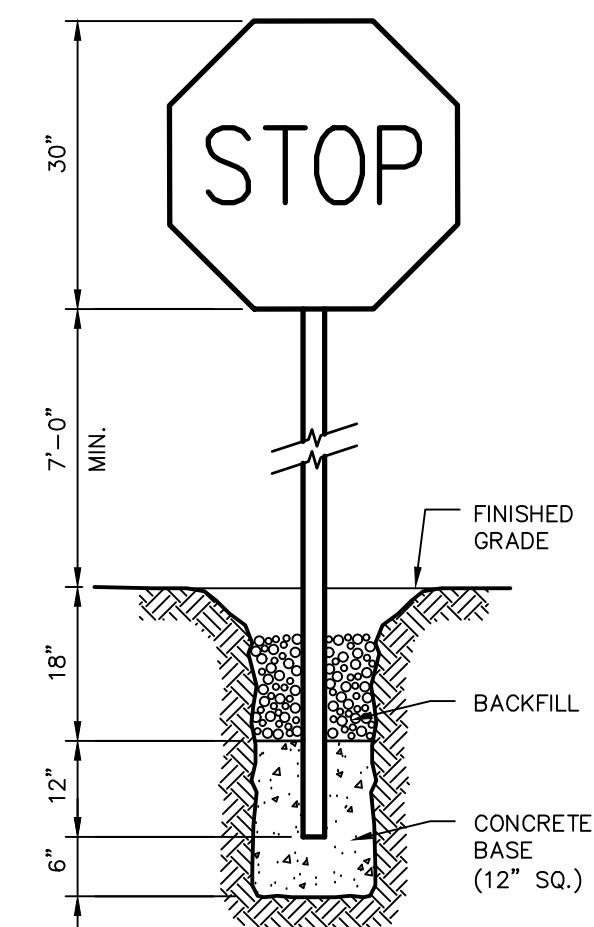

STOP SIGN

N.T.S. BLS0-002

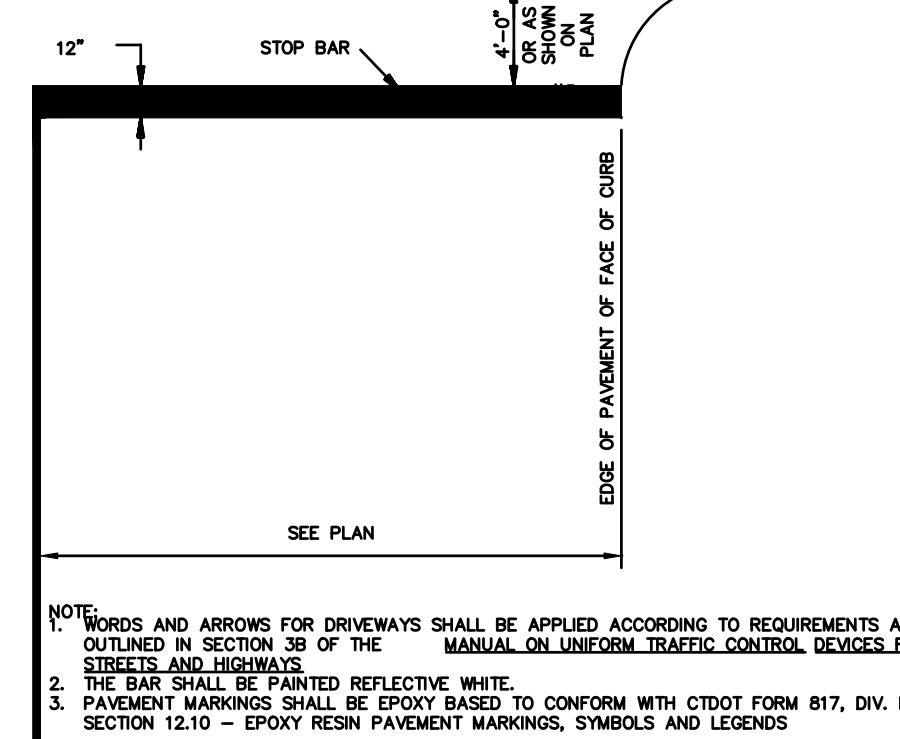

STOP BAR PAVEMENT MARKING

N.T.S.

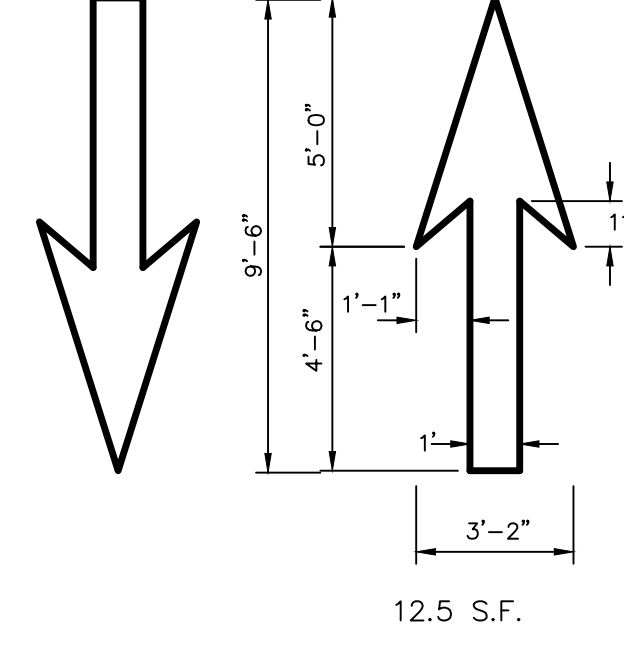

PAVEMENT ARROW DETAILS

N.T.S. BLP-006

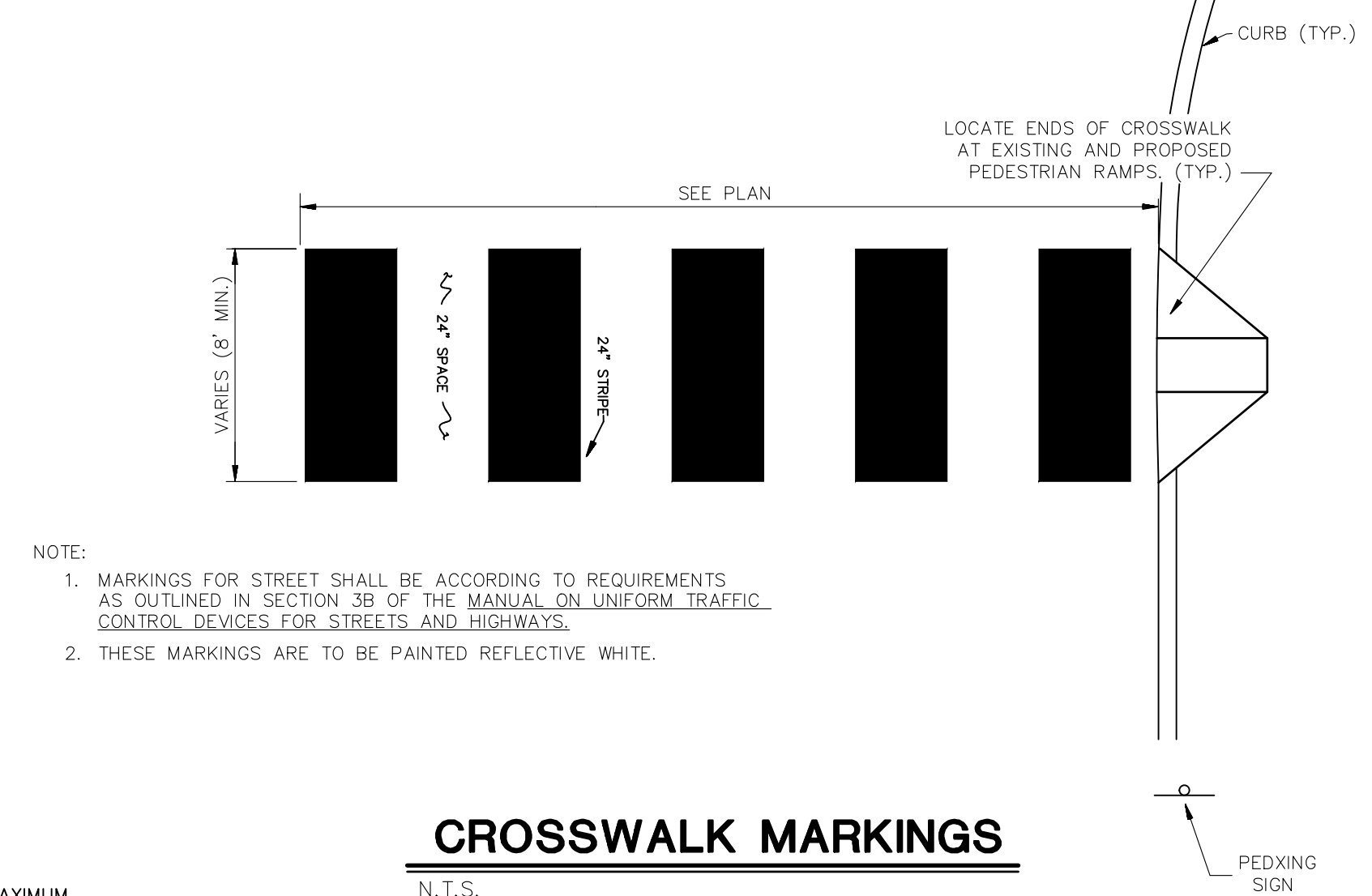

CROSSWALK MARKINGS

N.T.S.

NOTE:
1. MARKINGS FOR STREET SHALL BE ACCORDING TO REQUIREMENTS AS OUTLINED IN SECTION 3B OF THE MANUAL ON UNIFORM TRAFFIC CONTROL DEVICES FOR STREETS AND HIGHWAYS.
2. THESE MARKINGS ARE TO BE PAINTED REFLECTIVE WHITE.

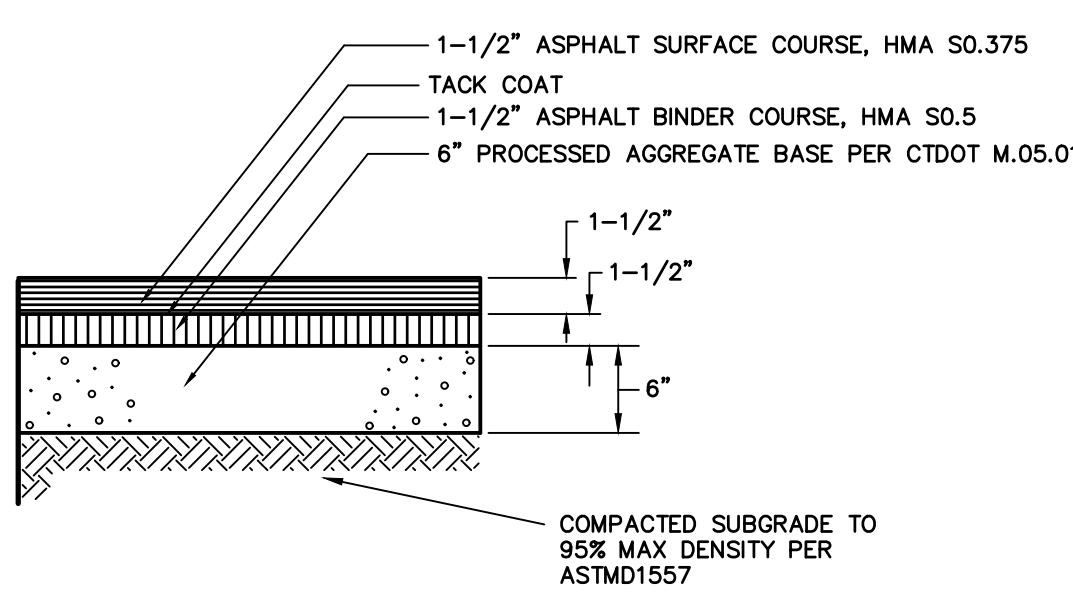

STANDARD DUTY BITUMINOUS CONCRETE PAVEMENT STRUCTURE

N.T.S. ZPC-014

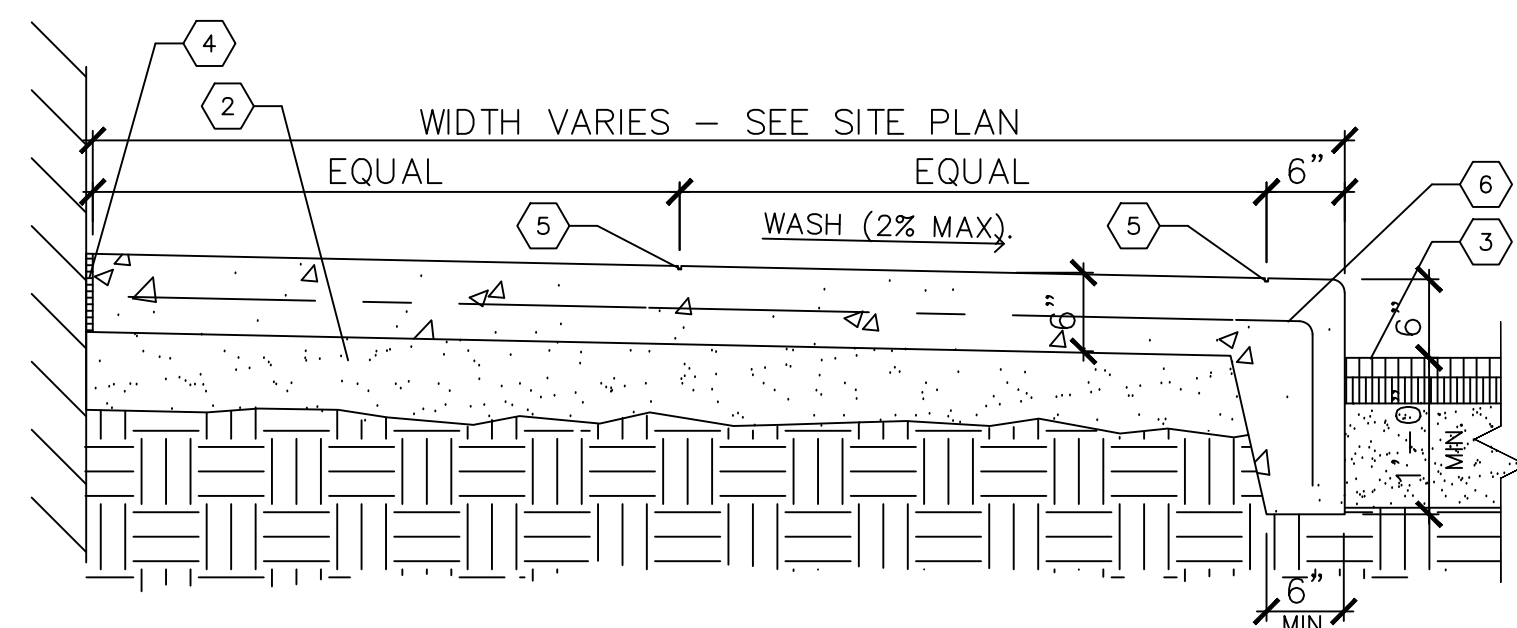

KEYED NOTES

- 1 N/A
- 2 4" COMPACTED AGGREGATE BASE
- 3 PAVEMENT.
- 4 COMPRESSIBLE FILLER (3/4" MAXIMUM). CUT BACK AND PROVIDE SEALANT, TYPICAL, AT ALL JOINTS WITH FILLER.
- 5 1/4" TOOLED JOINT
- 6 6" X 6" #10 W.W.F.

NOTE: EXPANSION JOINT 20' O.C. MAXIMUM. 1/4" TOOL JOINT 4' O.C. OR AS DIRECTED. CONCRETE TO BE 4000 P.S.I.

MONOLITHIC CONCRETE CURB AND SIDEWALK DETAIL

N.T.S. WAG

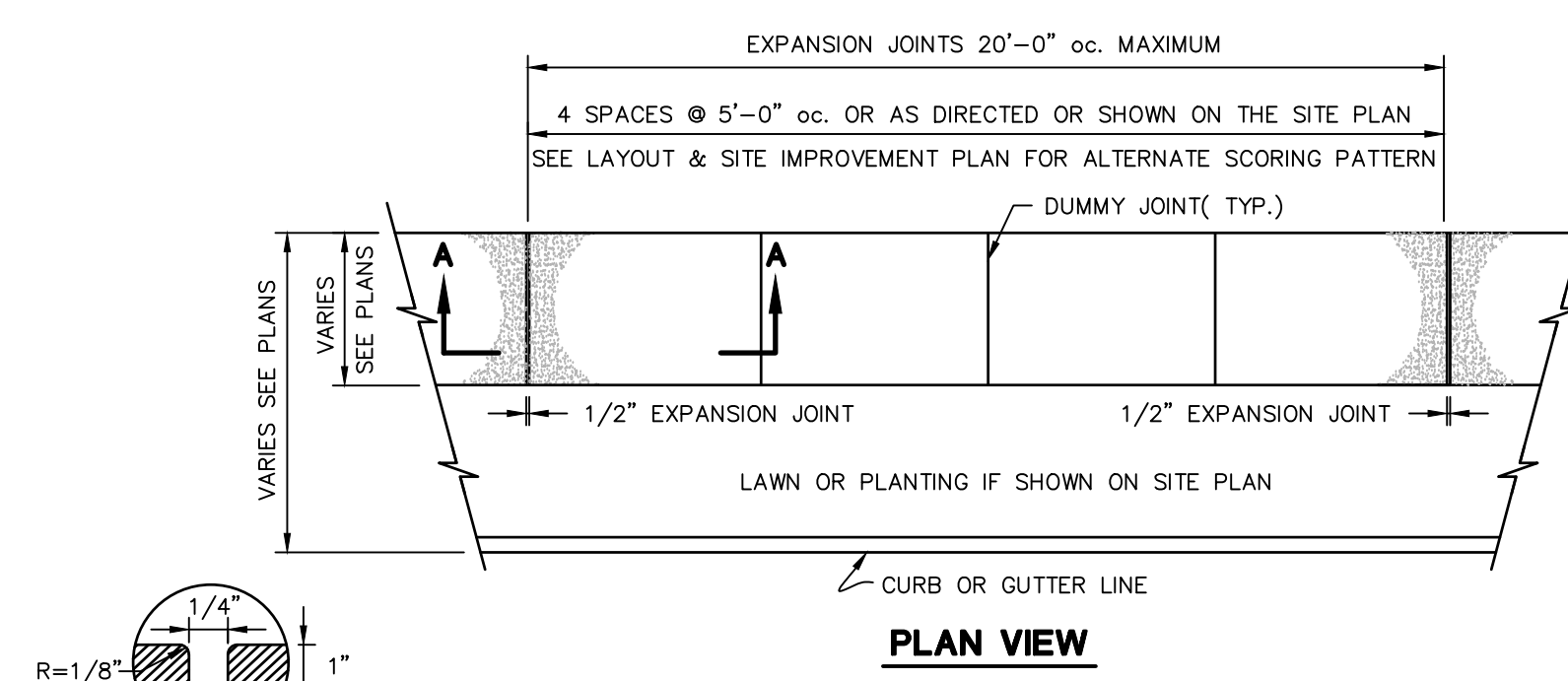

CONCRETE SIDEWALK DETAIL

N.T.S. BLSR-001

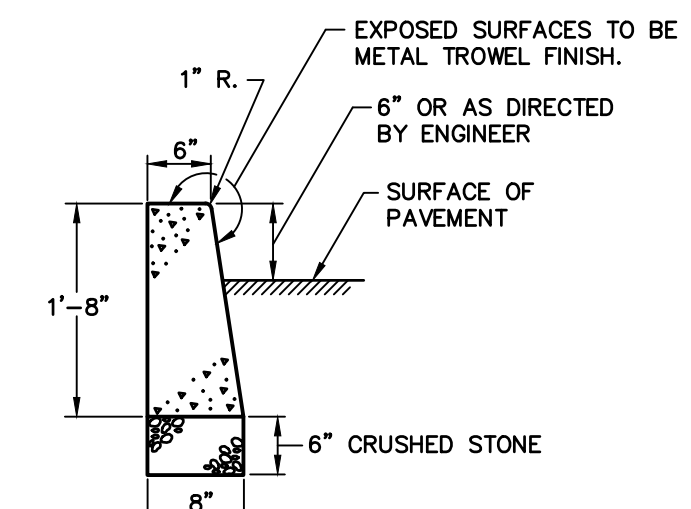

CONCRETE CURB DETAIL

N.T.S. ZPC-014

NOTE:
1. CONSTRUCTION JOINTS SHALL BE SPACED APPROXIMATELY EVERY 10 FEET BUT NOT LESS THAN 6 FEET. 1/4" THICK PREFORMED EXPANSION JOINT FILLER SHALL BE INSTALLED EVERY OTHER JOINT.
2. FORMWORK SHALL REMAIN IN PLACE FOR 24 HOURS FOLLOWING CONCRETE POURING.

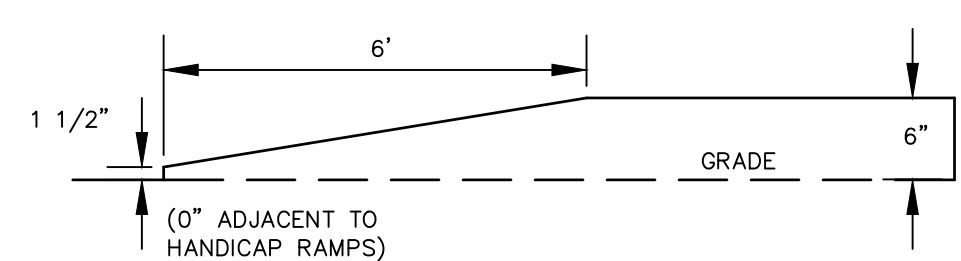

TRANSITION CURB

N.T.S.

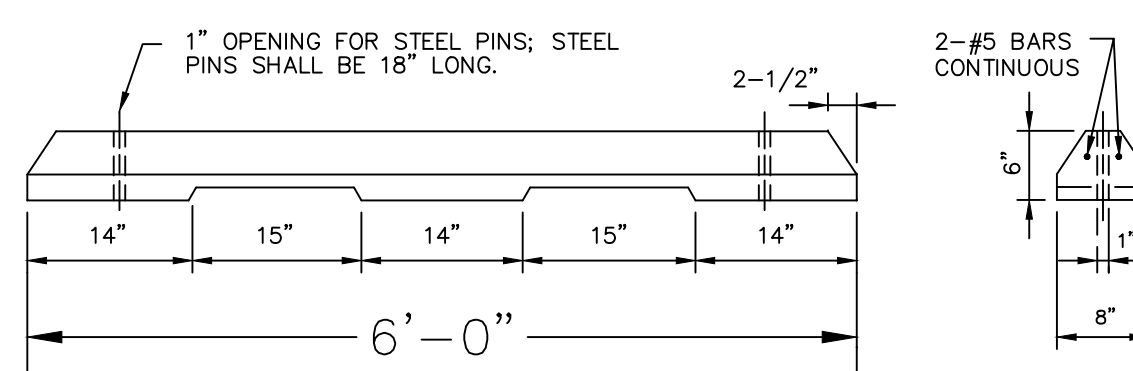

CONCRETE CURB STOP

N.T.S. BLP-001

FOR PERMITTING PURPOSES ONLY
NOT RELEASED FOR CONSTRUCTION

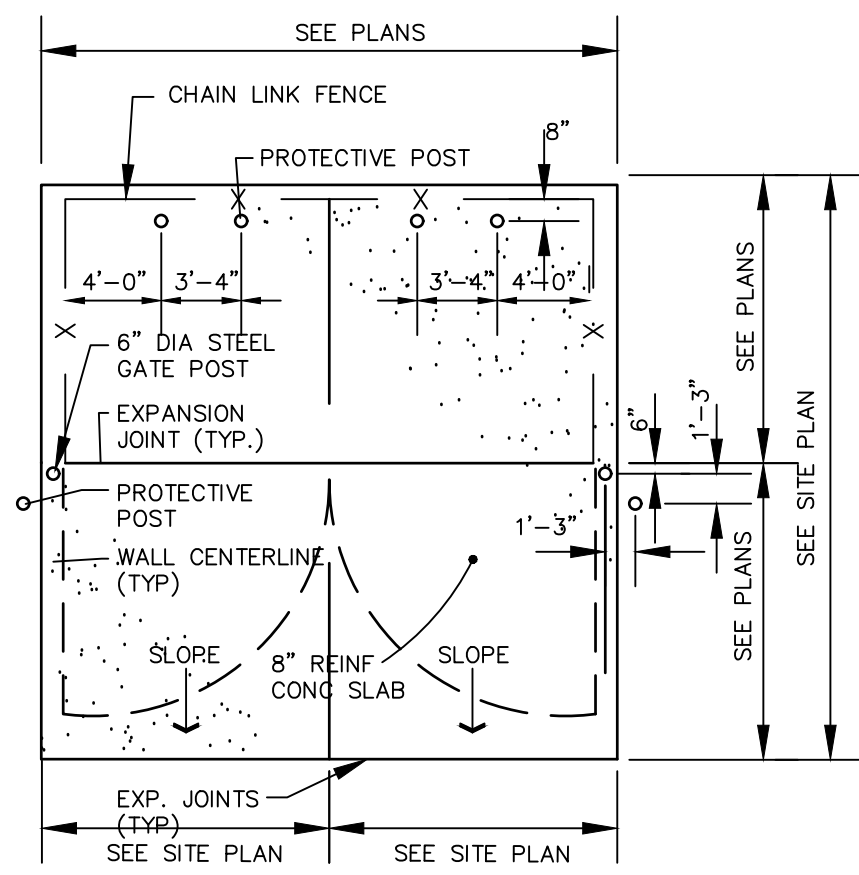

TRASH ENCLOSURE PLAN

N.T.S. BLSE-004

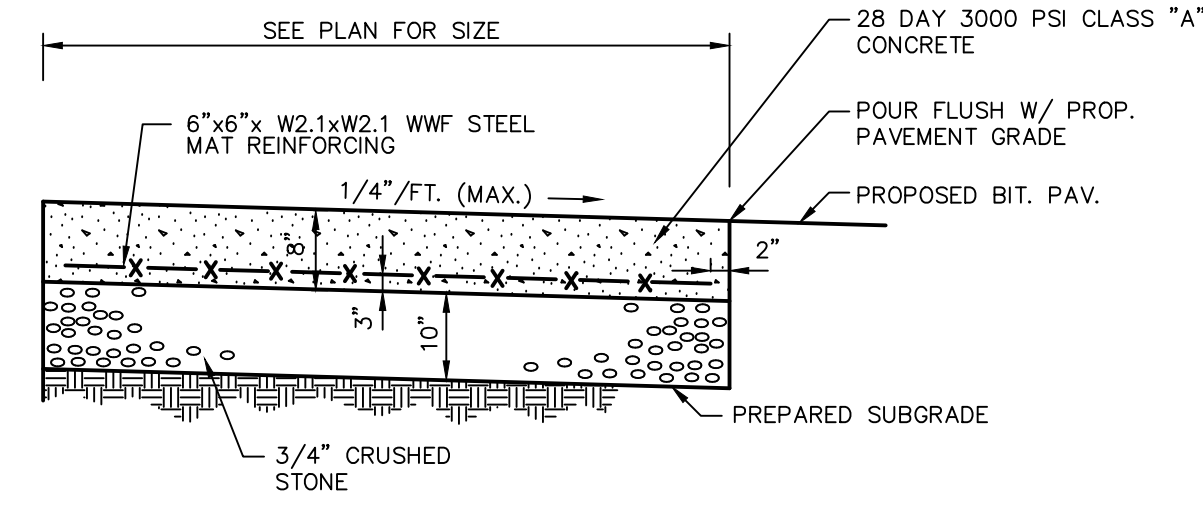

CONCRETE DUMPSTER PAD AND CONCRETE PAVEMENT

N.T.S. BLPC-002

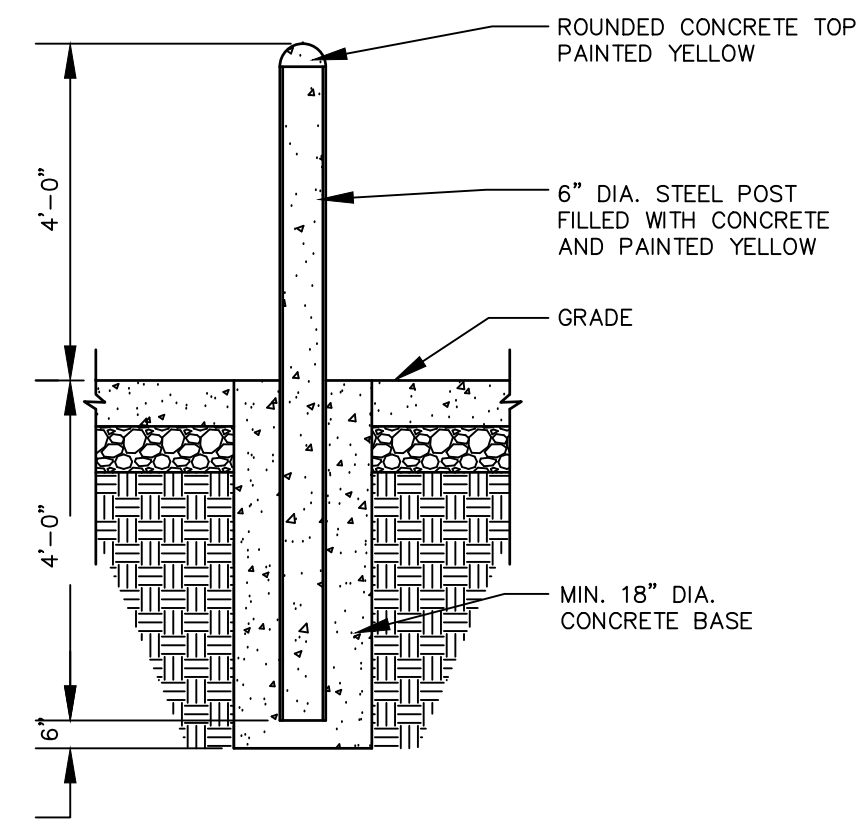

PROTECTIVE POST (BOLLARD) DETAIL

N.T.S. BLSE-005

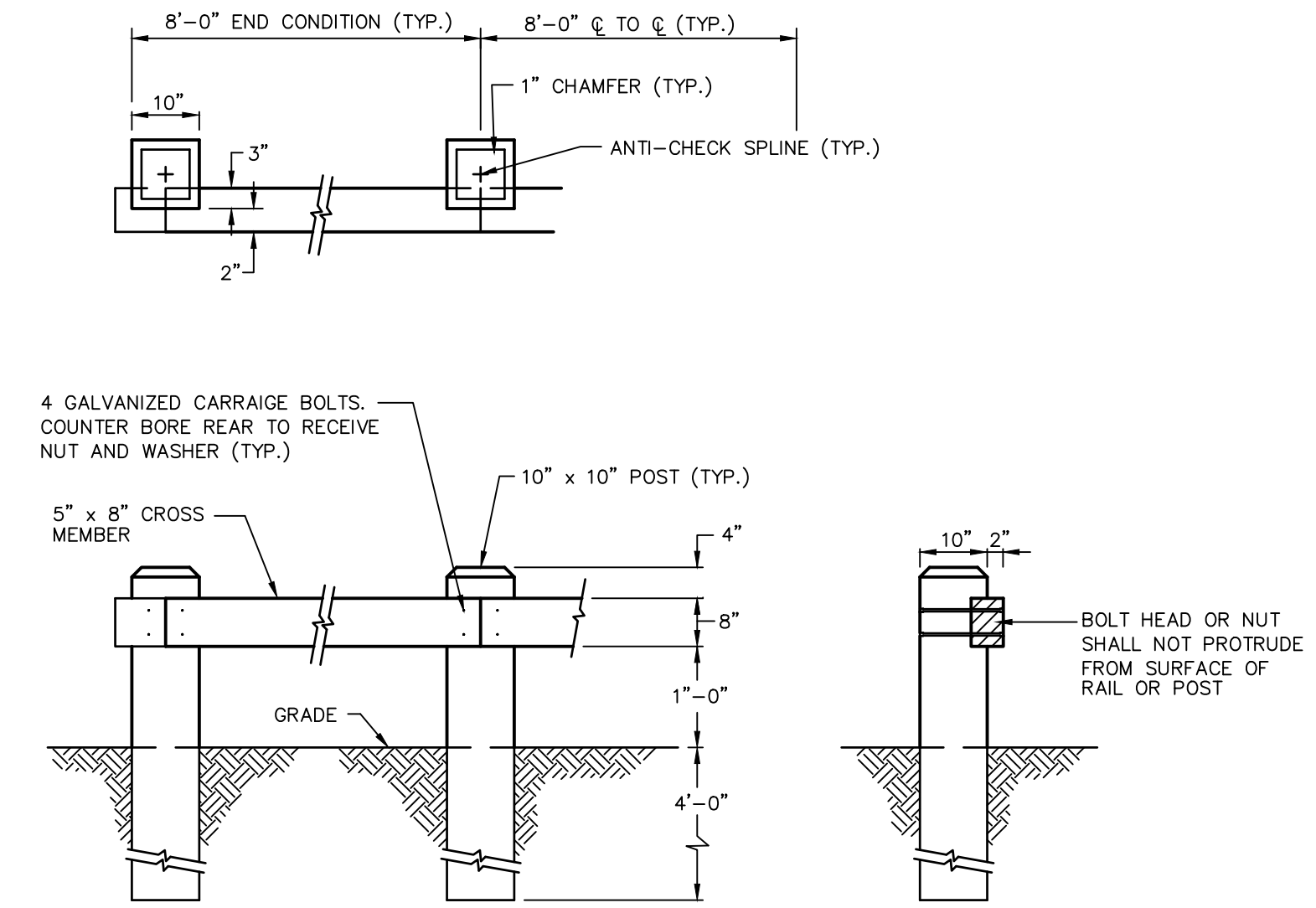

TIMBER GUIDE RAIL

N.T.S. BLGR-002

NOTE:
1. ALL TIMBER TO BE PRESSURE TREATED CCA=40 PCF SOUTHERN YELLOW PINE.

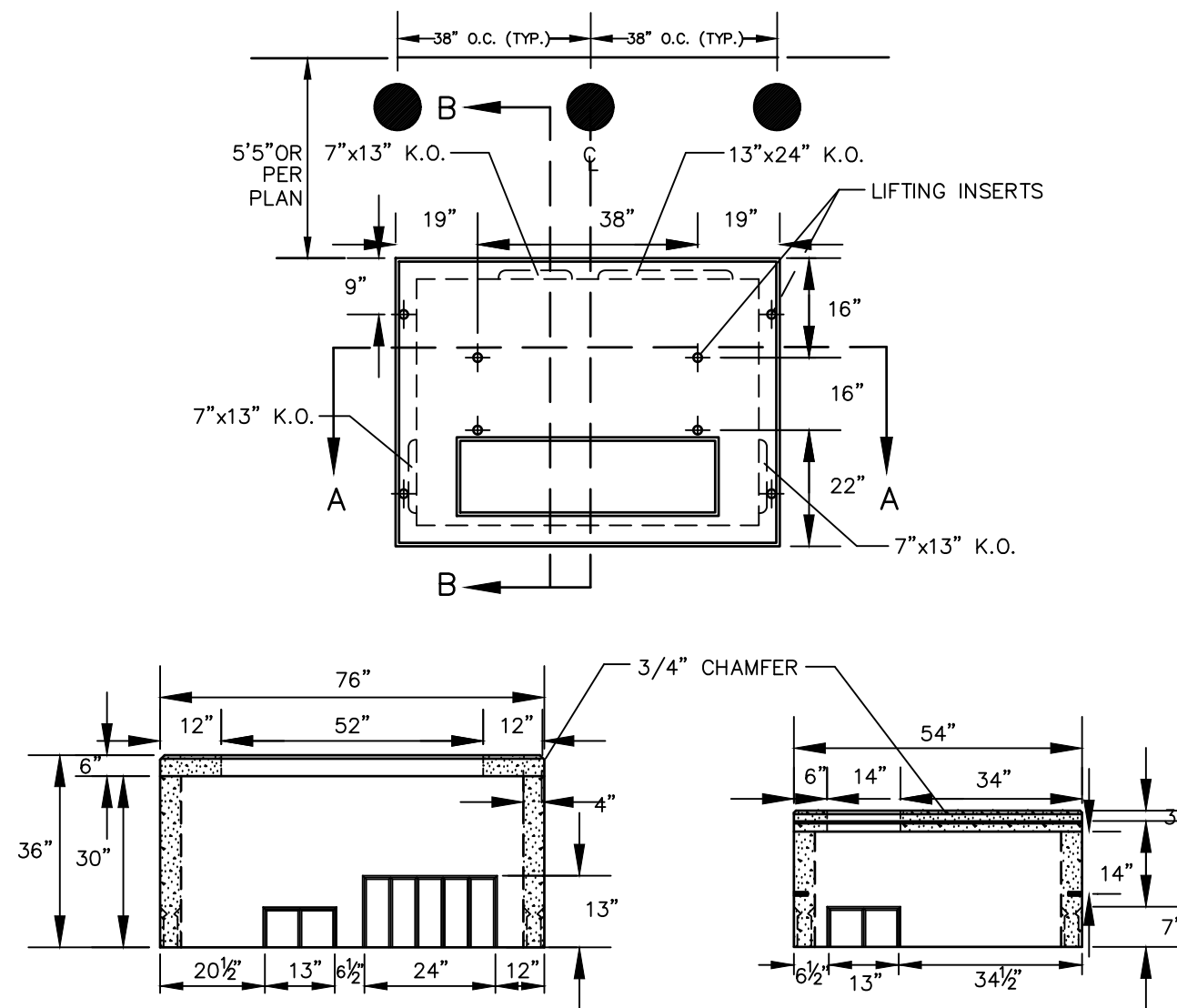

SECTION A-A

SECTION B-B

NOTES:
1. CONCRETE COMPRESSIVE STRENGTH SHALL BE 4000 PSI AT 28 DAYS
2. SHALL MEET ALL PROVISIONS OF ELECTRIC CO.
3. SHALL BE INSTALLED 2' MINIMUM OFF CURB AND PROTECTED BY BOLLARDS.
4. SEE DETAIL FOR STEEL BOLLARD INSTALLATION
5. CONTRACTOR SHALL CONFIRM PAD SIZE AND BOLLARD LOCATION WITH ELECTRIC COMPANY

CONCRETE TRANSFORMER PAD

N.T.S.

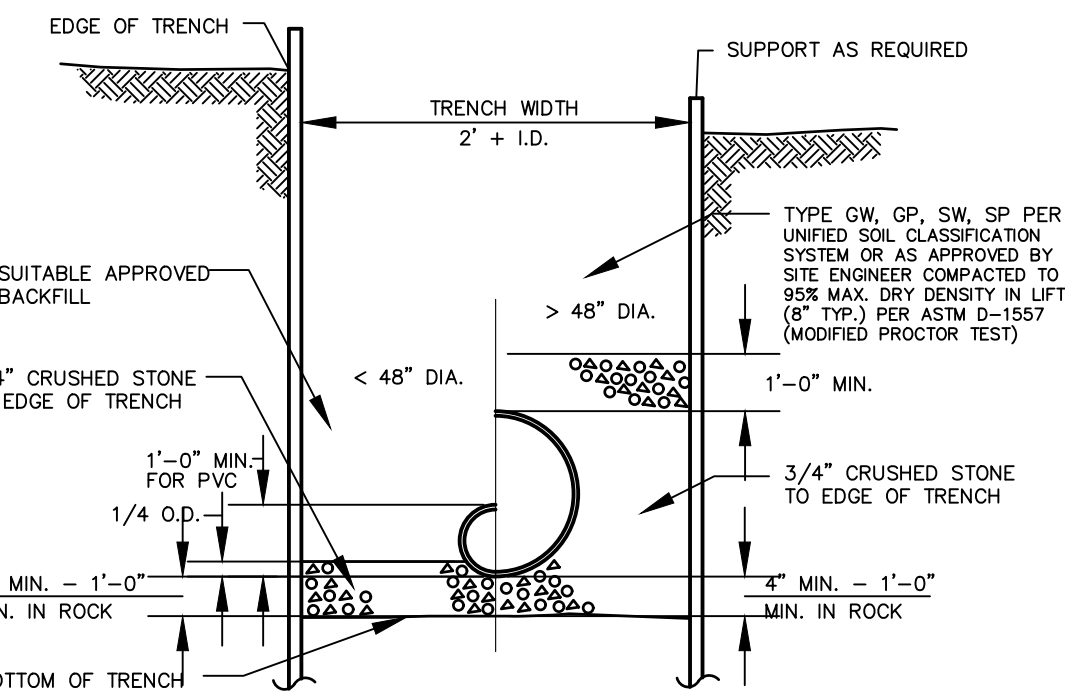

TYPICAL STORM SEWER TRENCH SECTION

N.T.S. BLDD-004

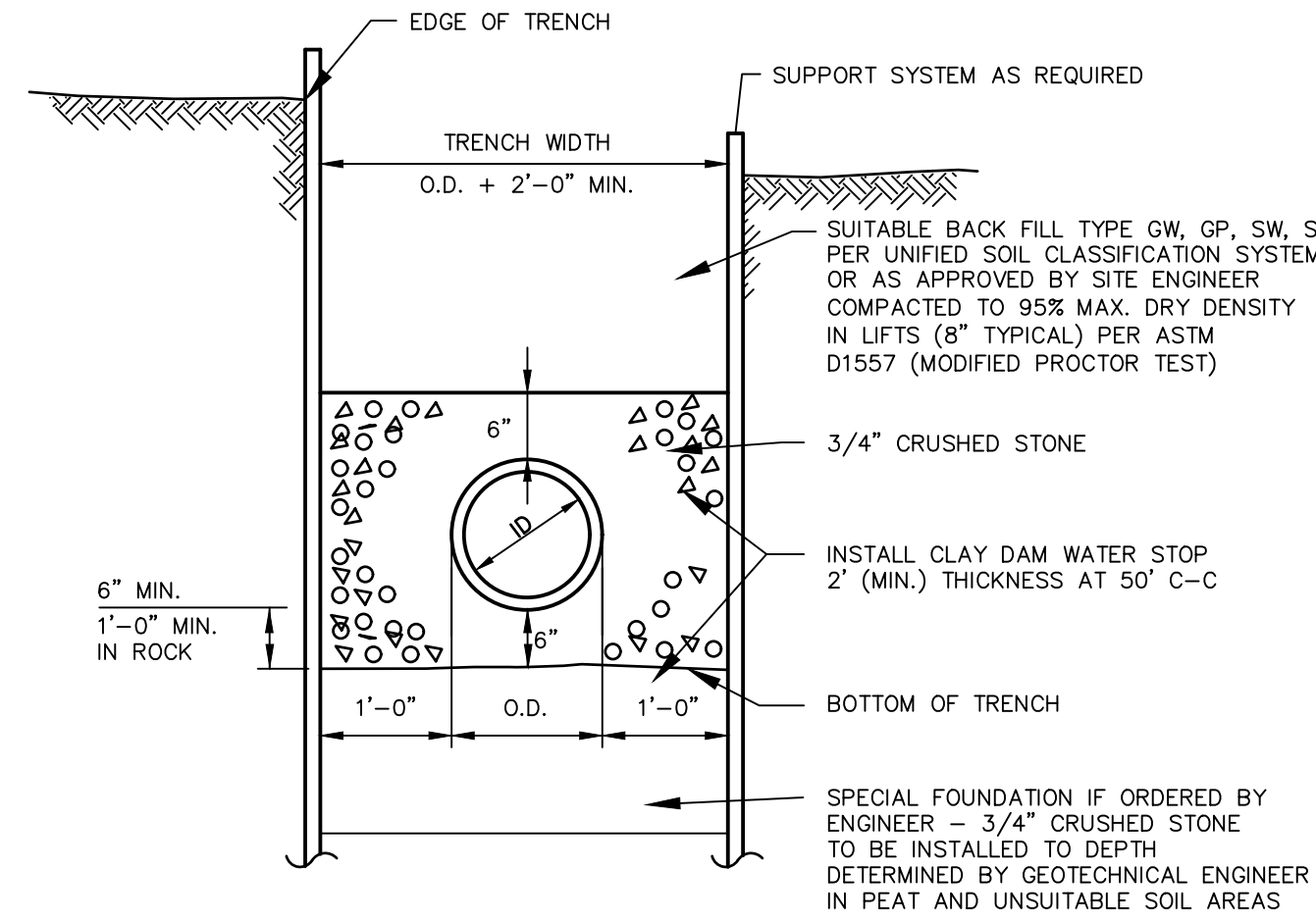

TYPICAL SANITARY SEWER TRENCH SECTION

N.T.S. BLSS-010

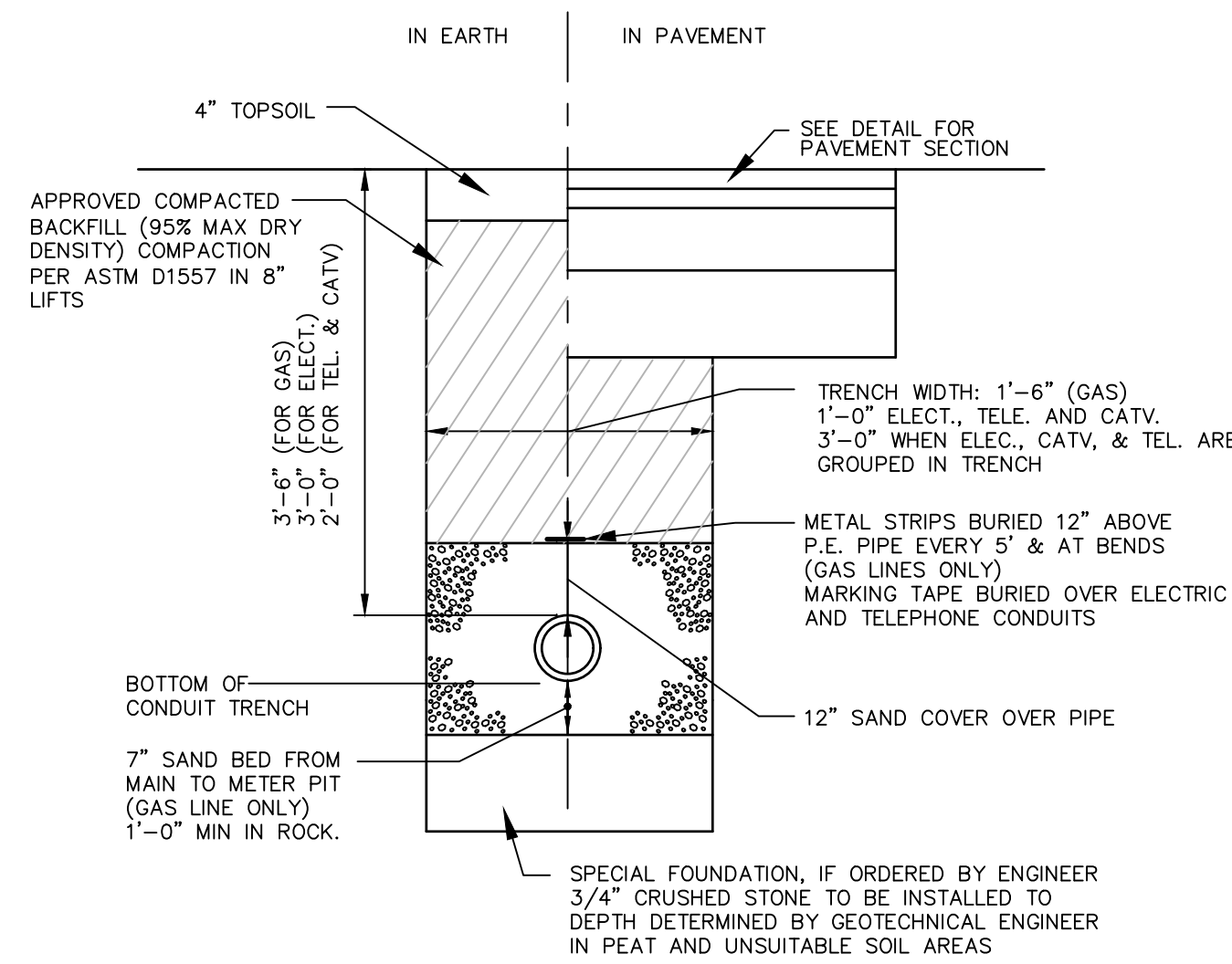

ELECTRICAL, TELEPHONE AND GAS TRENCH DETAIL

N.T.S. BLUD-001

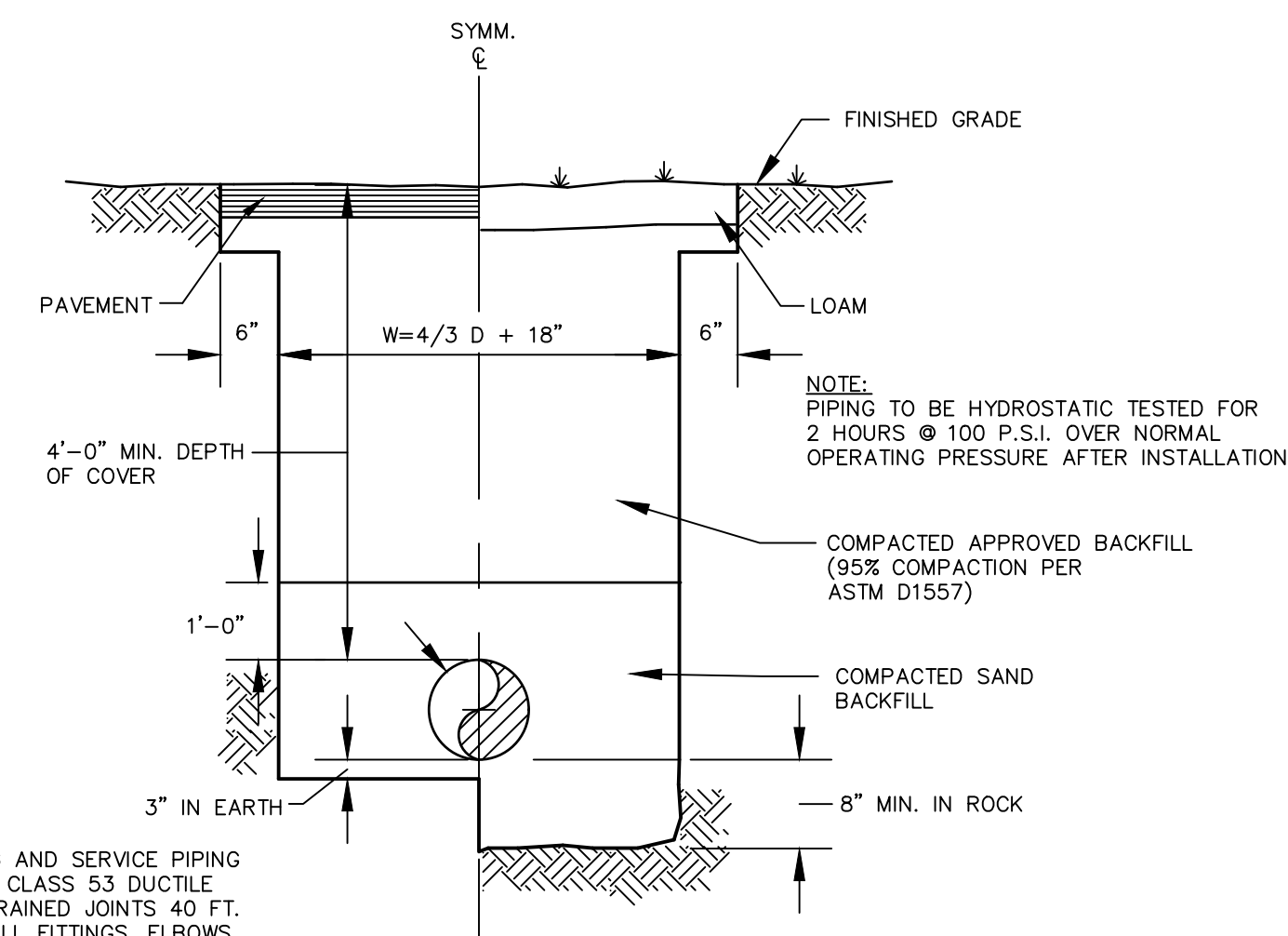

TYPICAL WATER MAIN AND SERVICE TRENCH DETAIL

N.T.S. BLWD-005

NOTE:
FIRE LINE PIPING AND SERVICE PIPING > 3" I.D. TO BE CLASS 53 DUCTILE IRON WITH RESTRAINED JOINTS 40 FT. EACH SIDE OF ALL FITTINGS, ELBOWS AND APPURTENANCES. DOMESTIC PIPING < 3" I.D. TO BE TYPE K COPPER PER ASTM B 88.

STORMTECH CHAMBER SPECIFICATIONS

- CHAMBERS SHALL BE STORMTECH SC-740.
- CHAMBERS SHALL BE MANUFACTURED FROM VIRGIN POLYPROPYLENE OR POLYETHYLENE RESINS.
- CHAMBER ROWS SHALL PROVIDE CONTINUOUS, UNOBSTRUCTED INTERNAL SPACE WITH NO INTERNAL SUPPORT PANELS THAT WOULD IMPERF FLOW OR LIMIT ACCESS FOR INSPECTION.
- THE STRUCTURAL DESIGN OF THE CHAMBERS, THE STRUCTURAL BACKFILL, AND THE INSTALLATION REQUIREMENTS SHALL ENSURE THAT THE LOAD FACTORS SPECIFIED IN THE AASHTO LRFD BRIDGE DESIGN SPECIFICATIONS, SECTION 12.12 ARE MET FOR: 1) LONG-DURATION DEAD LOADS AND 2) SHORT-DURATION LIVE LOADS, BASED ON THE AASHTO DESIGN TRUCK WITH CONSIDERATION FOR IMPACT AND MULTIPLE VEHICLE PRESENCES.
- CHAMBERS SHALL MEET ASTM F2822 (POLYETHYLENE) OR ASTM F2418-16 (POLYPROPYLENE), "STANDARD SPECIFICATION FOR THERMOPLASTIC CORRUGATED WALL STORMWATER COLLECTION CHAMBERS".
- CHAMBERS SHALL BE DESIGNED AND ALLOWABLE LOADS DETERMINED IN ACCORDANCE WITH ASTM F2787, "STANDARD PRACTICE FOR STRUCTURAL DESIGN OF THERMOPLASTIC CORRUGATED WALL STORMWATER COLLECTION CHAMBERS".
- ONLY CHAMBERS THAT ARE APPROVED BY THE SITE DESIGN ENGINEER WILL BE ALLOWED. THE CHAMBER MANUFACTURER SHALL SUBMIT THE FOLLOWING UPON REQUEST TO THE SITE DESIGN ENGINEER FOR APPROVAL BEFORE DELIVERING CHAMBERS TO THE PROJECT SITE:
 - A STRUCTURAL EVALUATION SEALED BY A REGISTERED PROFESSIONAL ENGINEER THAT DEMONSTRATES THAT THE SAFETY FACTORS ARE GREATER THAN OR EQUAL TO 1.95 FOR DEAD LOAD AND 1.75 FOR LIVE LOAD, THE MINIMUM REQUIRED BY ASTM F2787 AND BY AASHTO FOR THERMOPLASTIC PIPE.
 - A STRUCTURAL EVALUATION SEALED BY A REGISTERED PROFESSIONAL ENGINEER THAT DEMONSTRATES THAT THE LOAD FACTORS SPECIFIED IN THE AASHTO LRFD BRIDGE DESIGN SPECIFICATIONS, SECTION 12.12, ARE MET. THE 50-YEAR CREEP MODULUS DATA SPECIFIED IN ASTM F2418 OR ASTM F2822 MUST BE USED AS PART OF THE AASHTO STRUCTURAL EVALUATION TO VERIFY LONG-TERM PERFORMANCE.
 - STRUCTURAL CROSS SECTION DETAIL ON WHICH THE STRUCTURAL EVALUATION IS BASED.
- CHAMBERS AND END CAPS SHALL BE PRODUCED AT AN ISO 9001 CERTIFIED MANUFACTURING FACILITY.

IMPORTANT - NOTES FOR THE BIDDING AND INSTALLATION OF THE SC-310/SC-740 SYSTEM

- STORMTECH SC-310 & SC-740 CHAMBERS SHALL NOT BE INSTALLED UNTIL THE MANUFACTURER'S REPRESENTATIVE HAS COMPLETED A PRE-CONSTRUCTION MEETING WITH THE INSTALLERS.
- STORMTECH SC-310 & SC-740 CHAMBERS SHALL BE INSTALLED IN ACCORDANCE WITH THE "STORMTECH SC-310/SC-740DC-780 CONSTRUCTION GUIDE".
- CHAMBERS ARE NOT TO BE BACKFILLED WITH A DOZER OR AN EXCAVATOR SITUATED OVER THE CHAMBERS. STORMTECH RECOMMENDS 3 BACKFILL METHODS:
 - STONE SHOOTER LOCATED OFF THE CHAMBER BED.
 - BACKFILL AS ROWS ARE BUILT USING AN EXCAVATOR ON THE FOUNDATION STONE OR SUBGRADE.
 - BACKFILL FROM OUTSIDE THE EXCAVATION USING A LONG BOOM HOE OR EXCAVATOR.
- THE FOUNDATION STONE SHALL BE LEVELED AND COMPACTED PRIOR TO PLACING CHAMBERS.
- JOINTS BETWEEN CHAMBERS SHALL BE PROPERLY SEATED PRIOR TO PLACING STONE.
- MAINTAIN MINIMUM-6" (150 mm) SPACING BETWEEN THE CHAMBER ROWS.
- EMBEDMENT STONE SURROUNDING CHAMBERS MUST BE A CLEAN, CRUSHED, ANGULAR STONE 3/4"-2" (20-50 mm).
- THE CONTRACTOR MUST REPORT ANY DISCREPANCIES WITH CHAMBER FOUNDATION MATERIALS BEARING CAPACITIES TO THE SITE DESIGN ENGINEER.
- PROVIDE "FLEXSTORM CATCH IT" INSERTS DURING CONSTRUCTION FOR ALL INLETS TO PROTECT THE SUBSURFACE STORMWATER MANAGEMENT SYSTEM FROM CONSTRUCTION SITE RUNOFF.

NOTES FOR CONSTRUCTION EQUIPMENT

- STORMTECH SC-310 & SC-740 CHAMBERS SHALL BE INSTALLED IN ACCORDANCE WITH THE "STORMTECH SC-310/SC-740DC-780 CONSTRUCTION GUIDE".
- THE USE OF CONSTRUCTION EQUIPMENT OVER SC-310 & SC-740 CHAMBERS IS LIMITED:
 - NO EQUIPMENT IS ALLOWED ON BARE CHAMBERS.
 - NO RUBBER Tired LOADERS, DUMP TRUCKS, OR EXCAVATORS ARE ALLOWED UNTIL PROPER FILL DEPTHS ARE REACHED IN ACCORDANCE WITH THE "STORMTECH SC-310/SC-740DC-780 CONSTRUCTION GUIDE".
 - WEIGHT LIMITS FOR CONSTRUCTION EQUIPMENT CAN BE FOUND IN THE "STORMTECH SC-310/SC-740DC-780 CONSTRUCTION GUIDE".
- FULL 36" (900 mm) OF STABILIZED COVER MATERIALS OVER THE CHAMBERS IS REQUIRED FOR DUMP TRUCK TRAVEL OR DUMPING.

USE OF A DOZER TO PUSH EMBEDMENT STONE BETWEEN THE ROWS OF CHAMBERS MAY CAUSE DAMAGE TO THE CHAMBERS AND IS NOT AN ACCEPTABLE BACKFILL METHOD. ANY CHAMBERS DAMAGED BY THE "DUMP AND PUSH" METHOD ARE NOT COVERED UNDER THE STORMTECH STANDARD WARRANTY.

CONTACT STORMTECH AT 1-888-892-2894 WITH ANY QUESTIONS ON INSTALLATION REQUIREMENTS OR WEIGHT LIMITS FOR CONSTRUCTION EQUIPMENT.

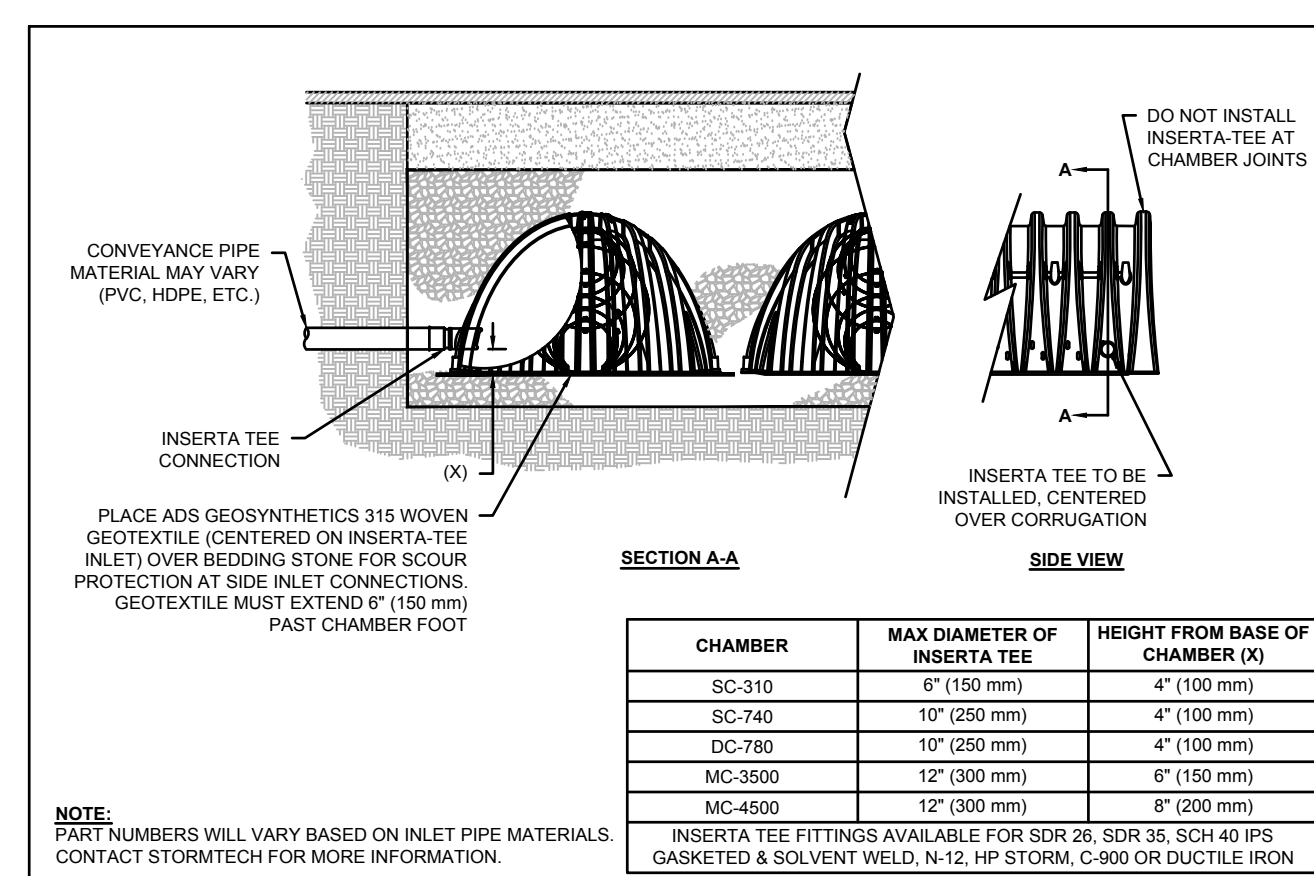

6 INSERTA-TEE SIDE INLET DETAIL

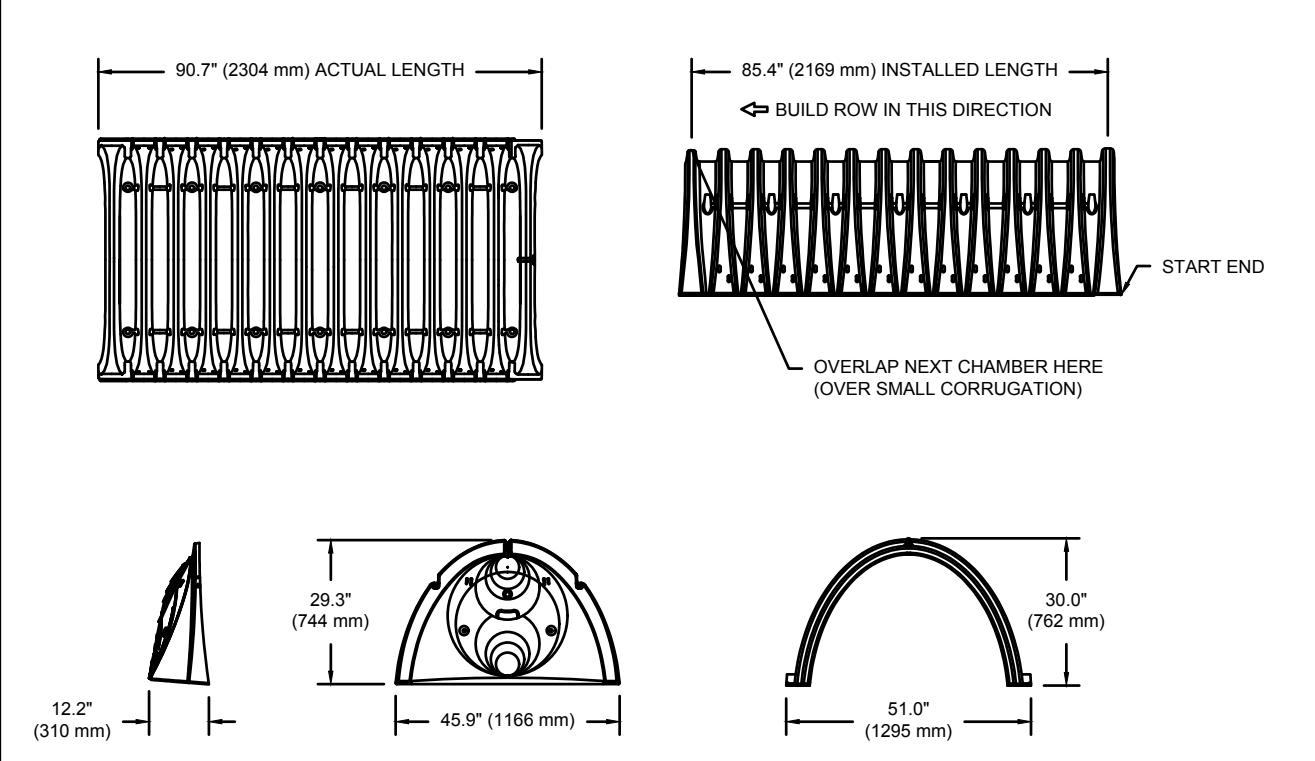

NOMINAL CHAMBER SPECIFICATIONS

SIZE (W X H X INSTALLED LENGTH)	51.0" X 30.0" X 85.4"	(1295 mm X 762 mm X 2169 mm)
CHAMBER STORAGE	45.9 CUBIC FEET (1.30 m ³)	45.9 CUBIC FEET (1.30 m ³)
MINIMUM INSTALLED STORAGE*	74.9 CUBIC FEET (2.12 m ³)	74.9 CUBIC FEET (2.12 m ³)
WEIGHT	75.0 lbs.	(33.6 kg)

*ASSUMES 6" (152 mm) STONE ABOVE, BELOW, AND BETWEEN CHAMBERS

PRE-FAB STUBS AT BOTTOM OF END CAP FOR PART NUMBERS ENDING WITH "B"
PRE-FAB STUBS AT TOP OF END CAP FOR PART NUMBERS ENDING WITH "T"
PRE-CORDED END CAPS END WITH "PC"

ALL STUBS, EXCEPT FOR THE SC740EPE24B ARE PLACED AT BOTTOM OF END CAP SUCH THAT THE OUTSIDE DIAMETER OF THE STUB IS FLUSH WITH THE BOTTOM OF THE END CAP. FOR ADDITIONAL INFORMATION CONTACT STORMTECH AT 1-888-892-2894.

* FOR THE SC740EPE24B THE 24" (600 mm) STUB LIES BELOW THE BOTTOM OF THE END CAP APPROXIMATELY 1.75" (44 mm). BACKFILL MATERIAL SHOULD BE REMOVED FROM BELOW THE N-12 STUB SO THAT THE FITTING SITS LEVEL.

NOTE: ALL DIMENSIONS ARE NOMINAL

2 SC-740 TECHNICAL SPECIFICATIONS

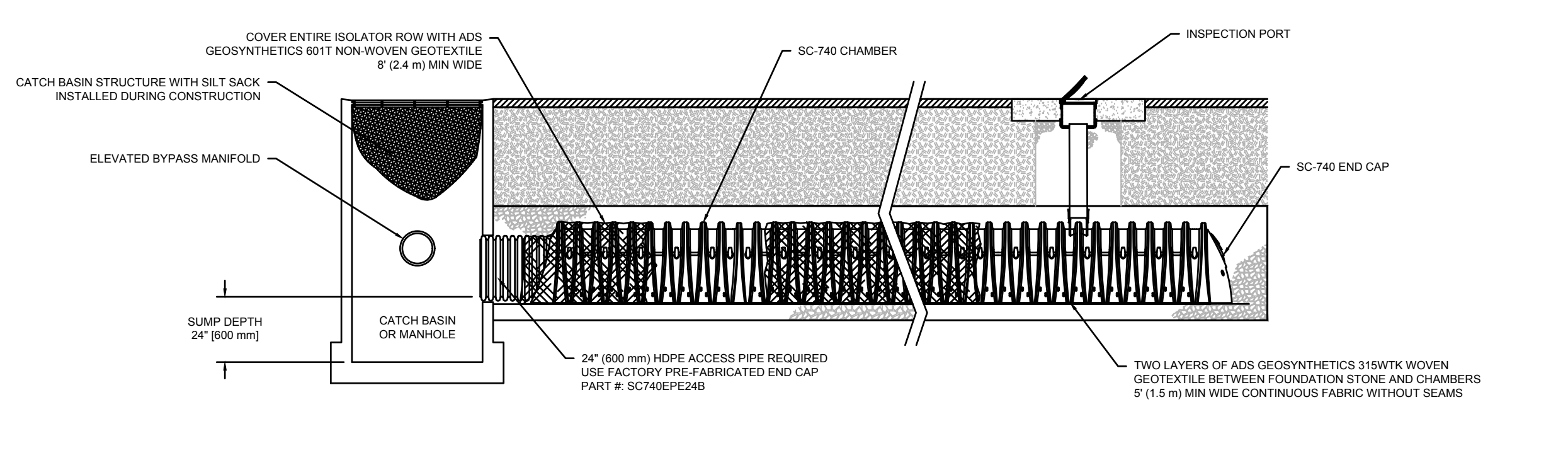

3 SC-740 ISOLATOR ROW DETAIL

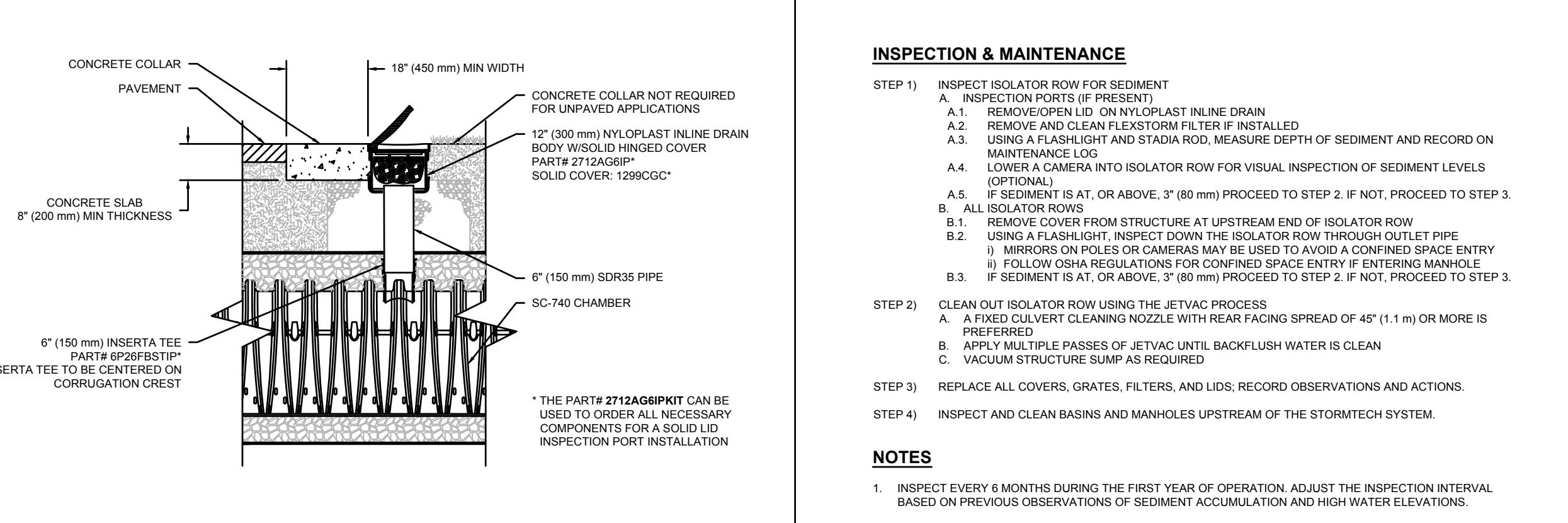

4 SC-740 6" (150 mm) INSPECTION PORT DETAIL

ACCEPTABLE FILL MATERIALS: STORMTECH SC-740 CHAMBER SYSTEMS

MATERIAL LOCATION	DESCRIPTION	AASHTO MATERIAL CLASSIFICATIONS	COMPACTION / DENSITY REQUIREMENT
D	FINAL FILL: FILL MATERIAL FOR LAYER 'D' STARTS FROM THE TOP OF THE 'C' LAYER TO THE BOTTOM OF FLEXIBLE PAVEMENT OR UNPAVED FINISHED GRADE ABOVE. NOTE THAT PAVEMENT SUBBASE MAY BE PART OF THE 'D' LAYER.	N/A	PREPARE PER SITE DESIGN ENGINEER'S PLANS. PAVED INSTALLATIONS MAY HAVE STRINGENT MATERIAL AND PREPARATION REQUIREMENTS.
C	INITIAL FILL: FILL MATERIAL FOR LAYER 'C' STARTS FROM THE TOP OF THE EMBEDMENT STONE 'B' LAYER TO 18" (450 mm) ABOVE THE TOP OF THE CHAMBER. NOTE THAT PAVEMENT SUBBASE MAY BE A PART OF THE 'C' LAYER.	AASHTO M145 A-1, A-2.4, A-3 OR AASHTO M43 3, 357, 4, 467, 5, 56, 57, 6, 67, 68, 7, 7B, 8, 8B, 9, 10	BEGIN COMPACTIONS AFTER 12" (300 mm) OF MATERIAL OVER THE CHAMBERS IS REACHED. COMPACT ADDITIONAL LAYERS IN 6" (150 mm) MAX LIFTS TO A MIN. 95% PROCTOR DENSITY FOR WELL GRADED MATERIAL AND 95% RELATIVE DENSITY FOR PROCESSED AGGREGATE MATERIALS. ROLLER GROSS VEHICLE WEIGHT NOT TO EXCEED 12,000 lbs (53 kN). DYNAMIC FORCE NOT TO EXCEED 20,000 lbs (89 kN).
B	EMBEDMENT STONE: FILL SURROUNDING THE CHAMBERS FROM THE FOUNDATION STONE ('A' LAYER) TO THE 'C' LAYER ABOVE.	AASHTO M43 3, 357, 4, 467, 5, 56, 57	NO COMPACTION REQUIRED.
A	FOUNDATION STONE: FILL BELOW CHAMBERS FROM THE SUBGRADE UP TO THE FOOT (BOTTOM) OF THE CHAMBER.	AASHTO M43 3, 357, 4, 467, 5, 56, 57	PLATE COMPACT OR ROLL TO ACHIEVE A FLAT SURFACE. ^{1,2}

PLEASE NOTE:
1. THE LISTED AASHTO DESIGNATIONS ARE FOR GRADATIONS ONLY. THE STONE MUST ALSO BE CLEAN, CRUSHED, ANGULAR. FOR EXAMPLE, A SPECIFICATION FOR #4 STONE WOULD STATE: "CLEAN, CRUSHED, ANGULAR NO. 4 (AASHTO M43) STONE".
2. STORMTECH COMPACTION REQUIREMENTS ARE MET FOR 'A' LOCATION MATERIALS WHEN PLACED AND COMPACTED IN 6" (150 mm) (MAX) LIFTS USING TWO FULL COVERAGES WITH A VIBRATORY COMPACTOR.
3. WHERE INFILTRATION SURFACES MAY BE COMPROMISED BY COMPACTION, FOR STANDARD DESIGN LOAD CONDITIONS, A FLAT SURFACE MAY BE ACHIEVED BY RAKING OR DRAGGING WITHOUT COMPACTION EQUIPMENT. FOR SPECIAL LOAD DESIGNS, CONTACT STORMTECH FOR COMPACTION REQUIREMENTS.

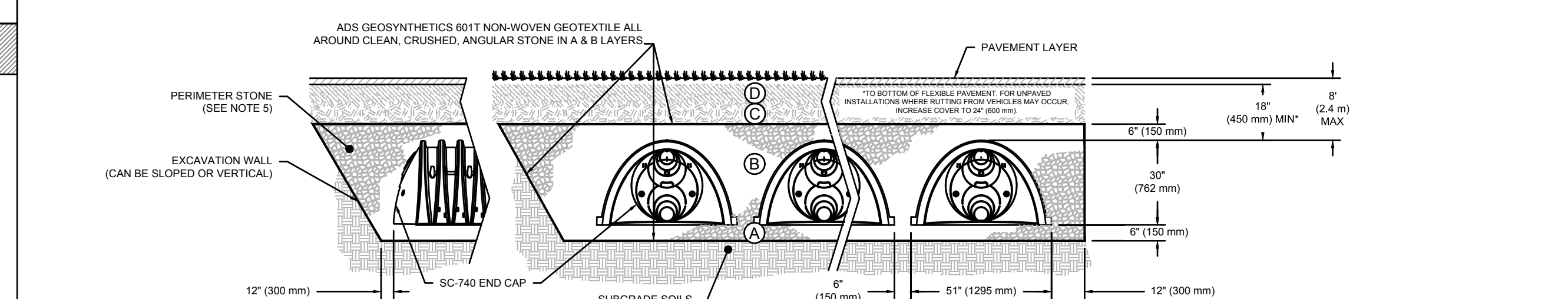

- NOTES:**
- SC-740 CHAMBERS SHALL CONFORM TO THE REQUIREMENTS OF ASTM F2418 "STANDARD SPECIFICATION FOR POLYPROPYLENE (PP) CORRUGATED WALL STORMWATER COLLECTION CHAMBERS", OR ASTM F2822 "STANDARD SPECIFICATION FOR POLYETHYLENE (PE) CORRUGATED WALL STORMWATER COLLECTION CHAMBERS".
 - SC-740 CHAMBERS SHALL BE DESIGNED IN ACCORDANCE WITH ASTM F2787 "STANDARD PRACTICE FOR STRUCTURAL DESIGN OF THERMOPLASTIC CORRUGATED WALL STORMWATER COLLECTION CHAMBERS".
 - "ACCEPTABLE FILL MATERIALS" TABLE ABOVE PROVIDES MATERIAL LOCATIONS, DESCRIPTIONS, GRADATIONS, AND COMPACTION REQUIREMENTS FOR FOUNDATION, EMBEDMENT, AND FILL MATERIALS.
 - PERIMETER STONE MUST BE EXTENDED HORIZONTALLY TO THE EXCAVATION WALL FOR BOTH VERTICAL AND SLOPED EXCAVATION WALLS.
 - ONCE LAYER 'C' IS PLACED, ANY SOIL MATERIAL CAN BE PLACED IN LAYER 'D' UP TO THE FINISHED GRADE. MOST PAVEMENT SUBBASE SOILS CAN BE USED TO REPLACE THE MATERIAL REQUIREMENTS OF LAYER 'C' OR 'D' AT THE SITE DESIGN ENGINEER'S DISCRETION.

1 SC-740 CROSS SECTION DETAIL



REVIS/CS	Date	Desc.
No.		

Designed X.X.X.
Drawn X.X.X.
Reviewed J.J.S.
Scale NONE
Project No. 2202472
Date 03/10/2023
CAD File: DN220247201

Title
DETAILS SHEET

Sheet No.

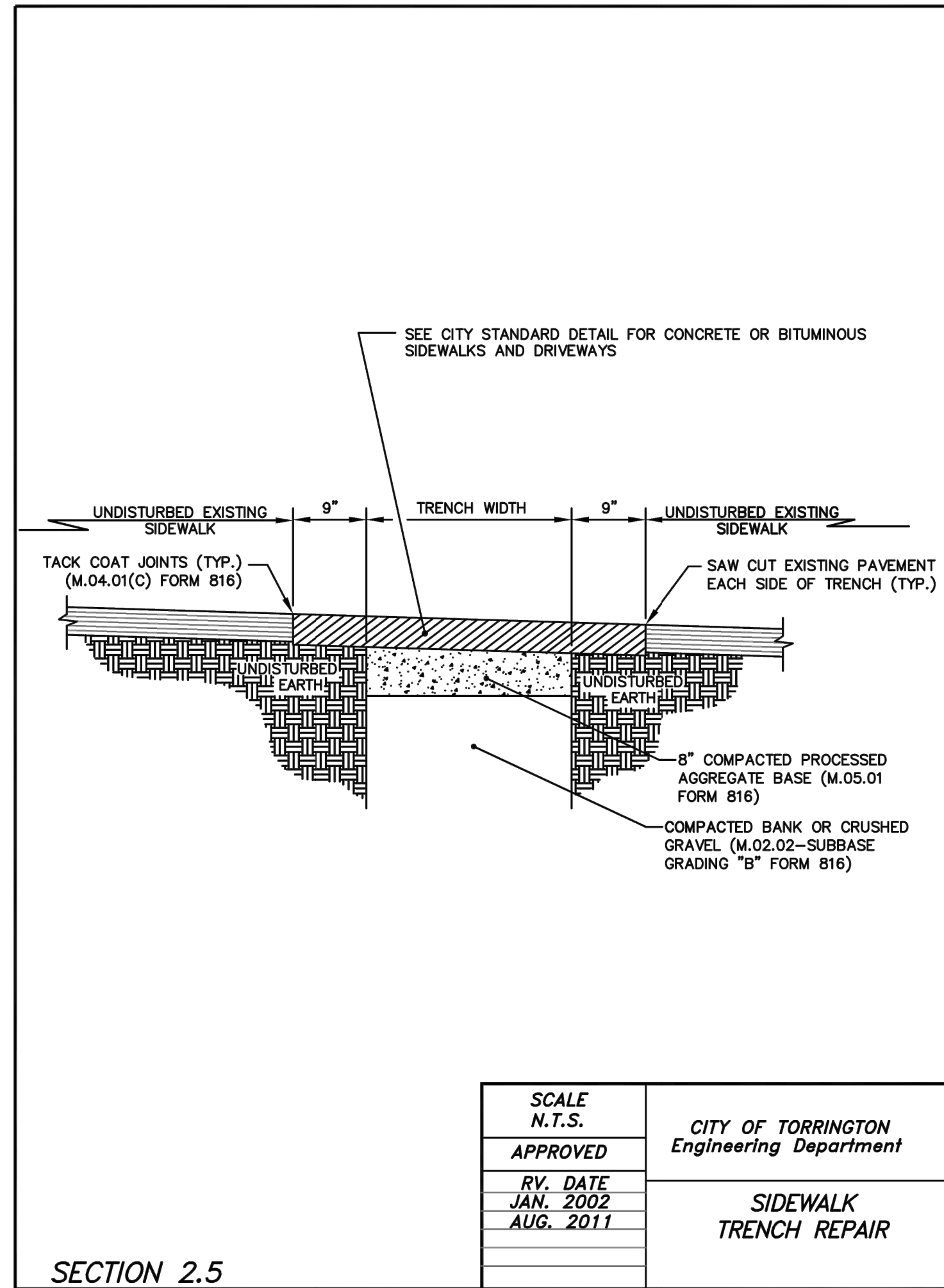

SCALE N.T.S.	CITY OF TORRINGTON Engineering Department
APPROVED	
RV. DATE JAN. 2002 AUG. 2011	SIDEWALK TRENCH REPAIR

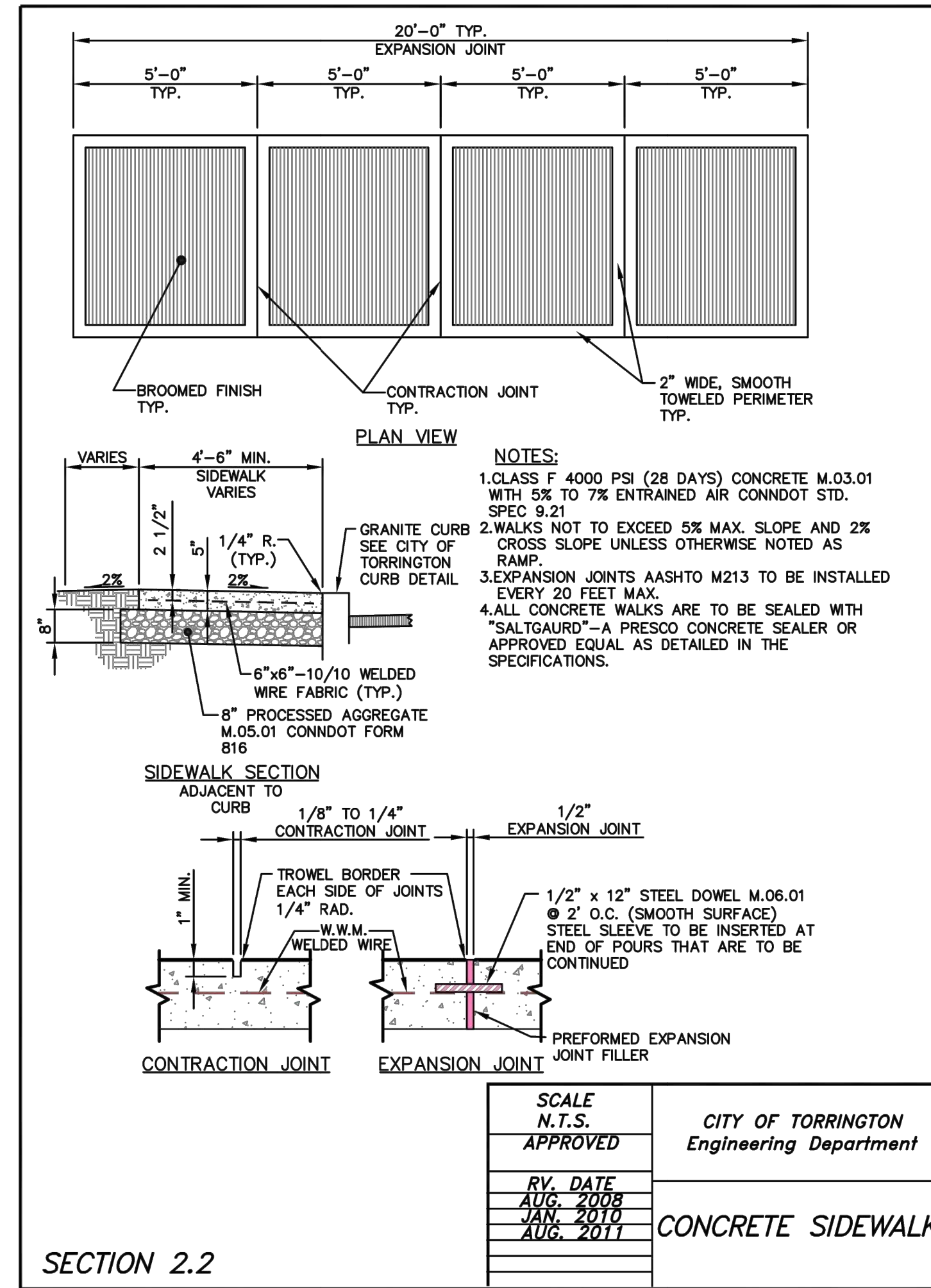

SCALE N.T.S.	CITY OF TORRINGTON Engineering Department
APPROVED	
RV. DATE AUG. 2008 JAN. 2010 AUG. 2011	CONCRETE SIDEWALK

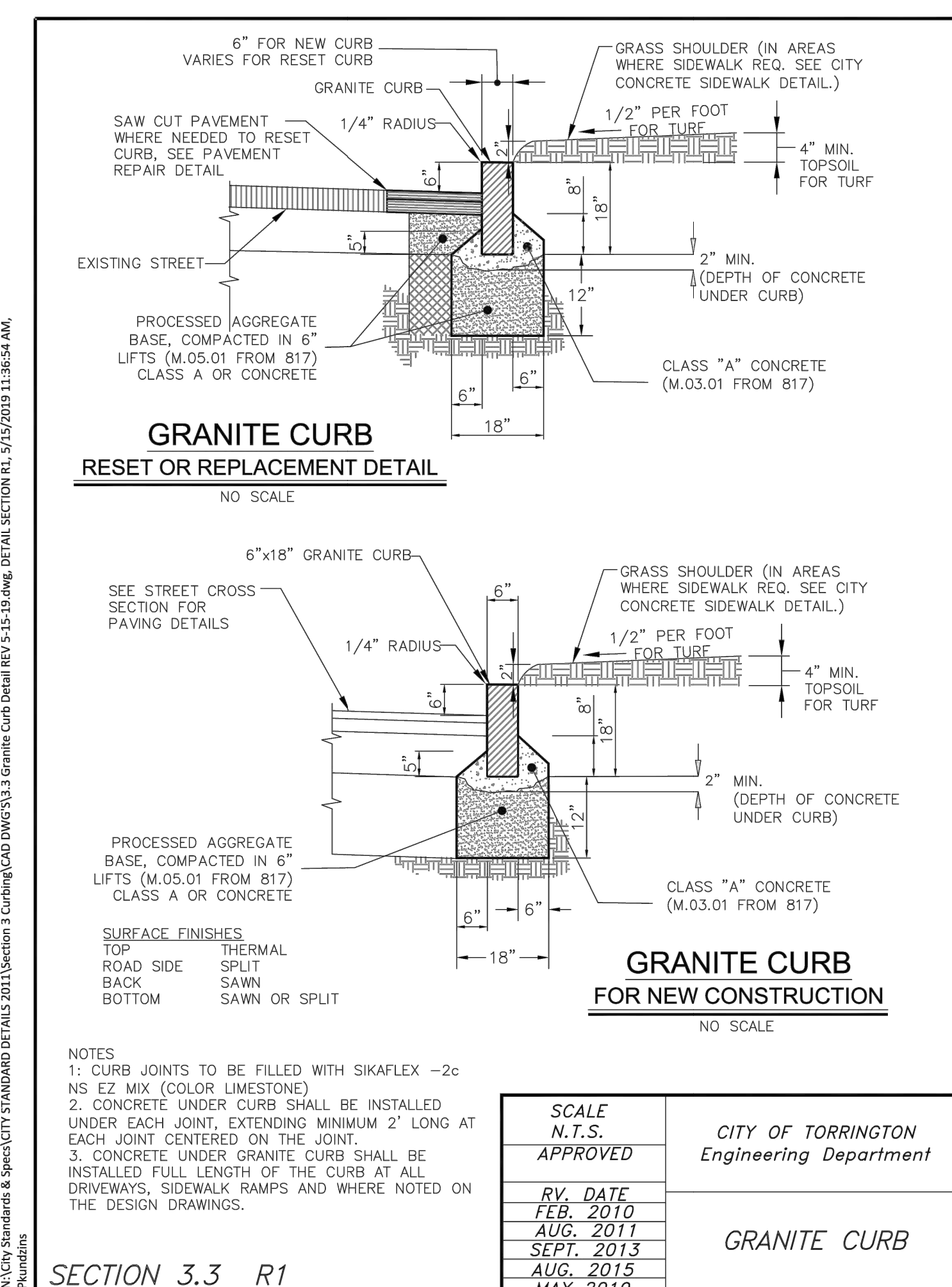

SCALE N.T.S.	CITY OF TORRINGTON Engineering Department
APPROVED	
RV. DATE FEB. 2010 AUG. 2011 SEPT. 2013 AUG. 2015 MAY 2019	GRANITE CURB

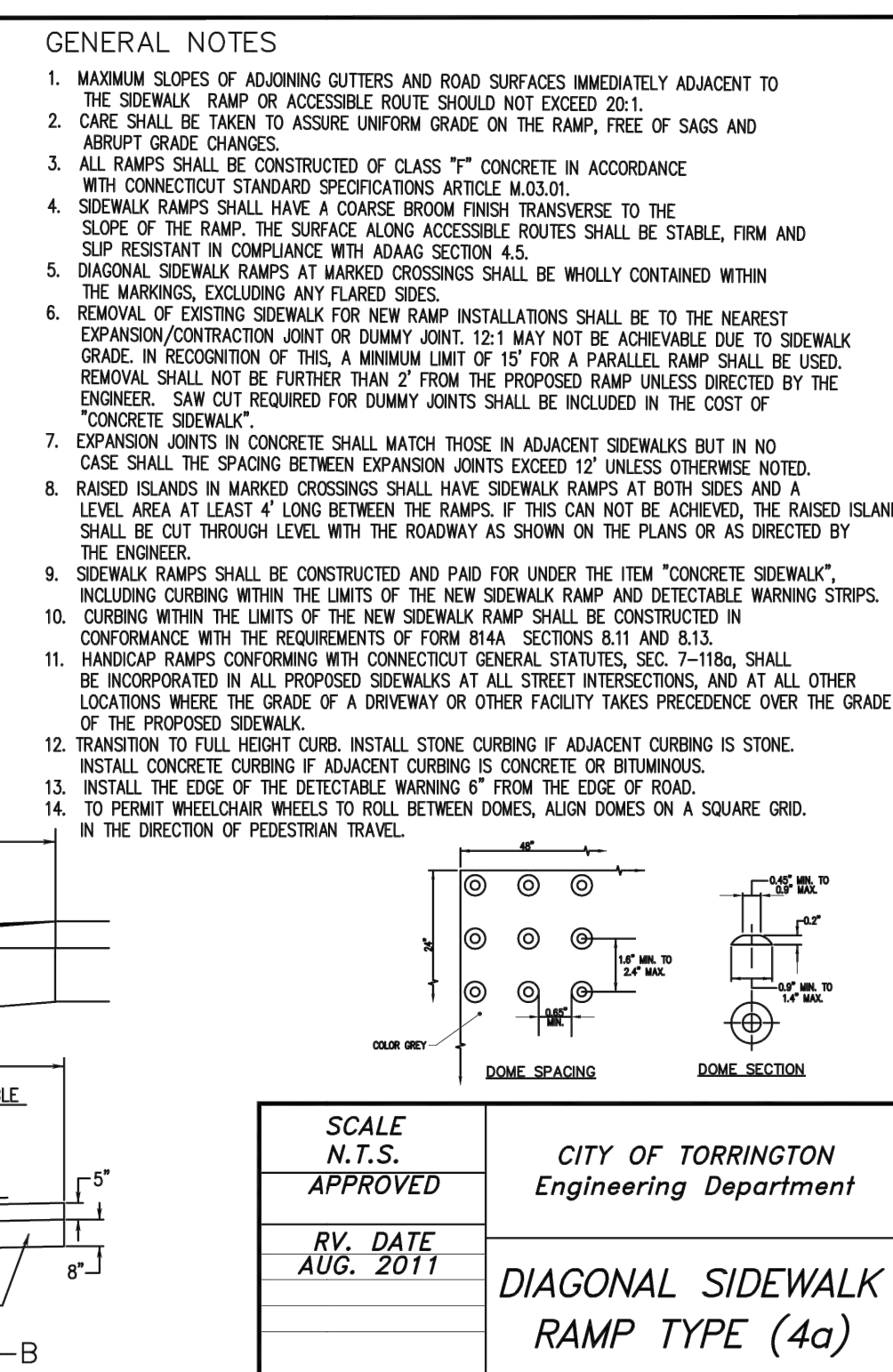
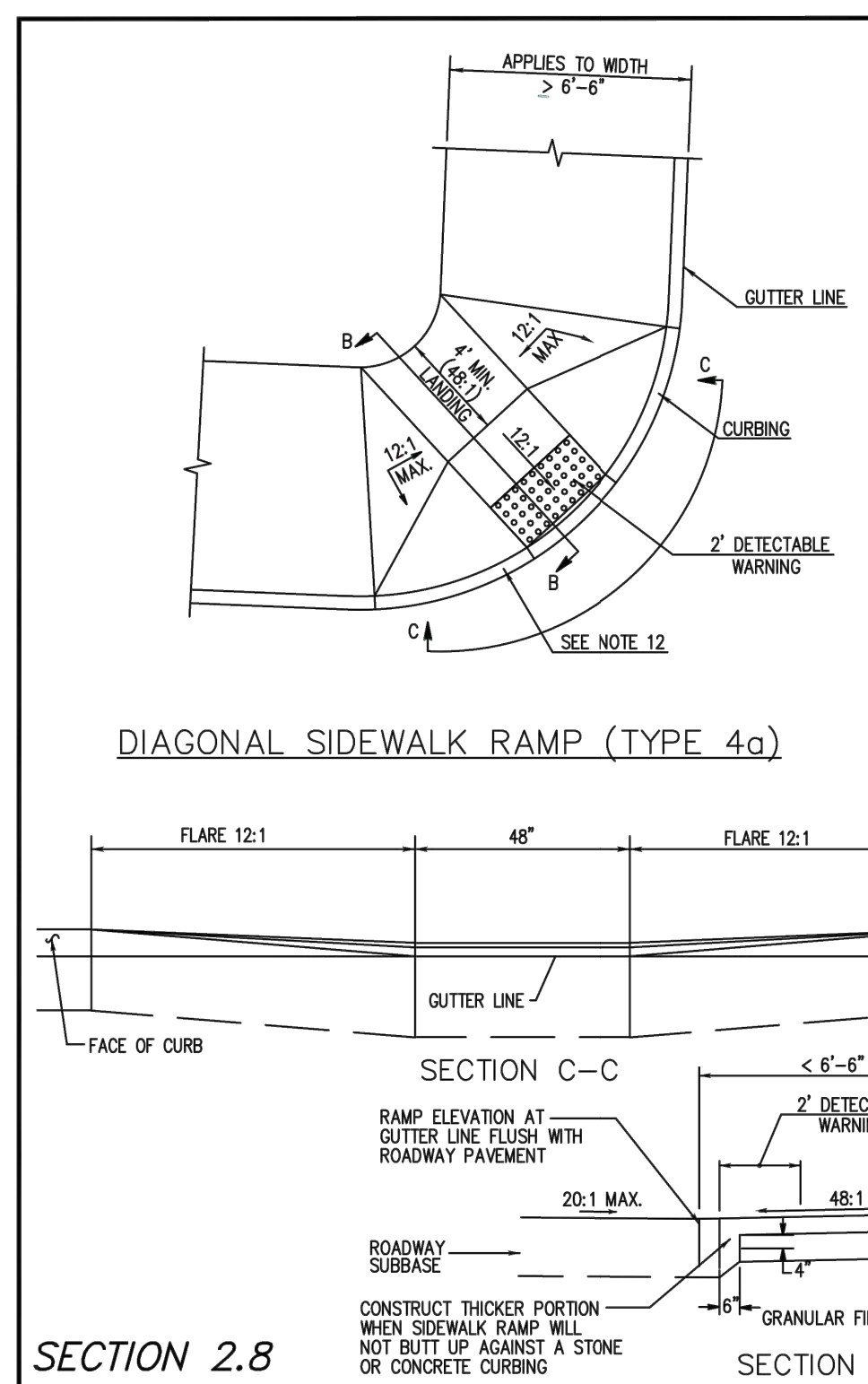

GENERAL NOTES

- MAXIMUM SLOPES OF ADJOINING GUTTERS AND ROAD SURFACES IMMEDIATELY ADJACENT TO THE SIDEWALK RAMP OR ACCESSIBLE ROUTE SHOULD NOT EXCEED 20:1.
- CARE SHALL BE TAKEN TO ASSURE UNIFORM GRADE ON THE RAMP, FREE OF SAGS AND ABRUPT GRADE CHANGES.
- ALL RAMP SHALL BE CONSTRUCTED OF CLASS 7\"/>

SCALE N.T.S.	CITY OF TORRINGTON Engineering Department
APPROVED	
RV. DATE AUG. 2011	DIAGONAL SIDEWALK RAMP TYPE (4a)

SCALE N.T.S.	CITY OF TORRINGTON Engineering Department
APPROVED	
RV. DATE AUG. 2011	PARALLEL SIDEWALK RAMP

