

CITY OF TORRINGTON



Land Use Office
Martin J. Connor, AICP, City Planner
140 Main Street • City Hall
Torrington, CT 06790-5245
E-mail: Martin_Connor@torringtonct.org

Phone: (860) 489-2221
Fax: (860) 496-5928

City of Torrington website: www.torringtonct.org

To: Planning & Zoning Commission
From: Martin J. Connor, AICP, City Planner
Date: July 14, 2021
RE: Special Exception 21-09 & Site Plan #1378, Alam Realty Inc., add gasoline dispensers, canopy, storm drainage, parking, & modifications to building facade

Alam Realty Inc. has filed a Special Exception and Site Plan application to add gasoline dispensers, canopy, storm drainage, parking, & modifications to the building facade at Sam's Mart, 861 New Harwinton Rd. The current use of the property is a retail convenience store. The Special Exception use proposed will add a new gasoline station use to the existing retail use. The proposed gasoline station is a Special Exception use in the LB Zone per Sections 3.1 Subsection 8.40 of the Zoning Regulations. The existing convenience store retail use is a permitted use per Sections 3.1 Subsection 3.10 of the Zoning Regulations. Plans submitted are titled, "Modifications and Improvements to Sam's Mart, 861 New Harwinton Road (CT RTE #4), Torrington, Connecticut," by Jason Dismukes, Consulting Engineers, dated 6/21/21, sheets, C1 - C6, EX1-2, & P1-P4. The Zoning Information Table on sheet C1 indicates that the proposed Canopy, site improvements and building façade modifications meet the required Zoning setbacks, maximum impervious surface requirements, maximum building height, and that the minimum parking requirements are all compliant. Staff has met previously to discuss the project with the applicant, project engineer and architect prior to submission.

In reviewing the application & plans and documents submitted, I have the following comments:

1. The neighbor notice sent to the adjacent property owner's office lists the wrong date of the public hearing. It lists 7/23/21, rather than 7/21/21. This requires the Commission to reschedule the public hearing due to the improper notice. The suggested date to reschedule the public hearing is 8/18/21.
2. Sheets C2-C4 need the title block street name typo corrected from "Harwinton Road" to New Harwinton Road.
3. Should the Commission approve the application this will constitute Gasoline Location Approval in accordance with Section 6.2.1.A. The property has more than 150 feet of lot frontage required for a gasoline station per Section 6.2.1.B.
4. A Lighting Plan per Sections 5.17 and 8.4.3.H. is required.
5. The Erosion and Sedimentation Control plans appear complete and eligible for certification. A bond estimate, prepared by the Project Engineer, should be submitted for the cost of the installation and maintenance of the soil erosion and sediment controls as

- shown on the approved plans. A performance bond in an amount approved by the City Planner's office and in a form acceptable to the Corporation Counsel should be submitted prior to issuance of a Zoning Permit to cover the estimated costs of the E&S measures.
6. A Stormwater Management Plan is required per Section 7.4.2 of the Regulations. A Stormwater Management Plan /Best Management Practice (BMP) Maintenance Agreement with the City of Torrington will be required and filed on the Torrington Land Records per Section 7.4.2.D of the Regulations.
 7. Information on the proposed underground fuel storage tanks should be submitted.
 8. An emergency generator sized to cover the gas station and convenience store would be a great addition to the project from an emergency management standpoint.
 9. Most new gas stations are adding electric charging stations. It would seem prudent to add charging stations to the project.

Other Staff Comments:

Architectural Review Committee: The Committee review has been rescheduled from 7/15/21 to August 5, 2021 at the applicant's request.

Building Official: Kevin Gillette reviewed the application and plans and indicated to me in a plan review dated 7/1/21: *Please see the attached Preliminary Site Plan Review. I am of the opinion that the referenced interior renovations completed without permits should be permitted, inspected and approved prior to issuance of any other permits from any Departments for additional work to be performed on the property.*

1. *During review it was noted that the interior retail portion of the building has undergone substantial renovations without the required permits and associated inspections. The complete scope of work performed without permits must be declared and the required permit applications submitted for review.*
2. *After permit issuance, the required inspections will be performed to ensure compliance with the requirements with the CT State Building Code.*
3. *Complete sets of IBC Section 107 Construction Documents will be required for the permitting process to enable the construction of the proposed gasoline dispensers, canopy, storm drainage, parking and modifications to the building façade.*

Inland Wetlands, Landscaping, Lighting & Signage: Jeremy Leifert, Assistant City Planner, CZ&WEO, reviewed the plans and indicated in his updated e-mail memo to me dated 7/14/21 indicated: *I have reviewed the information submitted for the proposed exterior site changes and proposed addition of gasoline pumps and sales at 861 New Harwinton Avenue under site plan application #1377, and offer the following comments:*

Wetlands – *A watercourse is conveyed underground adjacent to this property and is shown as a 24" concrete pipe off of the northeast property boundary. There is no proposed disturbance to the underground infrastructure conveying the watercourse. The "daylighted" areas of the watercourse near the inlet and outfall on adjacent properties are greater than 100 feet from the proposed site. Therefore, no wetlands permits are required for this application. This constitutes a favorable wetlands report for this application.*

Landscaping – The landscaping plan as proposed in the “S&E and Landscaping Plan” sheet is acceptable.

Lighting – No additional outdoor lighting appears to be proposed as part of this plan. If any new lighting is proposed related to the gas canopy or other site improvements, it should be added to the plans and a photometric plan should be included to show compliance with lighting regulations. All exterior lighting proposals shall be in accordance with the requirements of section 5.17 of the zoning regulations.

Signage – The plans call for removal of the existing free standing sign and addition of a new free standing sign in the same southwestern corner of the property. There does not appear to be a note in the plans on the proposed dimensions of the sign. Information on the dimensions and area of the free standing sign should be added to the plans. It appears that no other commercial signage is proposed as part of this application. All new signage shall be permitted in conformance with section 5.15 of the zoning regulations. Any new proposed signs of over 32 square feet will require site plan approval.

Engineering: Paul Kundzins, P.E., Deputy Public Works Director/City Engineer has marked up the plans electronically and emailed his comments on 7/13/21 to the owner, Project Engineer and myself. His written comments below need to be addressed by the applicant:

1. Proposed storm system should be kept private as much as possible. The City would prefer to have only one pipe connection to the existing CB in Circle Dr.
2. Show detailed grading for the concrete apron in front of the building and accessible parking space. (red “x” on plan need grades)
3. The angle parking on the east side spaces closest to Rte 4 will back out into the driveway entrance and may create conflicts with vehicles entering.
4. The pipe from Struct#2 into Struct#3 has many bends and is not labelled in plan
 - a. how will this pipe be cleaned out and serviced ?
 - b. What are the bends – show bends in profile.
 - c. It appears that there is clearance over the 8” pipe with the 4” from the building - please confirm clearance
 - i. show 4” crossing the 8” in the profile.
 - d. The 4” from the building crosses the corner of the oil separator – what is clearance?
5. The line type on the plan for the existing paint markings is confusing since proposed paint marking line type is similar and difficult to distinguish.
6. Plan C5 - show truck stopped at stop sign on Circle at Rte 4 does not cross CL of Circle
 - a. can cars turning into Circle Rd get passed stopped truck?
 - b. Show turning movement for truck turning both directions onto Rte 4.
7. How do the permeable pavers at the accessible space drain?
8. Does Struct#4 need to remain a CB top or can it be a MH top? – what does it catch for drainage?

WPCA: Mary Perrotti, Administrative Assistant, in an e-mail memo to me dated 7/14/21 that the WPCA had no comments on the application.

Police Traffic: Sgt. Baldis, Police Traffic Unit in an email memo to me dated 7/13/21 indicated:

"Only question is with gas pumps and more traffic did the DOT comment on any need to update the flashing light to a full blown signal? That's it from my end."

Fire: Fire Marshal Edward Bascetta in a letter to me dated 6/29/21, recommended:

- 1. The building should be equipped with a complete and compliant fire protection and alarm system compatible with the occupancy. The fact it will be vacant during non-business hours makes it a prime candidate for the delayed discovery of a fire inside.*
- 2. Torrington makes use of 'lock boxes' to allow quick access by fire fighters in time of an alarm without causing damage. A lock box should be installed on the exterior of the building near the main door. The fire department will use its secure master key to open the box, and allow the building owner to leave appropriate building access keys inside. This eliminates any delay in entering the building or waiting for a key-holder to arrive in the middle of the night.*
- 3. The building and area must comply with all required building and electrical codes, and will be inspected by the Fire Marshal for compliance with the Life Safety Code prior to the issuance of a Certificate of Occupancy, and annually thereafter.*

Conclusion: The applicant should address the Staff comments above prior to the rescheduled public hearing.

Cc: Jason Dismukes, P.E.
Michael Boe
Alam Realty

Martin J Connor

From: Paul Kundzins
Sent: Tuesday, August 17, 2021 11:12 AM
To: Jason Dismukes; Martin J Connor; 'Michael Boe'
Subject: RE: ARC Meeting 8/5
Attachments: 3.1 BITUMINOUS CONCRETE LIP CURB.pdf

Hi Jason,

Here are my comments:

1. City detail for bit curb (attached) has the curb on the base course and top course butting up against the face of curb (7.5" mold) - The City does not want to have a new sawcut joint and a bituminous concrete patch strip in the road at the face of curb. Provide a detail for installing new bituminous curb along the existing edge of Circle Drive.
2. Sheet C5 vehicle turning:
 - a. Cars from gas pumps (or anywhere from the site) cannot exit onto Circle Drive or RTE 4 on the opposite side of the entrance.
 - b. Show WB-40 stopped at the Circle Drive stop bar such that trailer is not blocking opposite side of the road.

Paul.

*Paul Kundzins, P.E.
Deputy Public Works Director – City Engineer
City of Torrington
140 Main Street
Torrington, CT 06790
860-489-2234*

 [Chat with me on Teams!](#)

From: Jason Dismukes <jason@dismukesengineering.com>
Sent: Monday, August 16, 2021 2:08 PM
To: Paul Kundzins <Paul_Kundzins@torringtonct.org>; Martin J Connor <Martin_Connor@torringtonct.org>; 'Michael Boe' <boestudio1@optimum.net>
Subject: RE: ARC Meeting 8/5

CAUTION: This email originated from outside of the organization. Do not click links or open attachments unless you recognize the sender and know the content is safe.

Paul,
See attached revised plan.
Thank you
Jason

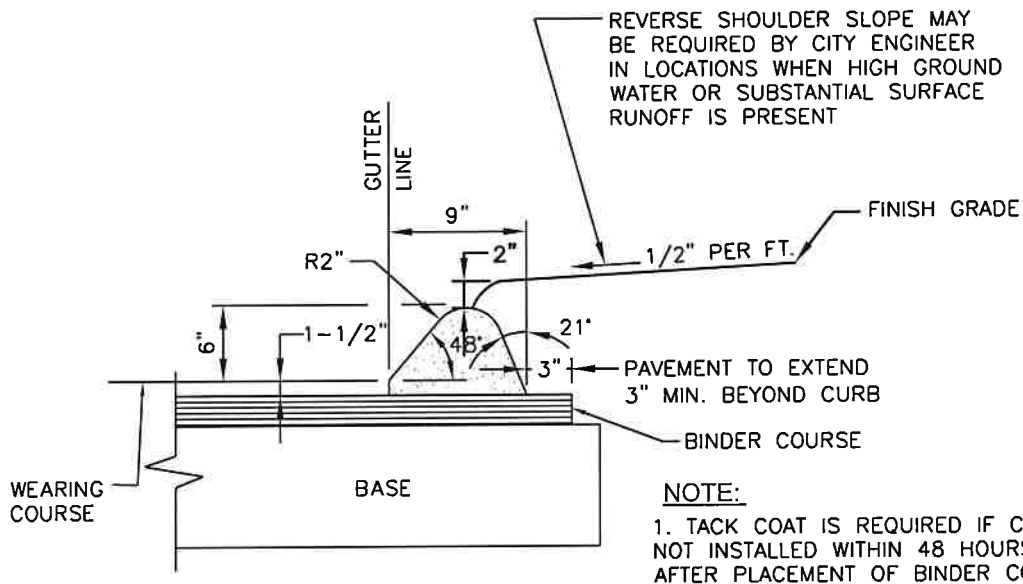

BITUMINOUS CONCRETE LIP CURB

NOT TO SCALE

SCALE N.T.S.	CITY OF TORRINGTON Engineering Department
APPROVED	
RV. DATE JAN. 2002	BITUMINOUS CONCRETE LIP CURB
DEC. 2009	
AUG. 2011	

SECTION 3.1

*City of Torrington Building Department
140 Main St. Torrington, CT 06790, (860) 489-2244
Preliminary Site Plan Review*

Date: 7/1/21

Site Address: 861 New Harwinton Road

Description of work: Add gasoline dispensers, canopy, storm drainage, parking and modifications to building façade.

Building Permit number: B21- required

Plumbing Permit number: P21- required

Mechanical Permit number: M21- required

Electrical Permit number: E21- required

Sewer Permit number: S21- required

Sign Permit number: Sign21- required

Alam RealtyInc.

PO Box 246

Harwinton, CT 06791

860-833-1224

tonymahmoodm@aol.com

- *During review it was noted that the interior retail portion of the building has undergone substantial renovations without the required permits and associated inspections. The complete scope of work performed without permits must be declared and the required permit applications submitted for review. After permit issuance, the required inspections will be performed to ensure compliance with the requirements with the CT State Building Code.*
- *Complete sets of IBC Section 107 Construction Documents will be required for the permitting process to enable the construction of the proposed gasoline dispensers, canopy, storm drainage, parking and modifications to the building façade.*

Subject to review and on-site correction.

It shall be the duty of the permit holder or their agent to notify the Building Official that such work is ready for inspection.

The approval of plans and the issuance of permits will in no manner waive the requirements for material quality or code compliance to the 2018 Connecticut State Building Codes. Field inspections are necessary and may require corrective measures for compliance with the Connecticut Building Code and City of Torrington Ordinances.