



445 Hamilton Avenue, 14th Floor  
White Plains, New York 10601  
T 914 761 1300  
F 914 761 5372  
cuddyfeder.com

Kristen Motel  
[kmotel@cuddyfeder.com](mailto:kmotel@cuddyfeder.com)

September 22, 2021

**VIA ELECTRONIC MAIL AND FEDERAL EXPRESS**

Chairman Greg Mele  
and Members of the Planning and Zoning Commission  
City of Torrington  
140 Main Street, Room 324  
Torrington, Connecticut 06790

Re: Volta Electric Vehicle Charging/Display Kiosks  
Zoning Text Amendment Application  
Premises: Stop & Shop, 931 Torrington Street, Torrington, CT 06790

Dear Chairman Mele and Members of the Planning and Zoning Commission:

This letter and enclosed materials are respectfully submitted on behalf of Volta Charging, LLC ("Volta"), in support of its Petition to amend the City of Torrington Zoning Regulations ("Zoning Regulations").

Volta respectfully proposes amendments to Sections 5.15.2, 5.15.5.B, and 5.15.6.B of the Zoning Regulations to permit accessory electric vehicle charging kiosks equipped with electronic displays in the Local Business ("LB") Zone, subject to specific bulk, design and visibility requirements.

In support of the proposed amendments, enclosed please find the following materials:

- Exhibit A:** Application to Amend the Zoning Regulations;
- Exhibit B:** Petition for Zoning Text Amendment;
- Exhibit C:** Proposed Zoning Text Amendments; and
- Exhibit D:** Site Plans prepared by Kimley-Horn, P.C. dated March 3, 2021, last revised July 21, 2021.

Also enclosed is a check made payable to the City of Torrington in the amount of \$360.00 representing the zoning amendment filing fee.

We respectfully request that this matter be placed on the Planning and Zoning Commission's next available meeting Agenda for discussion and to schedule a public hearing. Should the



September 22, 2021

Page 2

Commission or City Staff have any questions regarding the enclosed, please do not hesitate to contact us. Thank you in advance for your consideration in this regard.

Sincerely,

A handwritten signature in blue ink, appearing to read "Kristen Motel", is written over a faint, light blue horizontal line.

Kristen Motel  
Enclosures

Cc: Volta Charging, LLC  
Kimley-Horn, P.C.  
Christopher B. Fisher, Esq.  
Allison Fausner, Esq.

# Exhibit A



CITY OF TORRINGTON  
Planning & Zoning Commission

APPLICATION FOR CHANGE OF ZONING REGULATIONS

Fee: \$360 (including \$60 State tax)

**Applicant:** Samuel Lee, on behalf of Volta Charging, LLC

Address: 155 DeHaro Street, San Francisco, CA 94103

Phone: 917-903-6066 Fax: \_\_\_\_\_

E-Mail Address: samuel.lee@voltacharging.com

**Attorney or Agent:** Kristen Motel, Esq., Cuddy & Feder, LLP, Attorney for Applicant

Address: 445 Hamilton Avenue, 14th Floor, White Plains, NY 10601

Phone: 914-761-1300 Fax: 914-761-5372

E-Mail Address: kmotel@cuddyfeder.com

**Section of Regulation Proposed to be Amended or Added:**  
(State clearly the proposed amendment or attach brief to this application)

The applicant proposes to amend Zoning Regulations Sections 5.15.2, 5.15.5.B and 5.15.6.B.  
See attached Zoning Regulations Petition.  
\_\_\_\_\_  
\_\_\_\_\_  
\_\_\_\_\_  
\_\_\_\_\_  
\_\_\_\_\_  
\_\_\_\_\_

**Signature of Applicant or Agent:**  **Date:** 9/21/21

**FOR OFFICE USE ONLY**

Application Fee Paid: \_\_\_\_\_

Date of Public Hearing: \_\_\_\_\_

Date of Decision: \_\_\_\_\_

Action Taken: \_\_\_\_\_

# Exhibit B

PLANNING AND ZONING COMMISSION: CITY OF TORRINGTON  
COUNTY OF LITCHFIELD: STATE OF CONNECTICUT

-----X  
In the Matter of the Application of

**Volta Charging, LLC**

**PETITION**

Petition to the Amend the Zoning Regulations of the City of  
Torrington to Permit Electric Vehicle Charging/Display Kiosks on  
Parcels in the Local Business Zone that Will Apply to Real  
Property Located at 931 Torrington Street, Designated on the Tax  
Map of the City of Torrington as Section 144, Block 002, Lot 010  
-----X

TO THE HONORABLE CHAIRMAN AND MEMBERS OF THE PLANNING AND ZONING  
COMMISSION OF THE CITY OF TORRINGTON

The Petition of Volta Charging, LLC (“Volta” or the “Petitioner”) respectfully shows and alleges in support of Petitioner’s request:

1. **PETITIONER:** Volta Charging, LLC is a corporation organized and existing under the laws of the State of Delaware and is requesting text amendments to the Zoning Regulations of the City of Torrington (the “Zoning Regulations”) to permit EV Charging/Display Kiosks on parcels classified in the Local Business Zoning District, subject to specific bulk, design and visibility requirements.

Volta operates electric vehicle (“EV”) charging networks throughout the United States and provides free charging in convenient locations. By generating revenue through sponsored content, Volta creates value and passes that on to EV owners who can charge while they shop. This encourages consumer adoption of electric vehicles with net reductions in carbon emissions.

Volta is partnering with Stop & Shops across the Northeast to establish on-site electric vehicle charging kiosks that enhance the shift from combustion-powered miles to electric miles. The charging kiosks include a digital display feature for various sponsored content, which enables Volta to provide the vehicle charge at no cost to the driver while it is parked on-site.

2. **THE PARCEL & FUTURE PROPOSAL:** The Petitioner is proposing to install two (2) EV Charging/Display Kiosks in the parking lot of the Stop & Shop located at 931 Torrington Street (the “Parcel”) in the City of Torrington, Connecticut.

The Parcel is currently classified within the Local Business (“LB”) Zone and is situated to the west of Torrington Street (Route 183), just south of East Main Street (Route 202). The Parcel is only improved with a Stop & Shop, there are no other retail tenants at the Parcel.

Volta proposes to convert two (2) standard parking spaces into two (2) electric vehicle spaces with charging kiosks located in existing landscaped islands. The kiosks are approximately seven and a half (7.5) feet tall and three (3) feet wide and include digital displays that are four (4) feet tall and 2¼ (2.25) feet wide.

The EV Charging/Display Kiosks will be located in the first row of parking spaces, closest to the Stop & Shop building entrance to target pedestrian traffic. The kiosks are not intended for any off-site visibility and will be seen only by Stop & Shop patrons. The digital displays themselves have an auto-dimming feature and are equipped to display subtle motion with sponsored content changing at a maximum of 8-second intervals. Concept drawings and renderings of the proposed EV Charging/Display Kiosks are annexed hereto as **Exhibit D**.

3. IN FURTHERANCE OF THE CITY OF TORRINGTON'S 2019 PLAN OF CONSERVATION AND DEVELOPMENT, THE PROPOSED EV CHARGING/DISPLAY KIOSKS WILL ENHANCE SUSTAINABILITY INITIATIVES AND PROMOTE BUSINESS GROWTH: The proposed zoning text amendments will permit EV Charging/Display Kiosks in limited locations to serve and complement business areas while also promoting sustainable practices and supporting businesses development. See **Exhibit C** – Zoning Text Amendments.

The City of Torrington 2019 Plan of Conservation and Development (“2019 POCD”) identifies the objectives of adopting sustainable practices, specifically citing the need to reduce dependence upon fossil fuels, as well as supporting transportation improvements and recruiting new industry.<sup>1</sup>

The proposed zoning amendments will support transportation improvements that will guide future land-use consistent with the overall goals of the 2019 POCD.<sup>2</sup> Specifically, the installation of EV charging kiosks will enable citizens and travelers in the City of Torrington to reduce their dependence on fossil fuels thereby reducing emissions.<sup>3</sup> As a member of the Connecticut Clean Energy Community Program, Torrington strives to promote clean renewable energy by reviewing its regulations to eliminate restrictions on the use of green energy.<sup>4</sup> The proposed amendments are integral to encouraging the adoption of clean energy transportation options by Torrington’s citizens and visitors.

In addition to the promotion of sustainability objectives, kiosks permitted under the proposed zoning amendment will promote economic growth and a supportive business environment by enhancing the City’s tax base and recruiting new industry within appropriate business areas, such as the one the Torrington Stop & Shop is classified within.<sup>5</sup> Moreover, the proposed zoning amendments include criterion specifically designed to ensure that EV Charging/Display Kiosks will be compatible with surrounding land uses.

Thus, amending the Zoning Regulations to permit EV Charging/Display Kiosks in business areas furthers Torrington’s goals of fostering sustainability initiatives and promoting economic growth.

WHEREFORE, the Petitioner respectfully requests that this Petition be granted in its entirety thereby amending the Zoning Regulations of the City of Torrington to permit EV

---

<sup>1</sup> See 2019 POCD 12-1, 13-1, 8-3, 8-14.

<sup>2</sup> See 2019 POCD 12-1.

<sup>3</sup> See 2019 POCD 13-1.

<sup>4</sup> See 2019 POCD 13-2.

<sup>5</sup> See 2019 POCD 8-2, 8-3.

Charging/Display Kiosks on parcels classified in the LB Zone subject to specific bulk, design and visibility requirements.

Dated: September 22, 2021

Respectfully submitted,

A handwritten signature in blue ink, appearing to read "Kristen Motel", written over a horizontal line.

Kristen Motel  
**Cuddy & Feder LLP**  
Attorneys for Petitioners  
445 Hamilton Avenue, 14<sup>th</sup> Floor  
White Plains, New York 10601



# Exhibit C

**Exhibit A:**

**Proposed Zoning Text Amendment**

Section 5.15.2 of the Zoning Regulations is amended to add the following definition:

“EV Charging/Display Kiosk – A combined electric vehicle charging kiosk with internally illuminated LED displays. EV charging/display kiosks must meet the following criteria:

1. There shall be a maximum of two EV Charging/Display Kiosks per business or business location.
2. EV Charging/Display Kiosks shall not exceed 21.5 square feet in size and 7.5 feet in height.
3. EV Charging/ Display Kiosks display screen shall not exceed 9 square feet.
4. EV Charging/Display Kiosks shall be equipped with an auto-dimming feature.
5. EV Charging/Display Kiosks shall limit content refresh rates to no more than every 8 seconds.
6. EV Charging/Display Kiosks shall be located within 100 feet of the front façade of the business building on the site.
7. EV Charging/Display Kiosks shall be located within a parking lot serving only one retail store with a building footprint of no less than 57,000 square feet.
8. Any EV Charging/Display Kiosks not meeting the requirements of subsections 1 through 7 of this subsection shall be deemed a prohibited Off-Premise Sign pursuant to Section 5.15.2 of these Zoning Regulations.

Section 5.15.2 of the Zoning Regulations is amended as follows (revisions indicated by underline):

Off-Premise Sign – A sign which directs attention to a business, commodity, service or activity conducted, sold, offered or held at a location other than the lot on which the sign is located. A ‘billboard’ is an example of an off-premise sign. An EV Charging/Display Kiosk does not constitute an Off-Premise Sign.

Section 5.15.5.B and Table 1 of the Zoning Regulations is amended to add the following:

- A row for “EV Charging/Display Kiosk” permitting EV Charging/Display Kiosks as a zoning permit use (“S”) in the Local Business (“LB”) Zoning District (see below).

**Table 1** – Signs by Type in All Zoning Districts

<b>Sign Type</b>	<b>DD</b>	<b>LB</b>	<b>I</b>	<b>IP</b>	<b>CIR</b>	<b>Residential</b>
Banner	S	S	S	S	S	N
Billboard	N	N	N	N	N	N
Canopy	S	S	S	S	S	N
Construction	S	S	S	S	S	S
<u>EV Charging/Display Kiosks</u>	<u>N</u>	<u>S</u>	<u>N</u>	<u>N</u>	<u>N</u>	<u>N</u>
Farm Directional	P	P	P	P	P	P
Flag	P	P	P	P	P	P
Free-Standing	S	S	S	S	S	S
Home Occupation	S	S	S	N	N	S

Incidental	P	P	P	P	P	N
Lamp Post Banner	P	P	N	N	N	N
Marquee	S	S	N	N	S	N
Off-Premise	N	N	N	N	N	N
Pennant	N	N	N	N	N	N
Portable Sign	S	S	N	N	S	N
Projecting Sign	S	S	N	N	N	N
Rear Entrance Sign	S	S	S	N	S	N
Residential	P	P	P	N	N	P
Residential Development Sign	N	N	N	N	N	S
Roof Sign	S	S	S	S	S	N
Temporary Sign	S	S	S	N	N	S
Wall Sign	S	S	S	N	N	S
Window Sign	P	P	P	P	P	N

- S = allowed with Zoning Permit
- P = allowed by right, no Zoning Permit required
- E = allowed by Special Exception approval
- N = not allowed

Section 5.15.6.B of the Zoning Regulations is amended as follows (revisions indicated by underline):

5.15.6 Sign Illumination B. No sign may contain or be illuminated by flashing or intermittent lights or lights of changing degrees of intensity except for signs that indicate time, date and temperature or gasoline sales prices or EV Charging/ Display Kiosks. With the exception of EV Charging/Display Kiosks, LED or electronic changeable signs are not permitted.

# Exhibit D

# VOLTA

## STOP & SHOP #2604 TORRINGTON

931 TORRINGFORD STREET  
TORRINGTON, CT 06790  
LITCHFIELD COUNTY

# VOLTA

155 DE HARO STREET  
SAN FRANCISCO, CA 94103

# Kimley»Horn

1 N LEXINGTON AVE, SUITE 505  
WHITE PLAINS, NY 10601  
Main: 914.368.9200 | www.kimley-horn.com  
© 2021 Kimley-Horn and Associates, Inc.

ITEM	TASK	YES	NO	N/A
1	CONTACT 811 UTILITY PRIOR TO EXCAVATION WORK.			
2	NOTIFY VOLTA & KIMLEY-HORN OF ANY DISCREPANCIES W/ PLANS OR POTENTIAL CONFLICTS.			
3	VERIFY ALL FIELD CONDITIONS PRIOR TO START OF CONSTRUCTION IN ACCORDANCE WITH THESE PLANS.			
4	INSTALL WORK AREA PROTECTION MEASURES.			
5	FIELD LOCATE EXISTING UTILITIES AND CROSSINGS & VERIFY NO CONFLICTS W/PROPOSED INFRASTRUCTURE.			
6	FIELD VERIFY ALL STALL DIMENSIONS AND EQUIPMENT LOCATIONS.			
7	CONFIRM ALL ADA AND LOCAL REQUIREMENTS ARE MET.			
8	ESTABLISH TEMPORARY CONSTRUCTION ACCESS(ES).			
9	IMPLEMENT AND MAINTAIN EPSC CONTROL MEASURES PER LOCAL REQUIREMENTS.			
10	LOCATE VERTICAL AND HORIZONTAL UTILITIES PRIOR TO BORING.			
11	PROVIDE PROPOSED LIMITS OF ASPHALT OVERLAY SKETCH TO KIMLEY-HORN & VOLTA (IF NEEDED).			
12	SEED & STABILIZE ALL DISTURBED AREAS AFTER FINAL GRADING.			

ALL WORK AND MATERIALS SHALL BE PERFORMED AND INSTALLED IN ACCORDANCE WITH THE CURRENT EDITIONS OF THE BUILDING/DWELLING, STRUCTURAL, PLUMBING, MECHANICAL, ELECTRICAL, AND FIRE/LIFE SAFETY CODES AS ADOPTED BY THE LOCAL GOVERNING AUTHORITIES. NOTHING IN THESE PLANS IS TO BE CONSTRUCTED TO PERMIT WORK NOT CONFORMING TO THE LOCAL GOVERNING AUTHORITIES CODES.

**VOLTA PROPOSES:**

- (2) STANDARD PARKING SPACE(S) IS/ARE TO BE CONVERTED INTO (2) STANDARD ELECTRIC VEHICLE (EV) PARKING SPACE(S). (2) ELECTRIC VEHICLE CHARGING STATION(S) IS/ARE TO BE INSTALLED IN A (STRIPED/LANDSCAPE ISLAND(S)) ADJACENT TO THE EV PARKING STALL(S). ELECTRICAL CONDUITS WILL BE EXTENDED FROM THE EXISTING BUILDING TO THE ELECTRIC VEHICLE CHARGING STATION. VOLTA WILL ALSO PAINT AND MARK ALL EV CHARGING PARKING SPACES AND INSTALL NECESSARY PARKING SIGNS.

**APPLICANT:**

VOLTA  
155 DE HARO STREET  
SAN FRANCISCO, CA 94103  
CONTACT: EVA ABENIACAR  
PHONE: (610)-570-9756  
EMAIL: EVA.ABENIACAR@VOLTACHARGING.COM

**SITE PARTNER:**

STOP AND SHOP  
1385 HANCOCK ST  
QUINCY, MA 02169  
CONTACT: LINDA CAMARA  
PHONE: (508)-654-6851  
EMAIL: LCAMARA@STOPANDSHOP.COM

**PROGRAM MANAGER:**

KIMLEY-HORN & ASSOCIATES  
1 N LEXINGTON AVE, SUITE 505  
WHITE PLAINS, NY 10601  
CONTACT: RYAN GRAM  
PHONE: (615)-564-2865  
EMAIL: RYAN.GRAM@KIMLEY-HORN.COM

**CIVIL ENGINEER:**

KIMLEY-HORN & ASSOCIATES  
1 N LEXINGTON AVE, SUITE 505  
WHITE PLAINS, NY 10601  
CONTACT: MIKE JUNGHANS  
PHONE: (914)-368-9189  
EMAIL: MIKE.JUNGHANS@KIMLEY-HORN.COM

**ELECTRICAL ENGINEER:**

KIMLEY-HORN & ASSOCIATES  
1 N LEXINGTON AVE, SUITE 505  
WHITE PLAINS, NY 10601  
CONTACT: JEFFREY SALLEE  
PHONE: (757)-213-8635  
EMAIL: JEFFREY.SALLEE@KIMLEY-HORN.COM

REV	DATE	DESCRIPTION	BY
1	03/03/2021	CD90s	TAS
2	05/05/2021	CD100s	TAS
3	07/21/2021	CD100s	TAS

ISSUE DATE

**05/05/2021**

ISSUED FOR

**PERMIT**

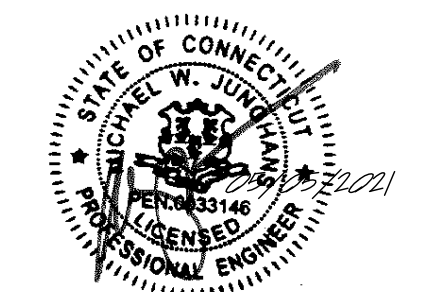

IT IS A VIOLATION OF LAW FOR ANY PERSON, UNLESS THEY ARE ACTING UNDER THE DIRECTION OF A LICENSED PROFESSIONAL ENGINEER, TO ALTER THIS DOCUMENT.

**STOP & SHOP #2604  
TORRINGTON**

**931 TORRINGFORD STREET  
TORRINGTON, CT 06790**

SHEET TITLE

**COVER SHEET**

SHEET NUMBER

**C0-00**

**CONTRACTOR VERIFICATION CHECKLIST**

**CODE BLOCK**

**PROJECT DESCRIPTION**

**PROJECT TEAM**



VICINITY MAP



LOCAL MAP

Sheet Number	Sheet Title
C0-00	COVER SHEET
C0-01	GENERAL NOTES
C0-02	VOLTA STATION OVERVIEW
C1-00	OVERALL SITE PLAN
C2-00	ENLARGED SITE PLAN
C3-00	SITE DETAILS
C3-01	SITE DETAILS
C3-02	SITE DETAILS
C3-03	SITE DETAILS
E1-00	ELECTRICAL ONE LINE DIAGRAM & PANEL SCHEDULE
E2-00	ELECTRICAL NOTES & DETAILS

**SHEET INDEX**



**DIG ALERT**

Know what's BELOW.  
CALL before you dig.

CALL AT LEAST TWO WORKING  
DAYS BEFORE YOU DIG

CONTRACTOR SHALL VERIFY ALL PLANS & EXISTING LOCATIONS, CONDITIONS ON THE JOB SITE & SHALL IMMEDIATELY NOTIFY THE ENGINEER IN WRITING OF ANY DISCREPANCIES BEFORE PROCEEDING WITH THE WORK OR BE RESPONSIBLE FOR SAME

**CALL BEFORE YOU DIG**

NOTE: THE ORIGINAL SIZE OF THIS PLAN IS 24" X 36". SCALE RATIO IS NOT VALID FOR REDUCED OR ENLARGED SHEET SIZES

**GENERAL NOTES:**

- VOLTA WILL PROVIDE AN INSTALLATION GUIDE AND OTHER SUPPORTING DOCUMENTS AT TIME OF CONSTRUCTION.
- ALL EXISTING CONDITIONS SHOWN ARE APPROXIMATE. EXISTING UTILITY LOCATIONS AND CROSSINGS ARE TO BE LOCATED IN THE FIELD. CONTRACTOR IS TO CONTACT 811 UTILITY PRIOR TO BEGINNING ANY EXCAVATION WORK.
- ALL PAVEMENT, LANDSCAPING, UTILITIES, AND OWNER PROPERTY THAT IS DAMAGED OR AFFECTED BY CONSTRUCTION SHALL BE RETURNED TO EXISTING CONDITIONS OR BETTER AT THE CONTRACTOR'S EXPENSE.
- PROPOSED PAVEMENT STRIPING SHALL LINE UP WITH EXISTING STRIPING WHEREVER POSSIBLE. ADDITIONAL PAVEMENT STRIPE IS NOT NECESSARILY PARALLEL TO THE CONSTRUCTED CHARGING ISLAND.
- THIS ACCESSIBILITY REVIEW WAS UNDERTAKEN TO IDENTIFY DESIGN FEATURES OF THE PROJECT THAT MAY BE CONSIDERED BY GOVERNMENTAL AGENCIES OR DEPARTMENTS, OR NON-GOVERNMENTAL GROUPS TO BE NON-COMPLIANT WITH THE AMERICANS WITH DISABILITIES ACT OF 1990, REVISED 2010 ADA REGULATIONS AND STANDARDS. THE AMERICANS WITH DISABILITIES ACT OF 1990 IS A FEDERAL CIVIL RIGHTS LAW. THERE IS NO FEDERAL REVIEW PROCESS TO ENSURE FULL COMPLIANCE WITH THE GUIDELINES, EXCEPT THROUGH THE FEDERAL COURT SYSTEM. THE DEPICTIONS, NOTES, AND RECOMMENDATIONS, EXPRESSED ON THIS PLAN ARE BASED ON PROFESSIONAL JUDGEMENT GAINED FROM PAST EXPERIENCE WITH ACCESSIBILITY LAWS, CODES, AND STANDARDS AND THE WORKING INVOLVEMENT TO DEVELOP ACCESSIBILITY STANDARDS THAT WILL MEET OR EXCEED THE APPLICABLE FEDERAL GUIDELINES. ACCORDINGLY, NO CLAIMS OR WARRANTIES, EXPRESSED OR IMPLIED, ARE MADE THAT IN PREPARING THIS PLAN AND PROPOSING RECOMMENDATIONS, THAT ALL POSSIBLE BARRIERS TO ALL PEOPLE HAVE BEEN IDENTIFIED.
- CONTRACTOR SHALL ACHIEVE A MINIMUM OF 1% BUT NO MORE THAN A 2% SLOPE IN ANY DIRECTION WITHIN ADJACENT ACCESSIBLE SPACE AND BLEND ASPHALT OVERLAY TO EXISTING GRADES AS REQUIRED. CONTRACTOR SHALL PROVIDE A SKETCH TO VOLTA OF PROPOSED LIMITS OF ASPHALT OVERLAY TO ACHIEVE THIS REQUIREMENT PRIOR TO BEGINNING PAVEMENT WORK.
- ACCESSIBLE EV STALLS WERE DESIGNED BASED ON EXISTING CONDITIONS AND WITHOUT THE BENEFIT OF SURVEY DATA. ALL ADA AND LOCAL REQUIREMENTS INCLUDING BUT NOT LIMITED TO SLOPE AND SPACING SHALL BE CONFIRMED BY THE CONTRACTOR AND MET AT THE TIME OF CONSTRUCTION.
- CONTRACTOR TO NOTIFY THE ENGINEER OF ANY DISCREPANCIES IN ACCESSIBILITY PRIOR TO CONSTRUCTION.
- UNDER NO CIRCUMSTANCE IS THE CONTRACTOR TO DISRUPT ANY OPERATIONS AT THE SITE HOST LOCATION, INCLUDING BUT NOT LIMITED TO CUSTOMER DISRUPTION, UTILITIES, AND INFRASTRUCTURE.
- CONTRACTOR SHALL BE RESPONSIBLE TO PROTECT WORK AREAS WITH CONES AND/OR BARRICADES AT ALL TIMES.

**EROSION CONTROL & GRADING NOTES:**

- ADDITIONAL EROSION CONTROL DEVICES TO BE USED AS REQUIRED BY LOCAL INSPECTOR.
- DISTURBED AREAS LEFT IDLE FOR FIVE DAYS, AND NOT TO FINAL GRADE, WILL BE ESTABLISHED TO TEMPORARY VEGETATION. MULCH, TEMPORARY VEGETATION OR PERMANENT VEGETATION SHALL BE COMPLETED ON ALL EXPOSED AREAS WITHIN 14 DAYS AFTER DISTURBANCE. ALL AREAS TO FINAL GRADE WILL BE ESTABLISHED TO PERMANENT VEGETATION UPON COMPLETION.
- WHEN HAND PLANTING, MULCH (HAY OR STRAW) SHOULD BE UNIFORMLY SPREAD OVER SEEDING AREA WITHIN 24 HOURS OF SEEDING. IF UNABLE TO ACCOMPLISH, MULCH SHALL BE USED AS A TEMPORARY COVER. CONCENTRATED FLOW AREAS AND ALL SLOPES STEEPER THAN 2.5:1 AND WITH A HEIGHT OF TEN FEET OR GREATER (DOES NOT APPLY TO RETAINING WALLS), AND CUTS AND FILLS WITHIN BUFFERS, SHALL BE STABILIZED WITH THE APPROPRIATE EROSION CONTROL MATTING OR BLANKETS.
- THE ESCAPE OF SEDIMENT FROM THE SITE SHALL BE PREVENTED BY THE INSTALLATION OF EROSION AND SEDIMENT CONTROL MEASURES AND PRACTICES PRIOR TO, OR CONCURRENT WITH, LAND-DISTURBING ACTIVITIES.
- EROSION CONTROL MEASURES WILL BE MAINTAINED AT ALL TIMES. IF FULL IMPLEMENTATION OF THE PLAN DOES NOT PROVIDE FOR EFFECTIVE EROSION CONTROL, ADDITIONAL EROSION CONTROL AND SEDIMENT CONTROL MEASURES SHALL BE IMPLEMENTED TO CONTROL OR TREAT THE SEDIMENT SOURCE.
- SEED ALL DISTURBED AREAS UNLESS OTHERWISE NOTED AS PART OF THIS CONTRACT.
- THE CONTRACTOR SHALL DETERMINE THE EXACT LOCATION OF ALL EXISTING UTILITIES BEFORE COMMENCING WORK AND AGREES TO BE RESPONSIBLE FOR ANY AND ALL DAMAGES WHICH MIGHT RESULT FROM THE CONTRACTOR'S FAILURE TO EXACTLY LOCATE AND PRESERVE ANY UNDERGROUND UTILITIES TO REMAIN. THE CONTRACTOR IS TO NOTIFY ENGINEER IMMEDIATELY OF ANY DISCREPANCIES AND/OR CONFLICTS WITH EXISTING OR PROPOSED UTILITIES PRIOR TO PROCEEDING.
- STOCKPILED TOPSOIL OR FILL MATERIAL IS TO BE TREATED SO THE SEDIMENT RUN-OFF WILL NOT CONTAMINATE SURROUNDING AREAS OR ENTER NEARBY STREAMS. STOCK PILE LOCATIONS SHALL BE COORDINATED WITH THE ENGINEER PRIOR TO GRADING ACTIVITIES. EROSION & SEDIMENT CONTROL PRACTICES SHALL BE INSTALLED PRIOR TO STOCKPILE OPERATIONS.
- CONSTRUCT SILT BARRIERS BEFORE BEGINNING GRADING OPERATIONS.
- MULCH AND SEED ALL DISTURBED AREAS AS SOON AS POSSIBLE AFTER FINAL GRADING IS COMPLETED (WITHIN 15 DAYS OF ACHIEVED FINAL GRADES) UNLESS OTHERWISE INDICATED. CONTRACTOR SHALL TAKE WHATEVER MEANS NECESSARY TO ESTABLISH PERMANENT SOIL STABILIZATION. STEEP SLOPES (GREATER THAN 3:1) SHALL BE STABILIZED WITHIN 7 DAYS OF FINAL GRADING.
- PROVIDE TEMPORARY CONSTRUCTION ACCESS(ES) AT THE POINT(S) WHERE CONSTRUCTION VEHICLES EXIT THE CONSTRUCTION AREA. MAINTAIN PUBLIC ROADWAYS FREE OF TRACKED MUD AND DIRT.
- DO NOT DISTURB VEGETATION OR REMOVE TREES EXCEPT WHEN NECESSARY FOR GRADING PURPOSES.

**ADA COMPLIANCE:**

- CURB RAMPS ALONG PUBLIC STREETS AND IN THE PUBLIC RIGHT-OF-WAY SHALL BE CONSTRUCTED BASED ON THE CITY STANDARD CONSTRUCTION DETAILS AND SPECIFICATIONS.
- PRIVATE CURB RAMPS ON THE SITE (I.E. OUTSIDE PUBLIC STREET RIGHT-OF-WAY) SHALL CONFORM TO ADA STANDARDS AND SHALL HAVE A DETECTABLE WARNING SURFACE THAT IS FULL WIDTH AND FULL DEPTH OF THE CURB RAMP, NOT INCLUDING FLARES.
- ALL ACCESSIBLE ROUTES, GENERAL SITE AND BUILDING ELEMENTS, RAMPS, CURB RAMPS, STRIPING, AND PAVEMENT MARKINGS SHALL CONFORM TO ADA STANDARDS FOR ACCESSIBLE DESIGN, LATEST EDITION.
- BEFORE PLACING PAVEMENT, CONTRACTOR SHALL VERIFY THAT SUITABLE ACCESSIBLE PEDESTRIAN ROUTES (PER ADA AND FHA) EXIST TO AND FROM EVERY DOOR AND ALONG SIDEWALKS, ACCESSIBLE PARKING SPACES, ACCESS AISLES, AND ACCESSIBLE ROUTES. IN NO CASE SHALL AN ACCESSIBLE RAMP SLOPE EXCEED 1 VERTICAL TO 12 HORIZONTAL. IN NO CASE SHALL SIDEWALK CROSS SLOPE EXCEED 2.0 PERCENT. IN NO CASE SHALL LONGITUDINAL SIDEWALK SLOPE EXCEED 5.0 PERCENT. ACCESSIBLE PARKING SPACES AND ACCESS AISLES SHALL NOT EXCEED 2.0 PERCENT SLOPE IN ANY DIRECTION.
- CONTRACTOR SHALL TAKE FIELD SLOPE MEASUREMENTS ON FINISHED SUBGRADE AND FORM BOARDS PRIOR TO PLACING PAVEMENT TO VERIFY THAT ADA SLOPE REQUIREMENTS ARE PROVIDED. CONTRACTOR SHALL CONTACT ENGINEER PRIOR TO PAVING IF ANY EXCESSIVE SLOPES ARE ENCOUNTERED. NO CONTRACTOR CHANGE ORDERS WILL BE ACCEPTED FOR ADA SLOPE COMPLIANCE ISSUES.

**SITE NOTES:**

- HORIZONTAL DIRECTIONAL DRILLING (HDD) OR OTHER TRENCHLESS METHODS AS APPROVED BY SITE HOST ARE THE PREFERRED METHOD TO INSTALL CONDUIT BENEATH EXISTING PARKING LOTS AND PAVED AREAS.
  - CONDUIT SHALL BE INSTALLED AT A MINIMUM DEPTH OF TWO AND ONE-HALF FEET (2.5') OR BELOW THE FREEZE LINE, WHICHEVER IS DEEPER. CONDUIT TYPE AND DESIGN TO BE SPECIFIED BY EV CHARGING STATION VENDOR AND MEET ALL LOCAL REQUIREMENTS. CONDUIT DIAMETER SHALL BE NO LARGER THAN TWO (2) INCHES.
  - THE RECEIVING PIT SHALL BE LOCATED AS CLOSE AS REASONABLY POSSIBLE TO THE PROPOSED WALL PENETRATION TO LIMIT THE LENGTH OF BUILDING-MOUNTED CONDUIT. LOCATE RECEIVING PIT WITHIN ASPHALT PAVED AREA OR CONCRETE SIDEWALK AREA; RECEIVING PIT SHALL NOT BE LOCATED WITHIN THE UNLOADING PAD [SIX TO TEN INCH (6-10") REINFORCED CONCRETE SLAB AT THE REAR OF THE STORE]. RECEIVING PIT LOCATION AND WORK AREA SHALL NOT AFFECT SITE HOST CUSTOMER OR DELIVERY TRAFFIC. SEE SUPPLEMENTAL DOCUMENTS, RECEIVING AREA DIAGRAM.
  - THE RECEIVING PIT SIZE SHALL BE LIMITED TO THREE FEET (3') BY THREE FEET (3') AND SHALL NOT UNDERMINE THE BUILDING FOUNDATION, ENCLOSURES OR CONCRETE UNLOADING PAD.
  - BACKFILL EXCAVATIONS AND REPAIR PAVEMENT PER SPECIFICATIONS BELOW.
  - WHERE CONCRETE PAVEMENT, SIDEWALK, ASPHALT PAVEMENT, CURBING, OR CURBING GUTTER IS REMOVED, THE WIDTH OF THE REMOVAL SHALL EXCEED THE ACTUAL WIDTH AT THE TOP OF THE TRENCH BY TWELVE INCHES (12") ON EACH SIDE OF THE TRENCH, OR A TOTAL OF TWO FEET (2') WIDER THAN THE TRENCH.
  - TRENCHING THROUGH THE CONCRETE RECEIVING PAD AT THE REAR OF THE STORE OR THE DRIVE-THRU SLAB IS NOT ALLOWED. ONLY TRENCHING THROUGH MINOR CONCRETE INSTALLATIONS SUCH AS SIDEWALKS WILL BE PERMITTED.
  - EXCAVATE TRENCHES TO A DEPTH FOUR INCHES (4") DEEPER THAN BOTTOM OF FINISHED PIPE ELEVATION.
  - THE BOTTOM WIDTH OF THE TRENCH SHALL BE AS REQUIRED TO PERMIT CONDUIT TO BE PROPERLY LAIN AND BACKFILL TO BE PLACED AND PROPERLY COMPACTED.
  - REMOVED PAVEMENT, CONCRETE AND EXCAVATED MATERIALS UNSUITABLE FOR USE AS BACKFILL SHALL BE DISPOSED OFFSITE.
  - BEDDING AND BACKFILL MAY BE MATERIAL EXCAVATED FROM THE TRENCH PROVIDED THAT IT IS FREE FROM DEBRIS AND ROCKS LARGER THAN ONE AND ONE-HALF INCHES (1-1/2").
  - OVER THE PIPE, IN LAYERS NOT EXCEEDING FOUR INCHES (4"), PLACE AND COMPACT SUITABLE FILL MATERIAL TO NINETY-FIVE PERCENT (95%) DRY DENSITY AS DETERMINED BY ASTM D698.
  - COMPACTING EQUIPMENT SHALL BE OF SUCH DESIGN, WEIGHT, AND QUALITY AS IS REQUIRED TO OBTAIN THE DENSITIES SPECIFIED HEREIN OR INDICATED ON THE DESIGN DRAWINGS. AREAS INACCESSIBLE TO SELF-PROPELLED COMPACTING EQUIPMENT SHALL BE COMPACTED OR CONSOLIDATED BY HAND-OPERATED MECHANICAL TAMPERS OR VIBRATORS.
  - RESTORE GRASS, LANDSCAPING, IRRIGATION AND ALL FEATURES TO THEIR PRECONSTRUCTION CONDITION.
- ANY UTILITIES, PAVEMENT, IRRIGATION, LANDSCAPING OR OTHER SITE FEATURES DAMAGED DURING CONSTRUCTION SHALL BE REPAIRED BY EV CHARGING STATION VENDOR TO SITE HOST SPECIFICATION.
  - WHERE LANDSCAPING IS IMPACTED, IT IS THE RESPONSIBILITY OF EV CHARGING STATION VENDOR TO REPOSITION OR PROVIDE NEW LANDSCAPING WITHIN THE SITE HOST PROPERTY TO ENSURE COMPLIANCE WITH ANY CODE REQUIREMENTS.
  - WHERE PARKING LOT, SIDEWALK OR OTHER PAVED AREAS ARE IMPACTED OR DAMAGED, IT IS THE RESPONSIBILITY OF THE EV CHARGING STATION VENDOR TO REPAIR THE AREA TO LIKE NEW CONDITION, REPAIR SHOULD EXTEND BEYOND DAMAGED AREA TO NEAREST CLEAR BREAK THAT ALIGNS WITH ARCHITECTURAL BREAKS, MATERIAL JOINTS, PAVEMENT MARKINGS, ETC.
- WHERE APPLICABLE, UTILITY SERVICE PROVIDER TO USE SITE HOST APPROVED ROE (RIGHT OF ENTRY) AGREEMENT. SITE HOST PROGRAM MANAGER WILL PROVIDE TEMPLATE WHEN NECESSARY.
  - SAW CUT THE PAVEMENT TO NEAT, STRAIGHT LINES TO THE FULL DEPTH OF THE PAVEMENT. PAVEMENT REMOVAL SHALL EXTEND A MINIMUM OF TWELVE INCHES (12") BEYOND THE EDGES OF THE REMOVAL AREA. ANY OTHER PAVEMENT AREAS DAMAGED DURING REMOVAL SHALL ALSO BE REPAIRED OR REPLACED AS NECESSARY
  - REMOVE THE PAVEMENT WITHOUT DAMAGING THE PAVEMENT THAT IS TO REMAIN IN-PLACE.
  - IF BASE REPLACEMENT IS REQUIRED, COMPACT THE IN-SITU SOILS TO NINETY-FIVE PERCENT (95%) ASTM D698 AND PLUS OR MINUS TWO PERCENT (2%) OF OPTIMUM MOISTURE CONTENT. REMOVE AND REPLACE ANY UNSUITABLE IN-SITU SOILS.
  - PLACE AND COMPACT BASE MATERIAL TO NINETY-FIVE PERCENT (95%) OF ASTM D698.
  - APPLY PRIME COAT TO AGGREGATE BASE IN COMPLIANCE WITH THE DOT SPECS. PRIME COAT SHALL NOT BE APPLIED MORE THAN TWENTY-FOUR (24) HOURS BEFORE ASPHALT PAVEMENT IS PLACED. APPLICATION RATE TO BE PER THE DOT SPEC.
  - CLEAN AND APPLY TACK COAT TO THE ENDS OF CURBS, EDGES OF CONCRETE SURFACES, EDGES OF MANHOLES AND INLETS AND EDGES OF SAW CUT PAVEMENT THAT WILL REMAIN IN-PLACE.
  - PLACE AND COMPACT HOT-MIX ASPHALT. HOT-MIX ASPHALT THICKNESS SHALL BE THE GREATER OF THE IN-PLACE ASPHALT OR THREE AND ONE-HALF INCHES (3.5"). ASPHALT MIX DESIGN SHALL BE BY THE CONTRACTOR.
  - PLANT MIXED ASPHALT BASE/BINDER COURSE: PROVIDE ONE COURSE LAID TO A MINIMUM COMPACTED THICKNESS OF TWO INCHES (2").
  - PLANT MIXED ASPHALT SURFACE COURSE: PROVIDE ONE COURSE LAID TO A MINIMUM COMPACTED THICKNESS OF ONE AND ONE-HALF INCHES (1-1/2").
  - FOR SMALLER JOBS, IT MAY NOT BE FEASIBLE TO INSTALL BINDER AND SURFACE COURSES, IN WHICH CASE SURFACE COURSE, PLACED AND COMPACTED IN TWO LIFTS, WILL BE ACCEPTED.
  - IF PLACING HOT MIX ASPHALT WITH A SHOVEL, BEGIN PLACING HMA AGAINST THE EDGES OF THE PATCH AND WORKING INWARD. HMA SHOULD NOT BE PLACED IN THE CENTER OF THE PATCH AND RAKED TOWARDS THE EDGES.
  - THE FIRST PASS OF THE ROLLER OR COMPACTION EQUIPMENT SHOULD BE ALONG THE EDGES OF THE PATCH TO PROPERLY FORM THE JOINT. THE ROLLER WHEEL OR COMPACTION EQUIPMENT SHOULD OVERHANG THE EXISTING PAVEMENT ONTO THE PATCH BY SIX INCHES (6"). AFTER THE PERIMETER OF THE PATCH HAS BEEN COMPACTED BEGIN TO WORK TOWARDS THE CENTER OF THE PATCH WITH SUCCESSIVE PASSES OFFSET BY SIX INCHES (6").
  - THE CONTRACTOR SHALL UTILIZE THE APPROPRIATE HEAVY COMPACTION EQUIPMENT TO ACHIEVE THE REQUIRED COMPACTION OF THE ASPHALT.
  - SEAL THE AREA AROUND THE EDGES WITH AN ELASTOMERIC LIQUID ASPHALT SEALER TO PROTECT AGAINST WATER INFILTRATION, INCLUDING ANY INADVERTENT OVERCURTS DURING THE SAW CUTTING PROCEDURE.

**PROJECT LEGEND:**  
(SCALE VARIES PER SHEET)

DETAIL NO.	SHEET NO.
	BREAK LINE
	PROPERTY LINE
	EXISTING CURB AND GUTTER
	EXISTING CURB
	EXISTING PARKING STRIPE
	EXISTING CONCRETE PAD
	EXISTING TREE
	EXISTING SHRUB
	EXISTING FIRE HYDRANT
	EXISTING CURB INLET
	EXISTING INLET
	EXISTING CATCH BASIN
	EXISTING MANHOLE
	EXISTING POWER POLE
	EXISTING LIGHT POLE
	EXISTING SIGN
	EXISTING ELECTRICAL ROOM
	PROPOSED ELECTRICAL CONDUIT
	PROPOSED ELECTRICAL JUNCTION BOX
	PROPOSED COMMUNICATIONS CONDUIT
	PROPOSED COMMUNICATIONS JUNCTION BOX
	PROPOSED CURB AND GUTTER
	PROPOSED CURB
	PROPOSED PARKING STRIPE
	PROPOSED CONCRETE PAD
	PROPOSED CONCRETE WHEEL STOP
	PROPOSED TREE PROTECTION
	PROPOSED VOLTA CHARGING STATION
	EVCS FOUNDATION W/ 4" PIPE BOLLARDS
	PCS FOUNDATION
	PCS FOUNDATION W/ 4" BOLLARDS
	REMOTE HOLSTER RAISED FOUNDATION WITH 6" CURB
	REMOTE HOLSTER FLUSH FOUNDATION
	PROPOSED SIGN POST
	PROPOSED SIGN POST W/ BOLLARD
	PROPOSED POST INSTALLED SIGN POST
	PROPOSED POST INSTALLED SIGN POST W/ BOLLARD
	PROPOSED 4" ISOLATED PIPE BOLLARD

NOTE: THE ORIGINAL SIZE OF THIS PLAN IS 24" X 36". SCALE RATIO IS NOT VALID FOR REDUCED OR ENLARGED SHEET SIZES

**VOLTA**

155 DE HARO STREET  
SAN FRANCISCO, CA 94103

**Kimley»Horn**

1 N LEXINGTON AVE, SUITE 505  
WHITE PLAINS, NY 10601  
Main: 914.368.9200 | www.kimley-horn.com  
© 2021 Kimley-Horn and Associates, Inc.

REV	DATE	DESCRIPTION	BY
1	03/03/2021	CD90s	TAS
2	05/05/2021	CD100s	TAS
3	07/21/2021	CD100s	TAS

ISSUE DATE  
**05/05/2021**

ISSUED FOR  
**PERMIT**

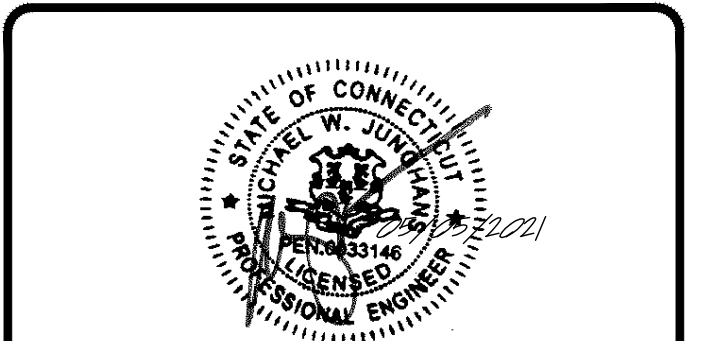

IT IS A VIOLATION OF LAW FOR ANY PERSON, UNLESS THEY ARE ACTING UNDER THE DIRECTION OF A LICENSED PROFESSIONAL ENGINEER, TO ALTER THIS DOCUMENT.

**STOP & SHOP #2604  
TORRINGTON**  
931 TORRINGTON STREET  
TORRINGTON, CT 06790

SHEET TITLE  
**GENERAL NOTES**

SHEET NUMBER  
**C0-01**

# Volta Gen4 L2 Station

Volta provides turn-key Electric Vehicle (EV) charging services for premium retail and entertainment destinations. We install and maintain the charging amenity at no cost to site partners as well as EV drivers, driving increased property value and attracting more customers who stay longer.

### VOLTA STATION BENEFITS

- Installation, equipment and maintenance is paid by Volta
- Charges all electric vehicles
- Free electricity supported through third party content on displays
- Volta stations are occupied 80% of the retail day
- Volta has provided 88M free sponsored electric miles, delivered 25 gigawatt hours and eliminated over 39M pounds of CO2 emissions

### CHARGING UNIT INFORMATION (Single Charging Units)

- Size: H 85.0" x W 36.5" x D 15.5"
- Display Size: H 48" x W 27"
- Power Type: 208/240VAC, 48A, 10kW max; UL 2202
- Plug: SAE J1772 compliant connector

### POWER REQUIREMENTS

- Charging unit: 60A/2P, 208/240 breaker
- Display/connectivity: 20A/1P, 120V breaker

### INSTALLATION REQUIREMENTS

- Wire Diameter: #6 AWG minimum. Larger for longer conduit runs
- Conduit Diameter: 1.5" minimum per station. Larger conduit required for runs over 250'



55" Media Display

Charges up to 30miles per hour

Universal J1772 connections

Cable Management

Fully Networked



## VOLTA

155 DE HARO STREET  
SAN FRANCISCO, CA 94103

## Kimley»Horn

1 N LEXINGTON AVE, SUITE 505  
WHITE PLAINS, NY 10601  
Main: 914.368.9200 | www.kimley-horn.com  
© 2021 Kimley-Horn and Associates, Inc.

REV	DATE	DESCRIPTION	BY
1	03/03/2021	CD90s	TAS
2	05/05/2021	CD100s	TAS
3	07/21/2021	CD100s	TAS

ISSUE DATE

**05/05/2021**

ISSUED FOR

**PERMIT**

**FOR  
INFORMATIONAL  
PURPOSES ONLY**

IT IS A VIOLATION OF LAW FOR ANY PERSON, UNLESS THEY ARE ACTING UNDER THE DIRECTION OF A LICENSED PROFESSIONAL ENGINEER, TO ALTER THIS DOCUMENT.

**STOP & SHOP #2604  
TORRINGTON**

**931 TORRINGTON STREET  
TORRINGTON, CT 06790**

SHEET TITLE

**VOLTA STATION  
OVERVIEW**

SHEET NUMBER

**C0-02**

volta

Proprietary & Confidential - Do Not Distribute

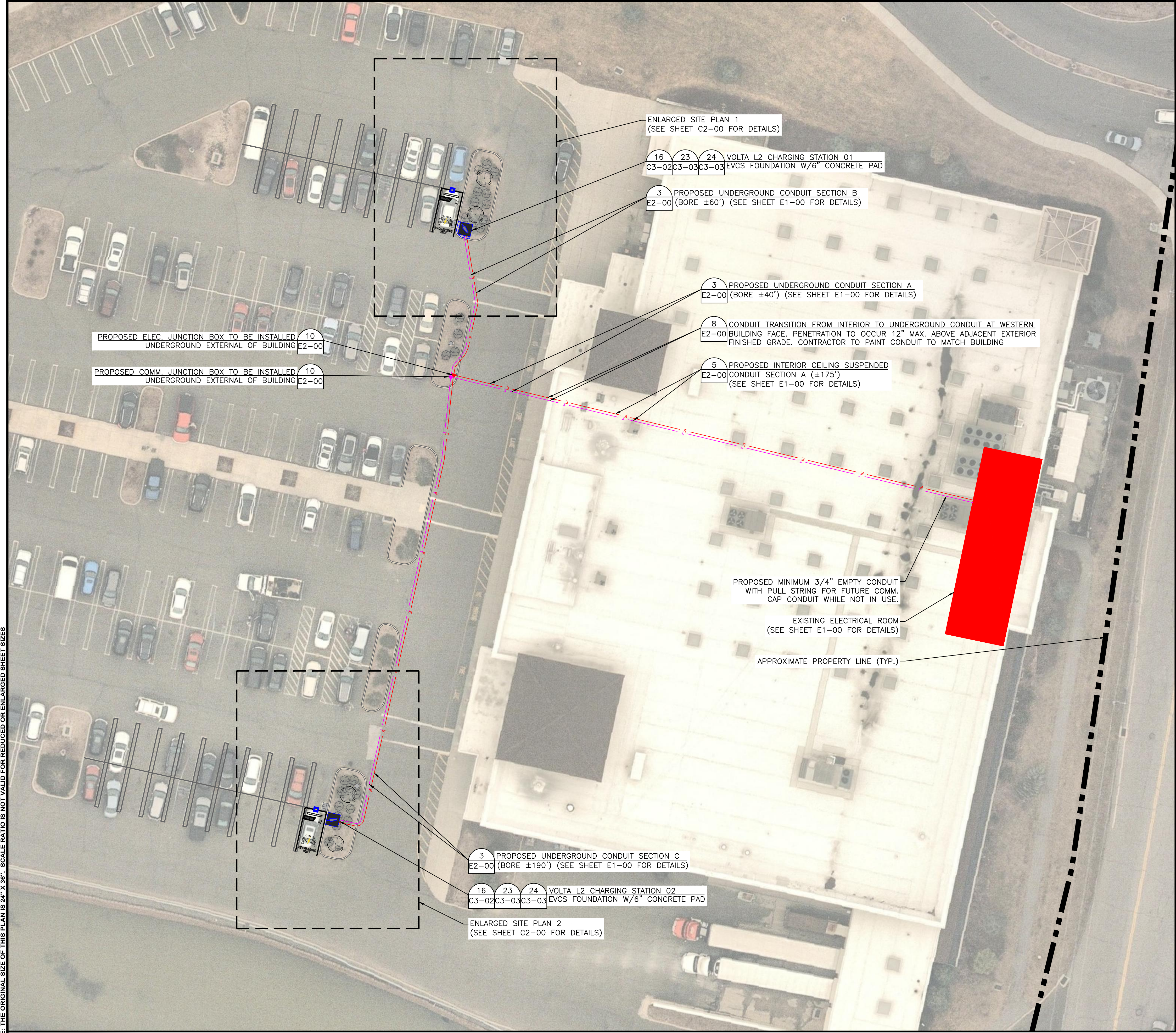

NOTE: THE ORIGINAL SIZE OF THIS PLAN IS 24" X 36". SCALE RATIO IS NOT VALID FOR REDUCED OR ENLARGED SHEET SIZES

**OVERALL SITE PLAN**

**DISCLAIMER**

THESE DRAWINGS WERE PRODUCED WITHOUT THE BENEFIT OF A CURRENT LAND SURVEY. ALL PROPERTY LINES, EASEMENTS, SETBACKS, EXISTING INFRASTRUCTURE AND TITLE DOCUMENTS SHALL BE VERIFIED PRIOR TO START OF CONSTRUCTION. KIMLEY-HORN AND VOLTA DO NOT GUARANTEE THE ACCURACY OF SAID PROPERTY LINES, EASEMENTS, SETBACKS, EXISTING INFRASTRUCTURE AND TITLE DOCUMENTS.

CONTRACTOR IS RESPONSIBLE FOR VERIFYING ALL FIELD CONDITIONS AND IS TO ALERT THE ENGINEER AND VOLTA OF ANY DISCREPANCIES PRIOR TO STARTING CONSTRUCTION. CONTRACTOR TO COORDINATE WITH VOLTA PM FOR ALL FINAL PLACEMENTS OF INFRASTRUCTURE.

**CONSTRUCTION NOTES:**

- CONTRACTOR RESPONSIBILITIES CONSISTS OF, BUT NOT LIMITED TO, CHARGING STATION MOUNTING, FOUNDATION CONSTRUCTION, CONDUIT INSTALLATION, AND WIRING.
- CONTRACTOR TO PAINT PROPOSED EV PARKING SPACES PER JURISDICTIONAL REQUIREMENTS.
- CONTRACTOR TO INSTALL TREE PROTECTION FENCING PRIOR TO ANY CONSTRUCTION ACTIVITY. SEE SHEET C3-00 FOR DETAILS.
- EXACT STATION PLACEMENT AND ROTATION ANGLE MAY VARY SLIGHTLY UPON INSTALLATION DEPENDING ON SITE CONDITIONS.
- CONTRACTOR TO FIELD VERIFY ALL STALL DIMENSIONS AND ALL EQUIPMENT LOCATIONS TO ENSURE SUFFICIENT SPACE IS AVAILABLE.
- CONTRACTOR SHALL TAKE NECESSARY PRECAUTIONS WHEN DRILLING INTO EXISTING CIP SLAB AND CIP DROP PANELS TO AVOID DAMAGE TO ANY REINFORCING AND EXISTING STRUCTURAL COMPONENTS.
- USE APPROVED ASTM METHOD (X-RAY, PACOMETER, GPR, ETC.) TO LOCATE MILD STEEL AND PRE-STRESSING TENDONS PRIOR TO DRILLING. DO NOT CUT OR DRILL THROUGH ANY EXISTING REINFORCING. ADJUST LOCATION AS NECESSARY TO AVOID EXISTING REINFORCING. ENSURE 1" GAP MIN. BETWEEN REBAR AND ANCHORAGE.
- VOLTA WILL MAKE EVERY EFFORT TO FOLLOW, WITH THEIR PROPOSED CONDUIT, AN EXISTING CONDUIT ROUTE FROM ELECTRICAL ROOM TO PROPOSED STATION PLACEMENTS. WHEN AN EXISTING ROUTE IS NOT AVAILABLE, VOLTA WILL MAKE EVERY EFFORT TO CONCEAL/HIDE, PAINT AND MINIMIZE VISUAL IMPACT OF CONDUITS ANYWHERE THEY MAY BE VISIBLE TO THE PUBLIC.
- CONTRACTOR IS RESPONSIBLE TO LOCATE ALL VERTICAL AND HORIZONTAL UTILITIES PRIOR TO DIRECTIONAL BORING. ANY ALTERATIONS TO THE PROPOSED CONDUIT ROUTE ARE TO BE COORDINATED WITH THE PROFESSIONAL ENGINEER(S) PRIOR TO CONSTRUCTION.
- ANY ITEMS TO REMAIN THAT ARE DAMAGED BY THE CONTRACTOR SHALL BE REPLACED TO THE EXISTING CONDITION OR BETTER AT THE CONTRACTOR'S EXPENSE.
- CONTRACTOR TO LOCATE JUNCTION BOX OR APPROVED ALTERNATIVE FOR SITE SPECIFIC RUN LENGTHS AND BENDS.

**PARKING NOTE:**

- FOR THE PURPOSE OF THIS PLAN IT IS ASSUMED THERE IS ADEQUATE PARKING IN EXISTING CONDITIONS TO CONVERT 2 PARKING SPACES TO 2 EV PARKING SPACES.

**REFERENCE NOTE:**

- SEE PROJECT LEGEND ON SHEET C0-01 FOR SYMBOLS AND LINE TYPE DESCRIPTIONS.

**IMAGE REFERENCE:**

AERIAL IMAGE(S) PROVIDED BY NEARMAP IMAGERY ©2021 Nearmap, HERE

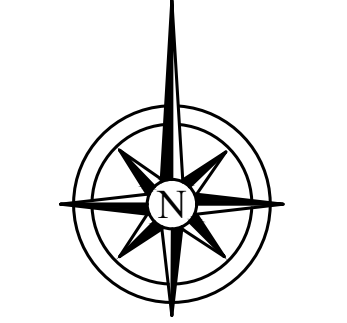

GRAPHIC SCALE IN FEET  
0 10 20 40

**VOLTA**

155 DE HARO STREET  
SAN FRANCISCO, CA 94103

**Kimley»Horn**

1 N LEXINGTON AVE, SUITE 505  
WHITE PLAINS, NY 10601  
Main: 914.368.9200 | www.kimley-horn.com  
© 2021 Kimley-Horn and Associates, Inc.

REV	DATE	DESCRIPTION	BY
1	03/03/2021	CD90s	TAS
2	05/05/2021	CD100s	TAS
3	07/21/2021	CD100s	TAS

ISSUE DATE  
**05/05/2021**

ISSUED FOR  
**PERMIT**

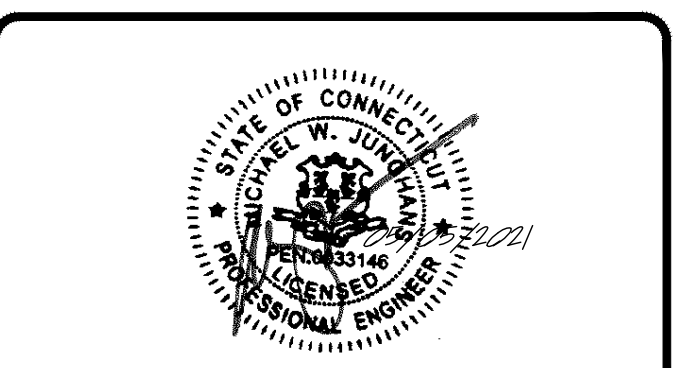

IT IS A VIOLATION OF LAW FOR ANY PERSON, UNLESS THEY ARE ACTING UNDER THE DIRECTION OF A LICENSED PROFESSIONAL ENGINEER, TO ALTER THIS DOCUMENT.

**STOP & SHOP #2604  
TORRINGTON**

931 TORRINGTON STREET  
TORRINGTON, CT 06790

SHEET TITLE  
**OVERALL SITE  
PLAN**

SHEET NUMBER  
**C1-00**



NOTE: THE ORIGINAL SIZE OF THIS PLAN IS 24" X 36". SCALE RATIO IS NOT VALID FOR REDUCED OR ENLARGED SHEET SIZES

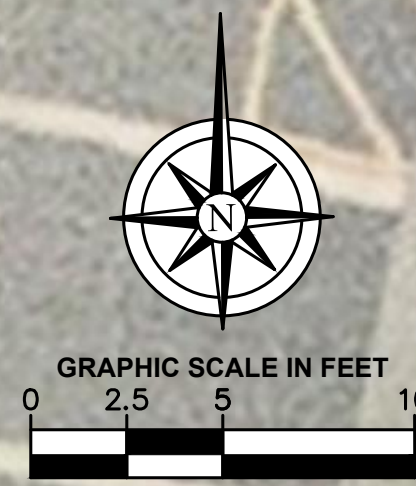

1

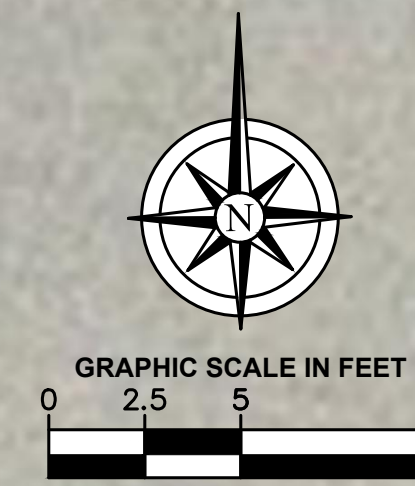
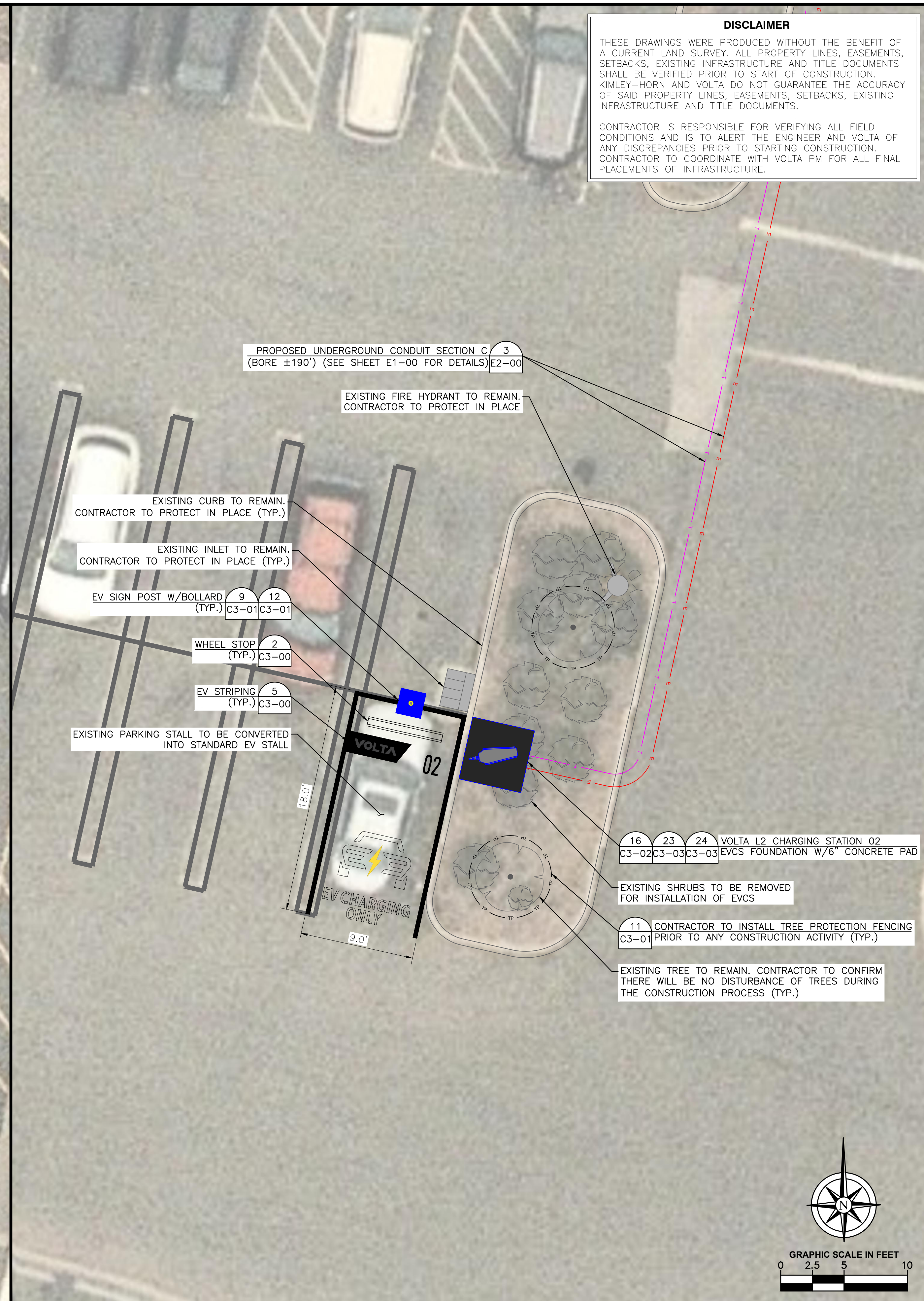

2

**DISCLAIMER**  
 THESE DRAWINGS WERE PRODUCED WITHOUT THE BENEFIT OF A CURRENT LAND SURVEY. ALL PROPERTY LINES, EASEMENTS, SETBACKS, EXISTING INFRASTRUCTURE AND TITLE DOCUMENTS SHALL BE VERIFIED PRIOR TO START OF CONSTRUCTION. KIMLEY-HORN AND VOLTA DO NOT GUARANTEE THE ACCURACY OF SAID PROPERTY LINES, EASEMENTS, SETBACKS, EXISTING INFRASTRUCTURE AND TITLE DOCUMENTS.  
 CONTRACTOR IS RESPONSIBLE FOR VERIFYING ALL FIELD CONDITIONS AND IS TO ALERT THE ENGINEER AND VOLTA OF ANY DISCREPANCIES PRIOR TO STARTING CONSTRUCTION. CONTRACTOR TO COORDINATE WITH VOLTA PM FOR ALL FINAL PLACEMENTS OF INFRASTRUCTURE.

**VOLTA**  
 155 DE HARO STREET  
 SAN FRANCISCO, CA 94103

**Kimley»Horn**  
 1 N LEXINGTON AVE, SUITE 505  
 WHITE PLAINS, NY 10601  
 Main: 914.368.9200 | www.kimley-horn.com  
 © 2021 Kimley-Horn and Associates, Inc.

REV	DATE	DESCRIPTION	BY
1	03/03/2021	CD90s	TAS
2	05/05/2021	CD100s	TAS
3	07/21/2021	CD100s	TAS

ISSUE DATE  
**05/05/2021**

ISSUED FOR  
**PERMIT**

IT IS A VIOLATION OF LAW FOR ANY PERSON, UNLESS THEY ARE ACTING UNDER THE DIRECTION OF A LICENSED PROFESSIONAL ENGINEER, TO ALTER THIS DOCUMENT.

**STOP & SHOP #2604 TORRINGTON**  
 931 TORRINGTON STREET  
 TORRINGTON, CT 06790

SHEET TITLE  
**ENLARGED SITE PLAN**

SHEET NUMBER  
**C2-00**

- UNLESS NOTED OTHERWISE, THE FOLLOWING NOTES RELATING TO THE "SITE DETAILS" SHEETS SHALL GOVERN.
- COMPRESSIVE STRENGTH OF CONCRETE FOUNDATION SHALL BE A MINIMUM OF 4,500 PSI AT 28 DAYS WITH MAXIMUM W/C RATIO OF 0.45 AND AIR-CONTENT OF 5% +/- 1.5%.
- MINIMUM YIELD STRENGTH OF REINFORCEMENT TO BE 60,000 PSI (ASTM-A615).
- REFERENCE CIVIL AND ELEC DRAWING FOR EQUIPMENT LAYOUT, LOCATION OF CONDUIT, ETC.
- FINAL ANCHOR BOLT AND POLE DESIGN INCLUDING SIZE AND CONFIGURATION ARE BY MFR.
- BEFORE STARTING ANY WORK, THE CONTRACTOR SHALL VERIFY ALL DIMENSIONS ON THE SITE AND REPORT ANY DISCREPANCIES IMMEDIATELY TO THE ENGINEER.
- NO GEOTECHNICAL ENGINEERING REPORT WAS PROVIDED BY THE OWNER. FOUNDATION DESIGN IS BASED ON A MINIMUM OF 1,500 PSF NET ALLOWABLE BEARING PRESSURE ON UNDISTURBED NATURAL SOIL OR COMPACTED FILL UNLESS OTHERWISE NOTED, UNLESS OTHERWISE DIRECTED BY THE OWNER. ALL FOUNDATION WORK RELATED TO INSTALLATION OF REBAR SHALL BE INSPECTED BY OTHERS.
- KIMLEY-HORN AND ASSOCIATES, INC. IS NOT RESPONSIBLE FOR THE DESIGN OF THE EQUIPMENT OR ANCHORAGE TO THE FOUNDATION. MANUFACTURER SHALL SUBMIT LOADS TO ENGINEER FOR RECORD KEEPING PURPOSES ONLY.
- DESIGN IS BASED ON THE SPECIFIC EQUIPMENT SHOWN IN THESE DRAWINGS AND ILLUSTRATED ON THE VOLTA CUT SHEETS.
- ALL MATERIALS SHALL BE IN ACCORDANCE WITH THE LOCAL DEPARTMENT OF TRANSPORTATION SPECIFICATIONS.
- ALL FOUNDATIONS ARE TO INCLUDE COMPACTED SUBGRADE AND MINIMUM 6" COMPACTED STONE BASE UNLESS OTHERWISE SPECIFIED.
- BUILDING CODE: IBC 2018
  - DESIGN LOADS
  - DEAD LOAD: SELF WEIGHT
  - LIVE LOAD: BOLLARDS ARE NOT DESIGNED FOR FULL 6 KIP IMPACT LOAD UNLESS OTHERWISE NOTED "VEHICULAR RATED"
  - WIND LOAD: ASCE 7-10
    - OCCUPANCY CATEGORY = II
    - WIND SPEED = 170 MPH
    - EXPOSURE = B

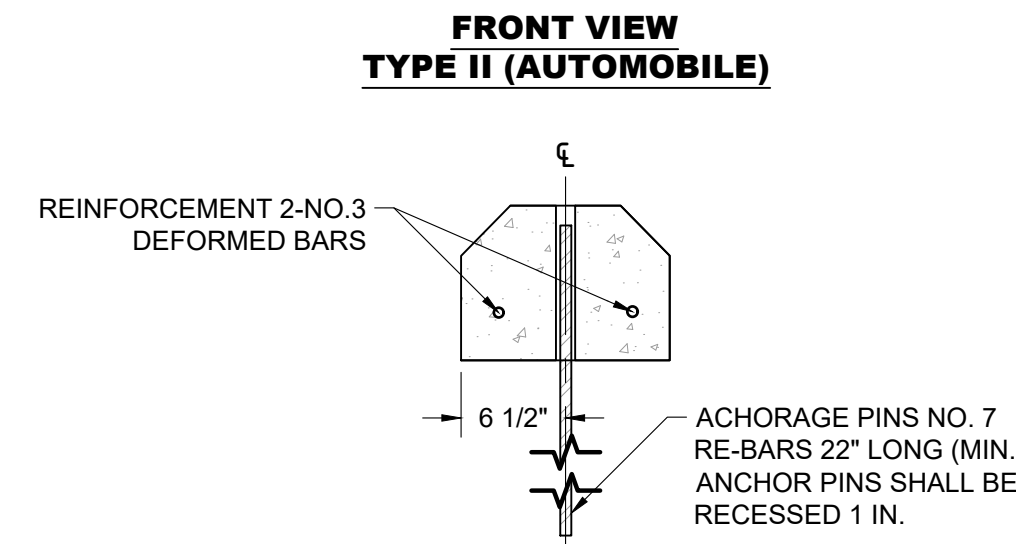
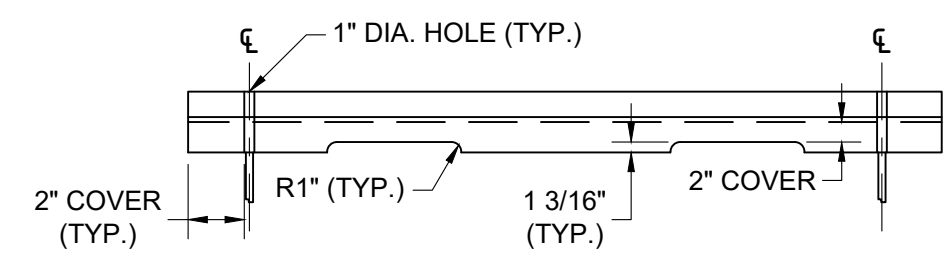

- NOTES:
- PRECAST CONCRETE WHEEL STOPS SHALL BE LOCATED AS SHOWN ON THE PLANS. THEN SECURED IN PLACE WITH TWO (2) NO. 7 REINFORCEMENT BARS PER WHEEL STOP.
  - COST OF THE REINFORCEMENT BARS WILL BE INCIDENTAL TO THE CONTRACT UNIT PRICE BID PER EACH FOR THE WHEEL STOPS.
  - WHEEL STOPS TO BE PAINTED WHITE IN ACCORDANCE WITH STRIPING GUIDELINES.

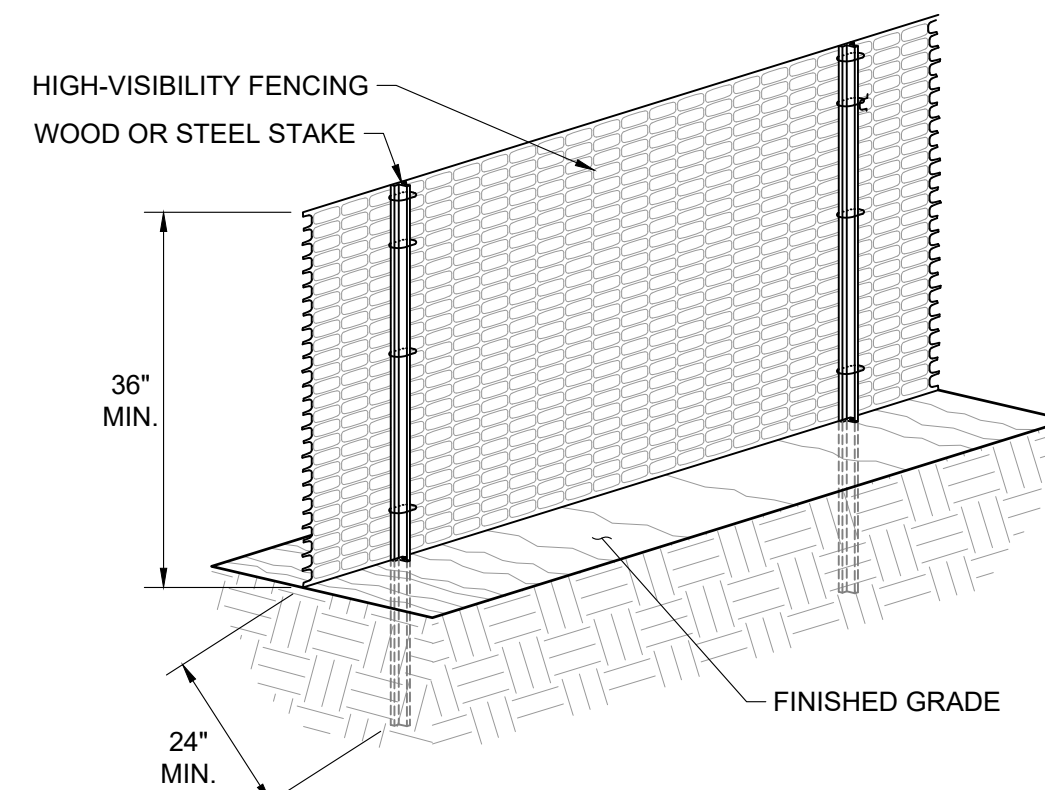
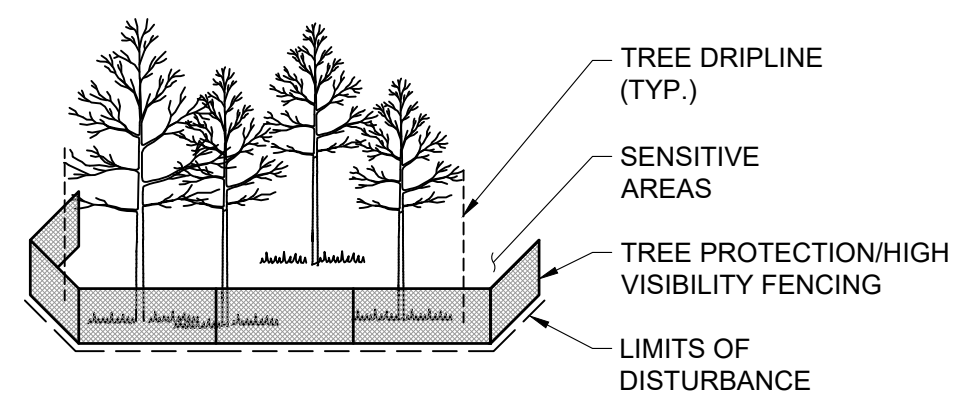

NOTE: FURNISH AND INSTALL TEMPORARY HIGH-VISIBILITY FENCING AT CONSTRUCTION LIMITS PRIOR TO ANY LAND DISTURBANCE.

- NOTES:
- REMOTE CHARGING PEDESTAL TO BE PROVIDED BY VOLTA.
  - CHARGING CABLE TO BE ROUTED FROM EV KIOSK TO HOLSTER THROUGH UNDERGROUND CONDUITS AS SHOWN BELOW.
  - AT CONTRACTOR'S OPTION A 24\"/>

VOLTAGE DROP TABLE							
START POINT	END POINT	AMPERAGE (A)	VOLTAGE	DISTANCE (FT)	CONDUCTOR (AWG)	CONDUCTOR RESISTANCE	V.D. %
EV#	REMOTE PEDESTAL	40	208	5	6	0.51	0.20
EV#	REMOTE PEDESTAL	40	208	20	6	0.51	0.82
EV#	REMOTE PEDESTAL	40	208	35	6	0.51	1.43
EV#	REMOTE PEDESTAL	40	208	50	6	0.51	2.04

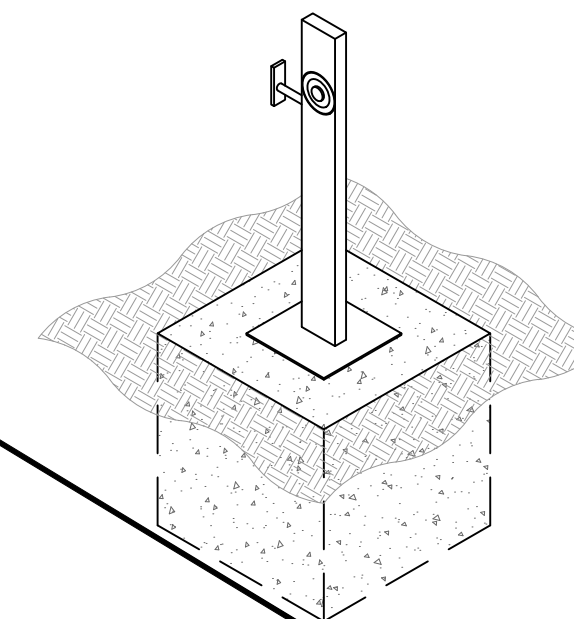
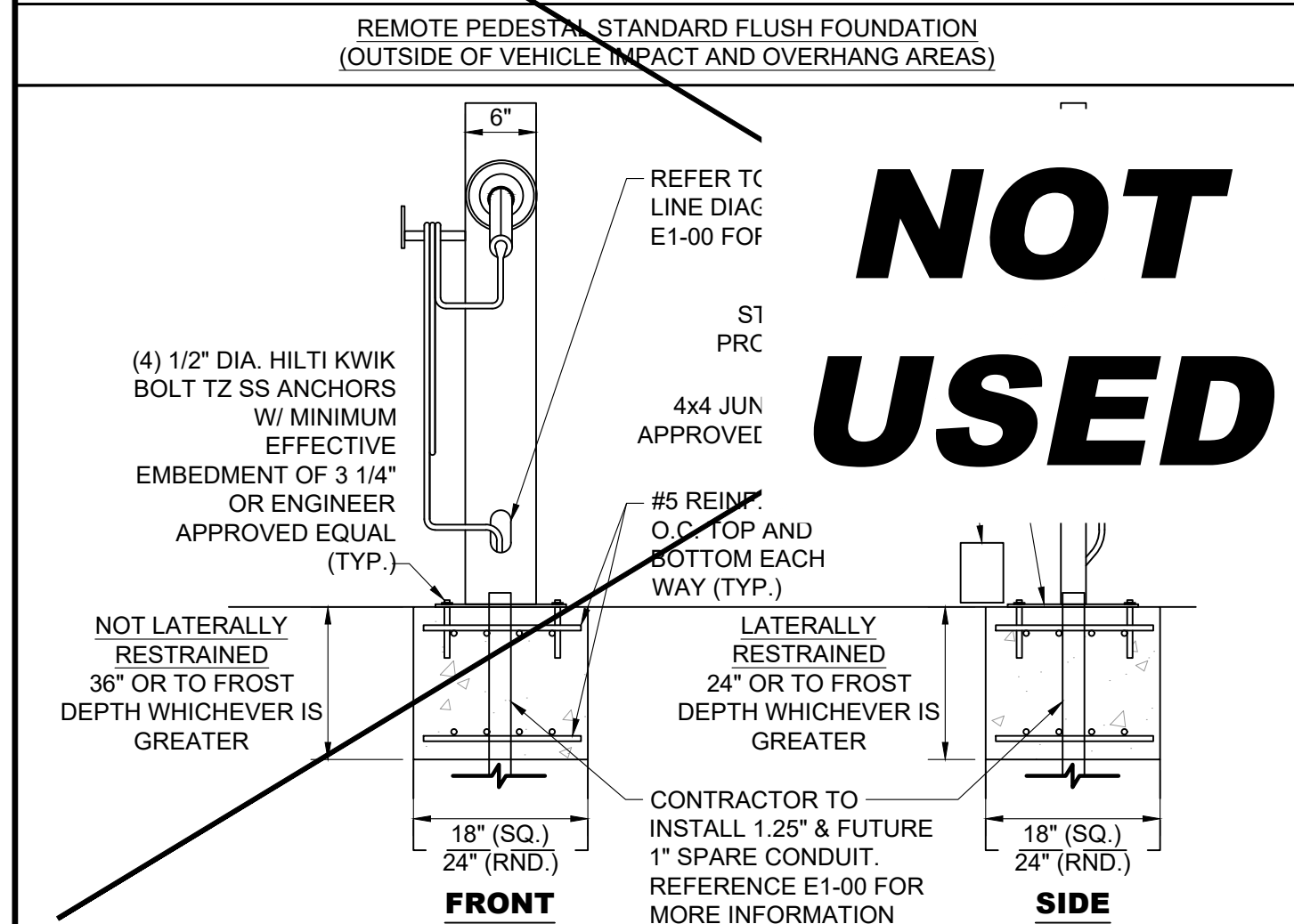

**GENERAL NOTES** SCALE N.T.S. 1

**CONCRETE WHEEL STOP** SCALE N.T.S. 2

**TREE PROTECTION** SCALE N.T.S. 3

**FLUSH REMOTE PEDESTAL FOUNDATION** SCALE N.T.S. 4

**VOLTA**  
155 DE HARO STREET  
SAN FRANCISCO, CA 94103

**Kimley Horn**  
1 N LEXINGTON AVE, SUITE 505  
WHITE PLAINS, NY 10601  
Main: 914.368.9200 | www.kimley-horn.com  
© 2021 Kimley-Horn and Associates, Inc.

REV	DATE	DESCRIPTION	BY
1	03/03/2021	CD90s	TAS
2	05/05/2021	CD100s	TAS
3	07/21/2021	CD100s	TAS

ISSUE DATE  
**05/05/2021**

ISSUED FOR  
**PERMIT**

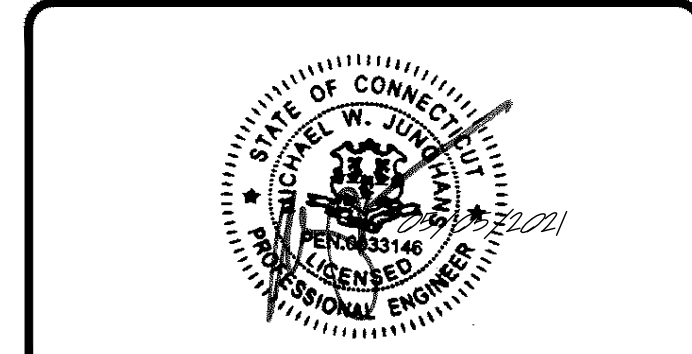

IT IS A VIOLATION OF LAW FOR ANY PERSON, UNLESS THEY ARE ACTING UNDER THE DIRECTION OF A LICENSED PROFESSIONAL ENGINEER, TO ALTER THIS DOCUMENT.

**STOP & SHOP #2604 TORRINGTON**  
931 TORRINGTON STREET  
TORRINGTON, CT 06790

SHEET TITLE  
**SITE DETAILS**

SHEET NUMBER  
**C3-00**

**FOR REFERENCE ONLY, DESIGNED AND PROVIDED BY OTHERS**

Volta Charging  
**STRIPING GUIDELINES**

**PRODUCTS**  
Cement Background: Benjamin Moore Floor & Patio Battleship Blue N122-2X 512x30.0 811x0.0 610x30.0  
Asphalt Background: Latex-tie 4.75 Gal. Ultra Shield Driveway Filler Sealer  
Traffic Paint: Sherwin Williams TM2153 LF Yellow TTP-1952D, TM2152 White TTP-1952D

**SURFACE PREP**  
Backgrounds are to only be painted for marquee locations or any location where the existing space has conflicting designations or is poor shape. For all other instances please proceed to branded striping.

**CEMENT BACKGROUND:**  
For cement backgrounds please use battleship blue. All backgrounds must run edge-to-edge across the entire parking space.

**ASPHALT BACKGROUND:**  
Asphalt should be resealed with sealcoat. All backgrounds must run edge-to-edge across the entire parking space.

**BRANDED STRIPING**

**VOLTA LOGO:**  
Should match the overall background color of the parking stall (unless you are omitting the container shape according to other specs, if so paint it white).

**LINES & STENCILS:**  
Use traffic grade yellow for the lightning bolt stencil. Use traffic grade white for all other lines and stencils.

- SHAPE (WHITE)** Place flush with the top left corner.
- VOLTA LOGO** Center within the shape.
- NUMBERS (WHITE)** The right number lines up flush right to the "G" in "CHARGING" and flush top with the Volta logo. There should be 3 inches in-between the left and right numbers. If stall is less than 8 feet, align numbers with the middle of the "G" (See page 2).
- LETTERS** Place centered, 4 inches from the bottom of the stall.
- CAR** Place centered 14 inches from the top of the letters.

\*Mock up to scale 9'x18' stall.

1 of 3  
volta Founded in 2010. Designed in San Francisco, built to last in the USA. info@voltacharging.com

**FOR REFERENCE ONLY, DESIGNED AND PROVIDED BY OTHERS**

Volta Charging  
**STRIPING GUIDELINES**

**ABSOLUTELY DO NOT**

- Paint only a portion of the background (edge-to-edge or not at all)
- Paint the lightning bolt, any color but yellow or white
- Only put 1 number in top right corner
- Paint the Volta logo any color other than white or Battleship Blue/Sealcoat

**ACCESSORIES**

**HEEL BLOCKS** Place 8 inches above the logo, centered within the stall. Wheel should be painted white.

**ESS AISLE** Should be painted white.

No need to paint the curbs unless they meet an existing or conflicting color. If the case, paint the curb white.

**NOT USED**

\*Mock up to scale 12'x18' stall with 5' access aisle.

2 of 3  
volta Founded in 2010. Designed in San Francisco, built to last in the USA. info@voltacharging.com

**FOR REFERENCE ONLY, DESIGNED AND PROVIDED BY OTHERS**

Volta Charging  
**STRIPING GUIDELINES**

**DIAGONAL STALLS**

- SHAPE (SEE PAGE 1)** Omit in diagonal spaces.
- VOLTA LOGO (WHITE)** 6 inches from the top line at the same angle as the stall lines.
- NUMBERS (WHITE)** The right number lines up flush right to the "G" in "CHARGING" and flush top with the Volta logo at same angle as the stall lines. There should be 3 inches in-between the left and right numbers. If stall is less than 8 feet, align numbers with the middle of the "G" (See diagram)
- LETTERS** Place centered, 4 inches from the bottom of the stall according to the top line.

Place centered 14 inches from the top of the stall at the same angle as the stall lines.

**HEEL BLOCKS** Place 8 inches above the logo in the same angle as the stall lines. Wheel should be painted white.

**NOT USED**

\*Mock up to scale 6'x14' stall at 45° angle.

3 of 3  
volta Founded in 2010. Designed in San Francisco, built to last in the USA. info@voltacharging.com

**EV STRIPING GUIDELINES** SCALE N.T.S. 5

**EV STRIPING GUIDELINES** SCALE N.T.S. 6

**EV STRIPING GUIDELINES** SCALE N.T.S. 7

NOTE: THE ORIGINAL SIZE OF THIS PLAN IS 24" X 36". SCALE RATIO IS NOT VALID FOR REDUCED OR ENLARGED SHEET SIZES

NOTE: THE ORIGINAL SIZE OF THIS PLAN IS 24" X 36". SCALE RATIO IS NOT VALID FOR REDUCED OR ENLARGED SHEET SIZES

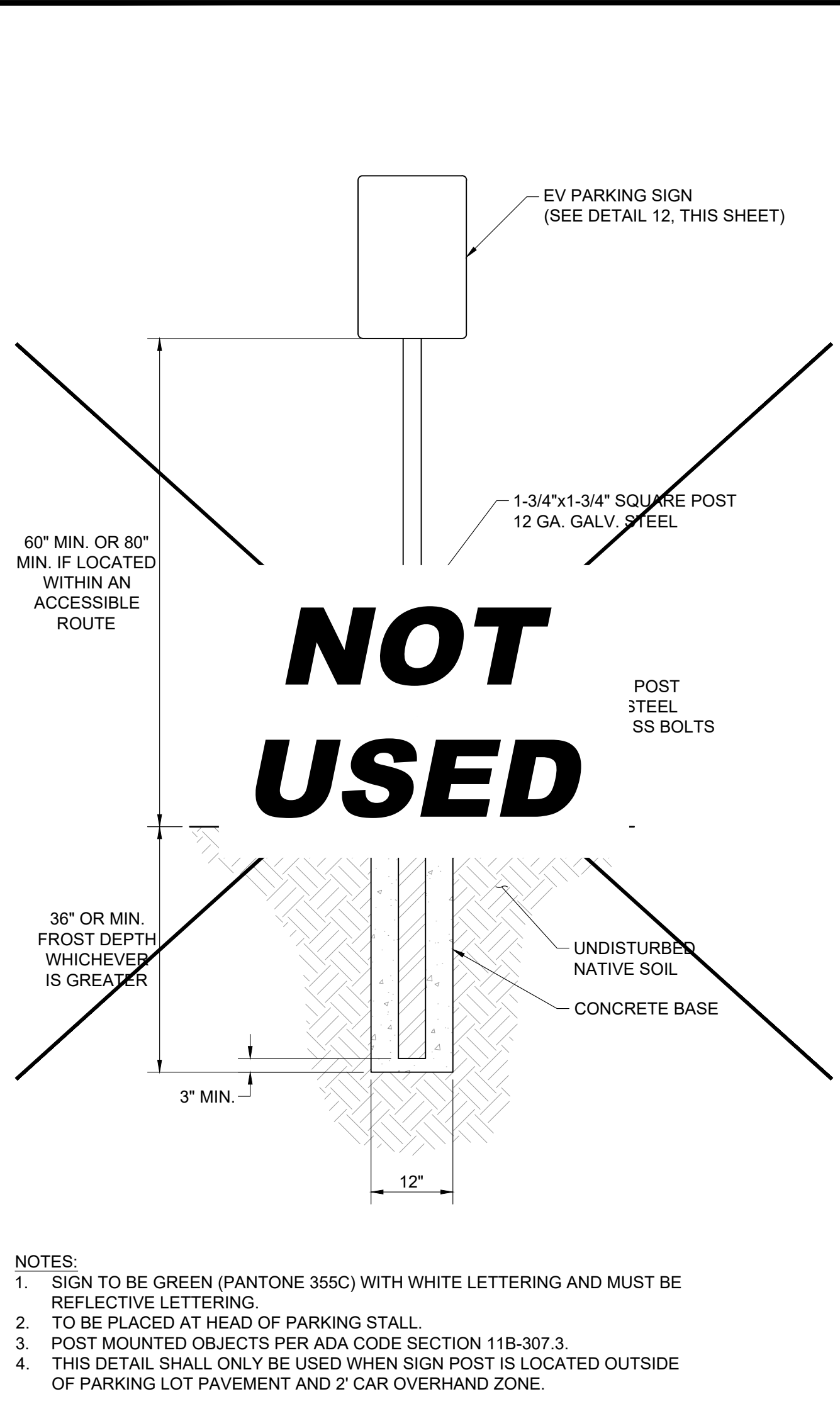

**SIGN POST** SCALE N.T.S. 8

**FOR REFERENCE ONLY, DESIGNED AND PROVIDED BY OTHERS.**

**NO TIME LIMIT SIGN**  
STADIUMS, OTHER VENUES, ECT.

**45 MIN. TIME LIMIT SIGN**  
FAST FOOD RESTAURANTS, ECT.

**1 HR. TIME LIMIT SIGN**  
DRUG STORES OR SIMILAR QUICK CONVENIENCE SITES

**2 HR. TIME LIMIT SIGN**  
GROCERY STORES, MALLS, ECT.

**3 HR. TIME LIMIT SIGN**  
MOVIE THEATERS, ENTERTAINMENT CENTERS, ECT.

**30 MIN. TIME LIMIT SIGN**  
DCFC STALLS

**SIGN INSTALLATION TYPE:**  
CONTRACTOR SHALL COORDINATE WITH VOLTA TO DETERMINE EVCS SIGN TYPE PRIOR TO INSTALLATION.

**SIGN INSTALLATION HEIGHT:**  
ALL SIGNS TO BE INSTALLED AT 60" ABOVE FINISH FLOOR. IF SIGNS ARE LOCATED WITHIN AN ACCESSIBLE ROUTE, THEY WILL BE INSTALLED AT 80" ABOVE FINISHED FLOOR. MEASUREMENTS ARE TAKEN FROM BOTTOM OF LOWEST SIGN.

**SIGN REQUIREMENTS** SCALE N.T.S. 12

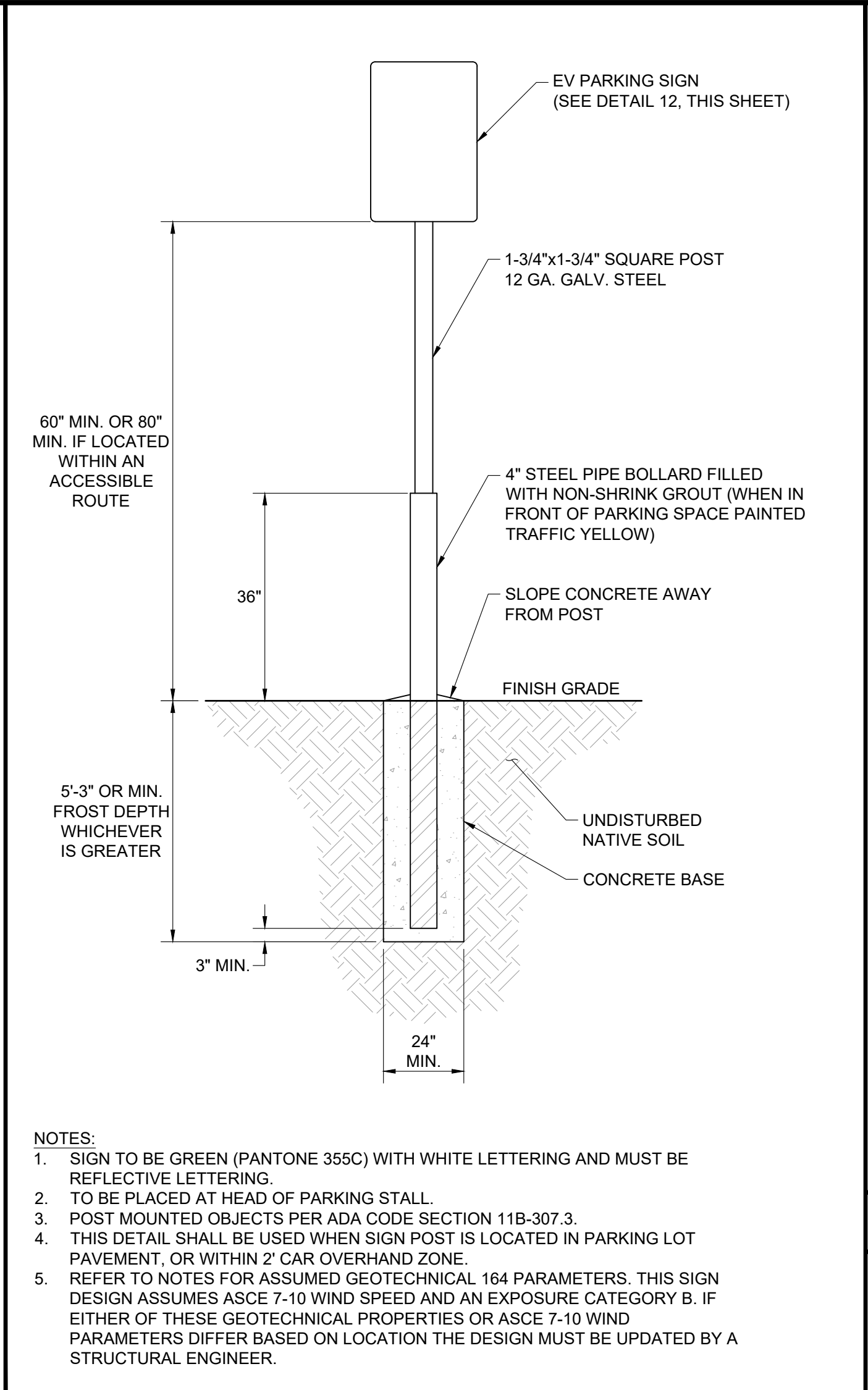

**SIGN POST W/BOLLARD** SCALE N.T.S. 9

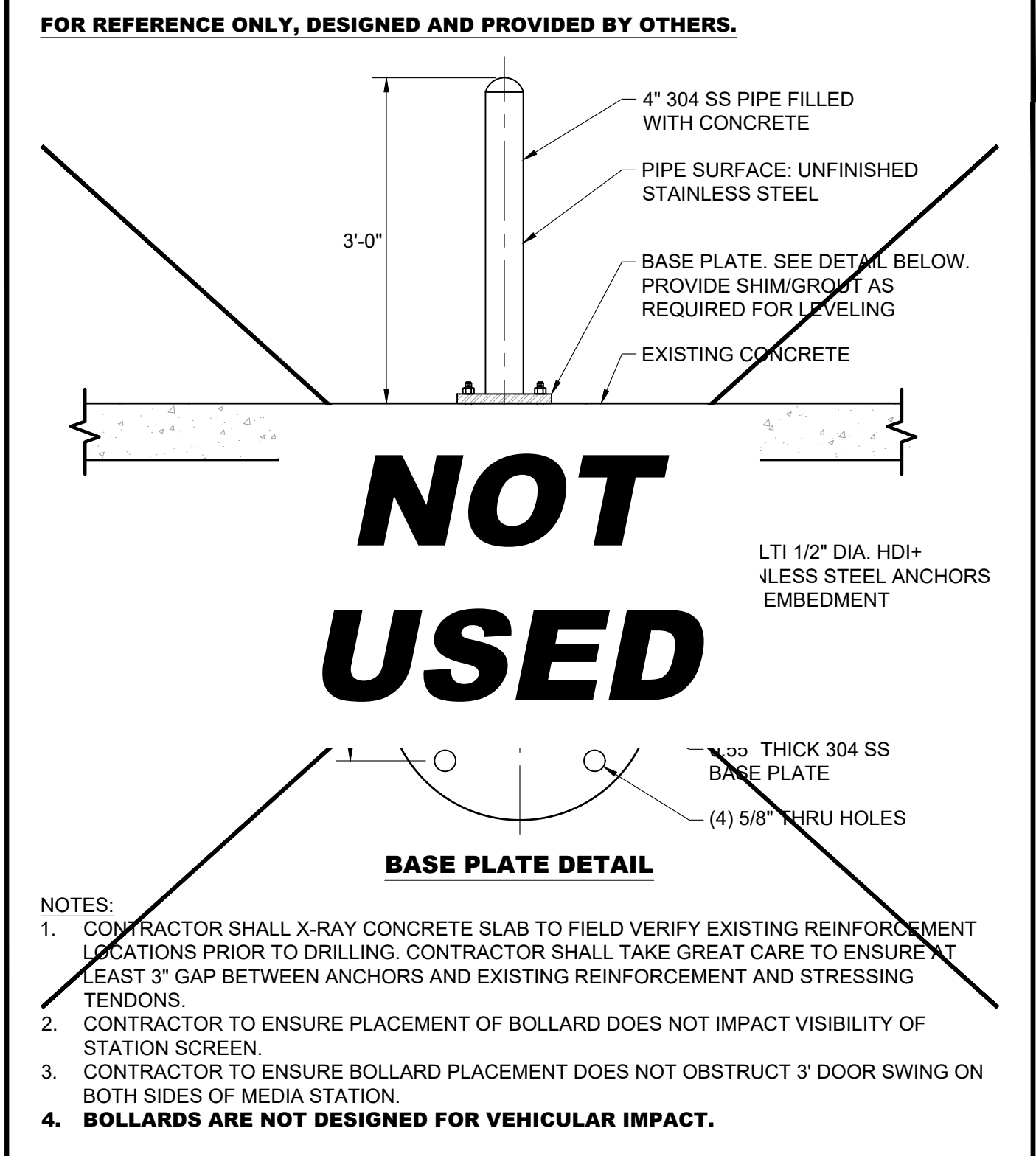

**4" DETERRENT BOL. W/ BASE PLATE** SCALE N.T.S. 13

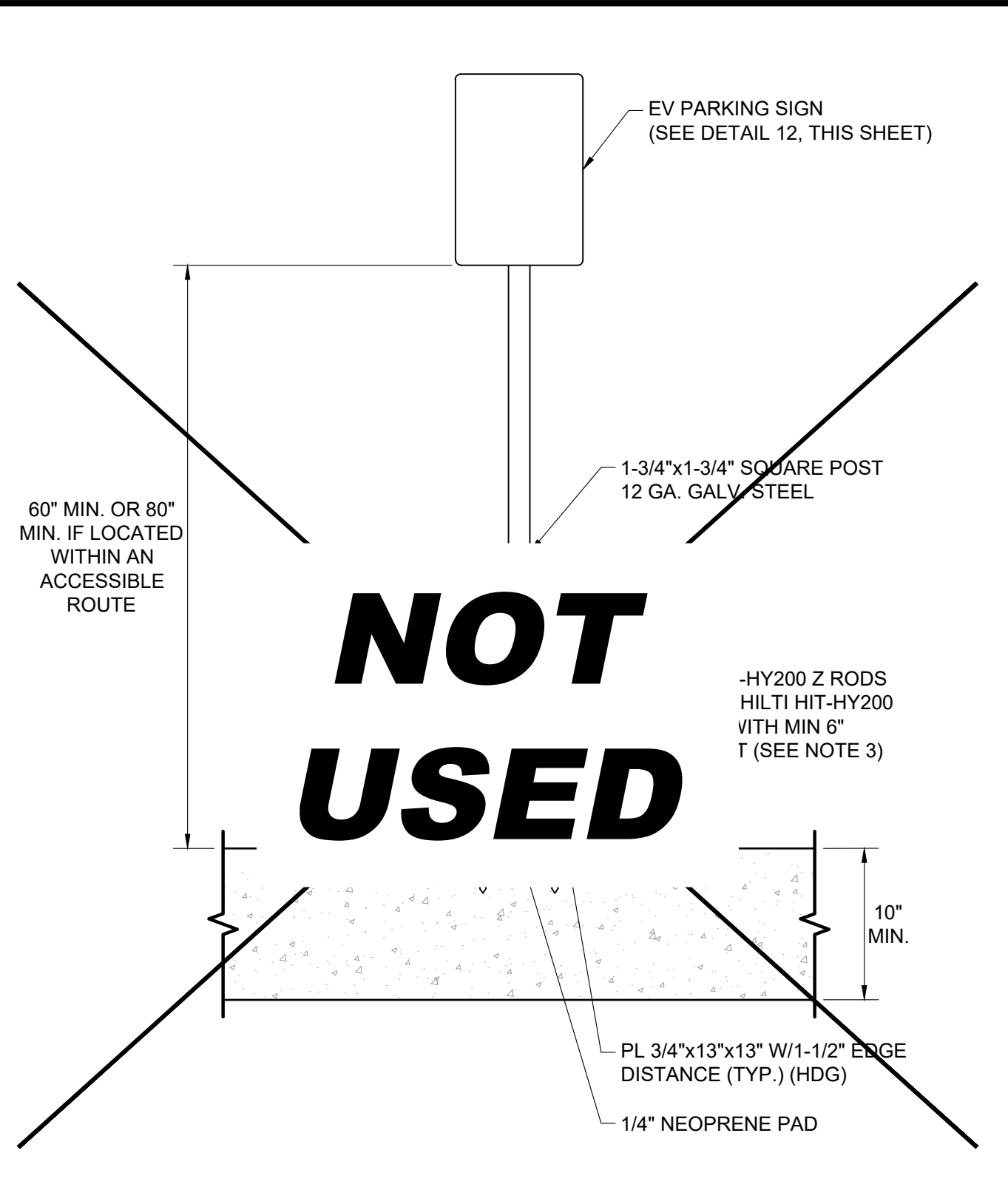

**POST INSTALLED SIGN POST** SCALE N.T.S. 10

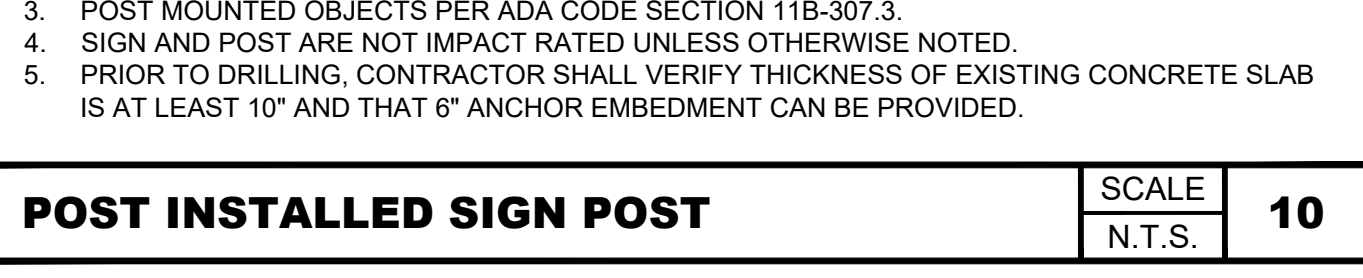

**FOR REFERENCE ONLY, DESIGNED AND PROVIDED BY OTHERS.**

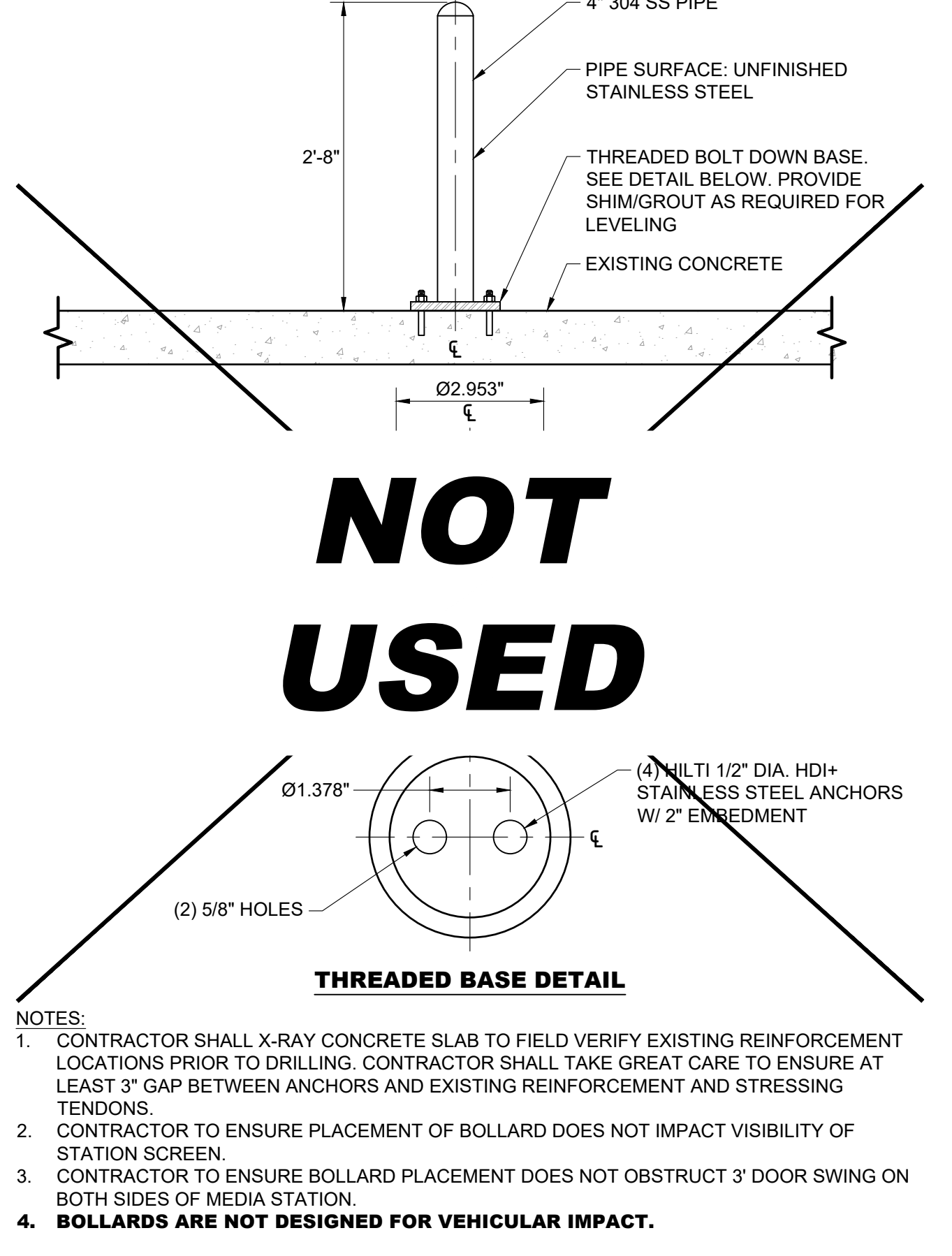

**4" DETERRENT BOL. W/ THREADED BASE** SCALE N.T.S. 14

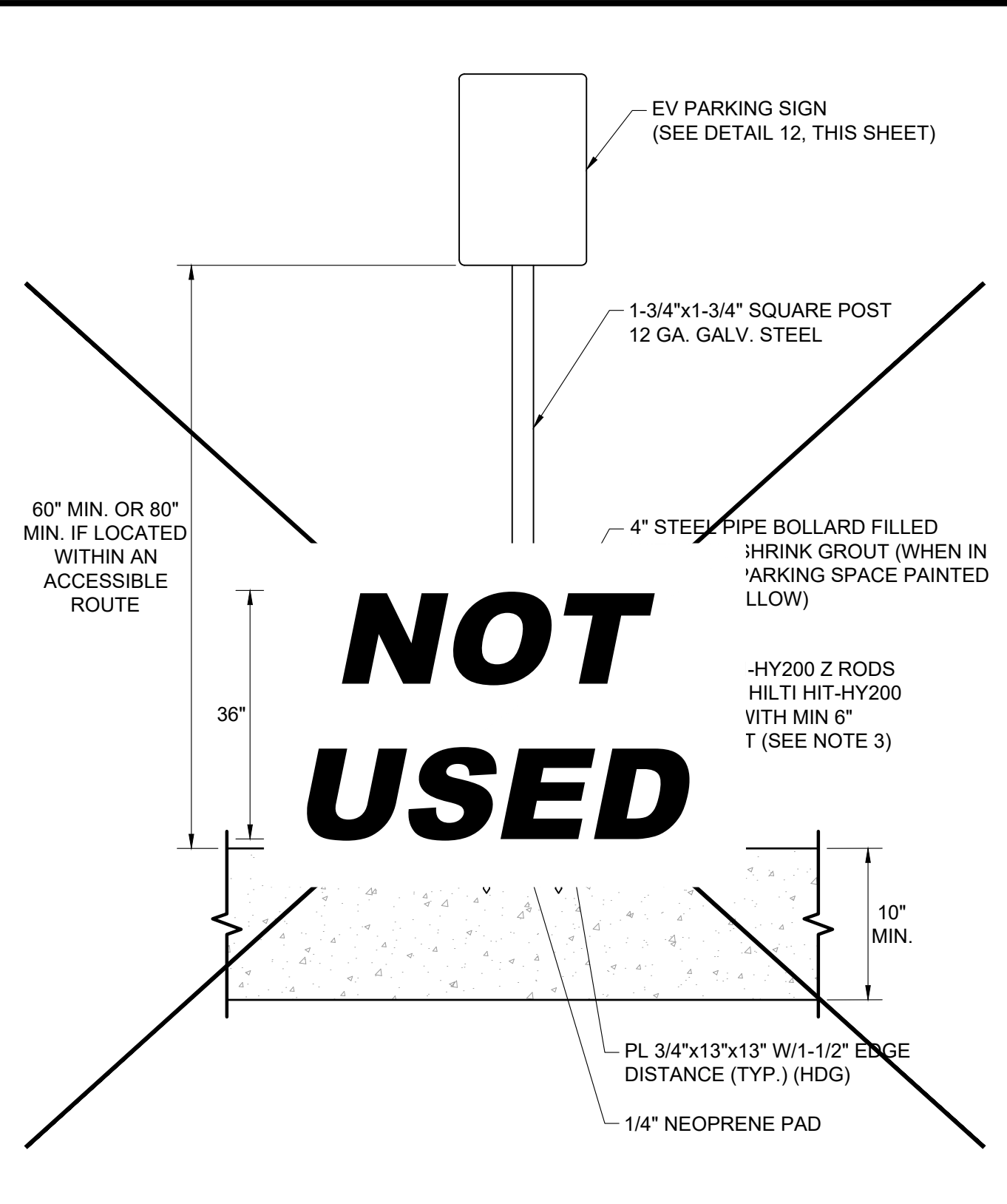

**POST INSTALLED SIGN POST W/BOL.** SCALE N.T.S. 11

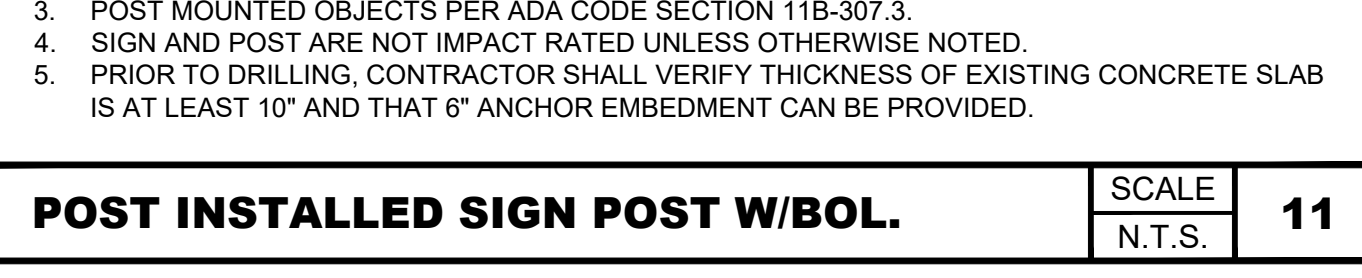

**FOR REFERENCE ONLY, DESIGNED AND PROVIDED BY OTHERS.**

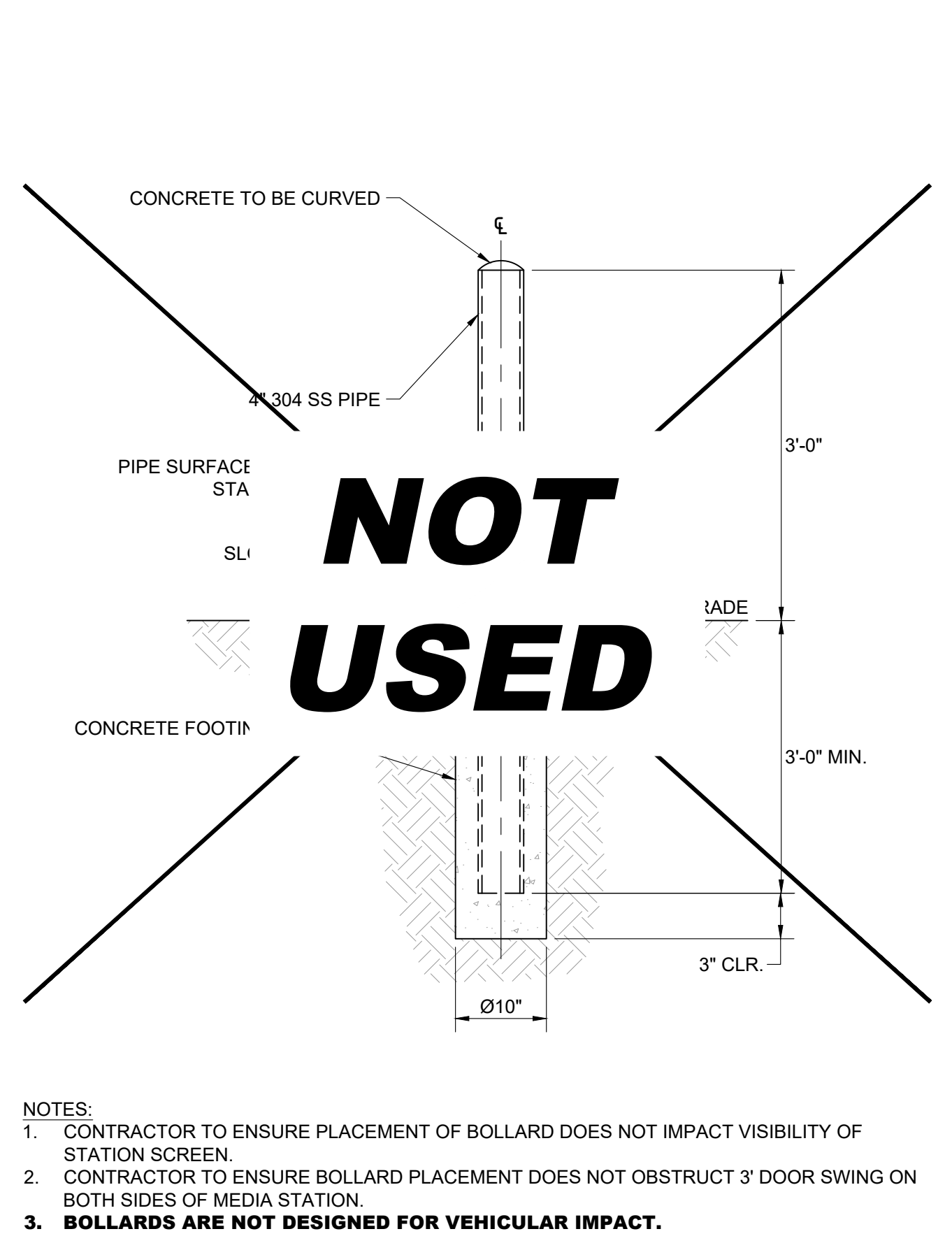

**4" DETERRENT BOLLARD** SCALE N.T.S. 15

**VOLTA**  
155 DE HARO STREET  
SAN FRANCISCO, CA 94103

**Kimley Horn**  
1 N LEXINGTON AVE, SUITE 505  
WHITE PLAINS, NY 10601  
Main: 914.368.9200 | www.kimley-horn.com  
© 2021 Kimley-Horn and Associates, Inc.

REV	DATE	DESCRIPTION	BY
1	03/03/2021	CD90s	TAS
2	05/05/2021	CD100s	TAS
3	07/21/2021	CD100s	TAS

ISSUE DATE  
**05/05/2021**

ISSUED FOR  
**PERMIT**

IT IS A VIOLATION OF LAW FOR ANY PERSON, UNLESS THEY ARE ACTING UNDER THE DIRECTION OF A LICENSED PROFESSIONAL ENGINEER, TO ALTER THIS DOCUMENT.

**STOP & SHOP #2604 TORRINGTON**  
931 TORRINGTON STREET  
TORRINGTON, CT 06790

SHEET TITLE  
**SITE DETAILS**

SHEET NUMBER  
**C3-01**

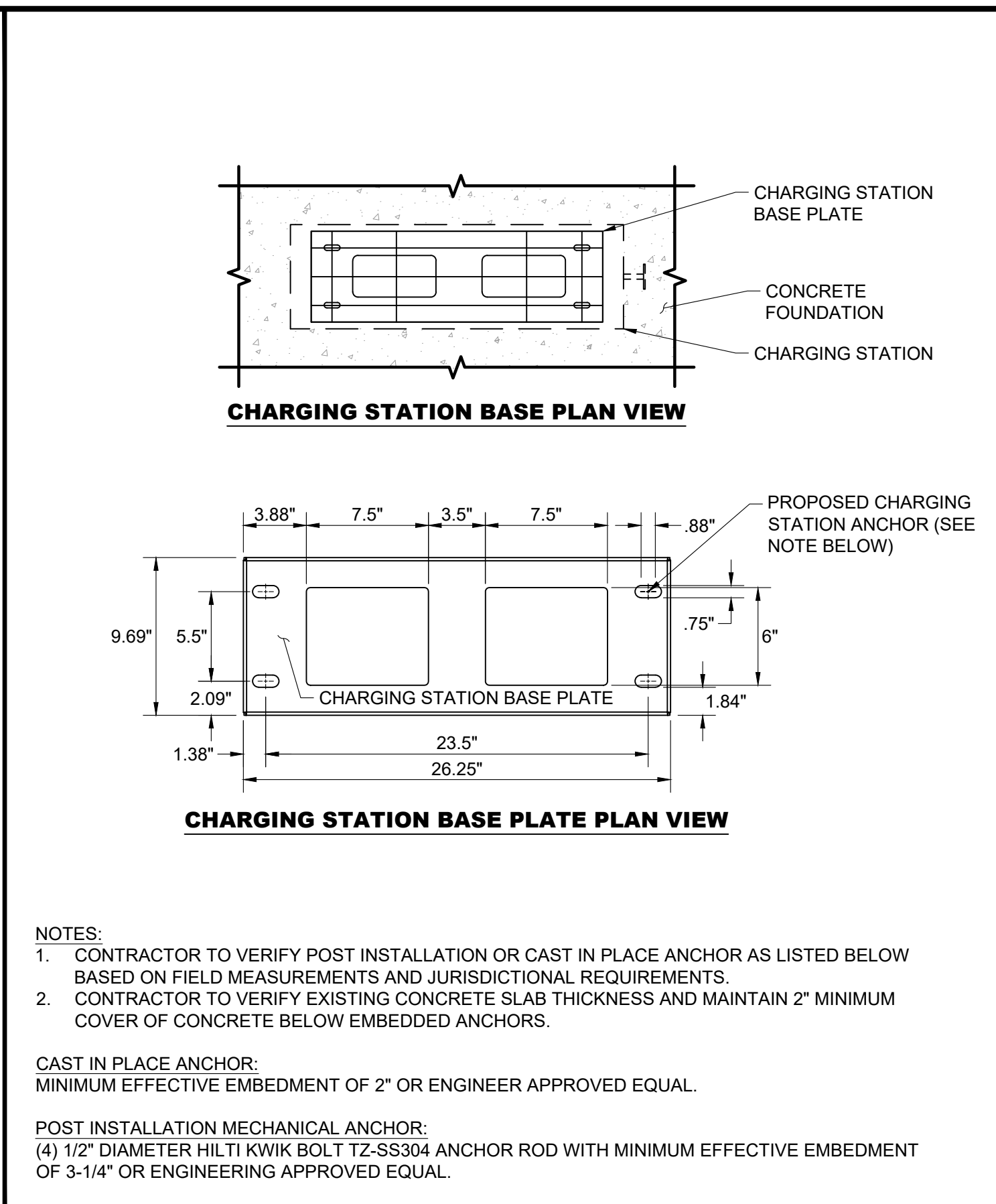
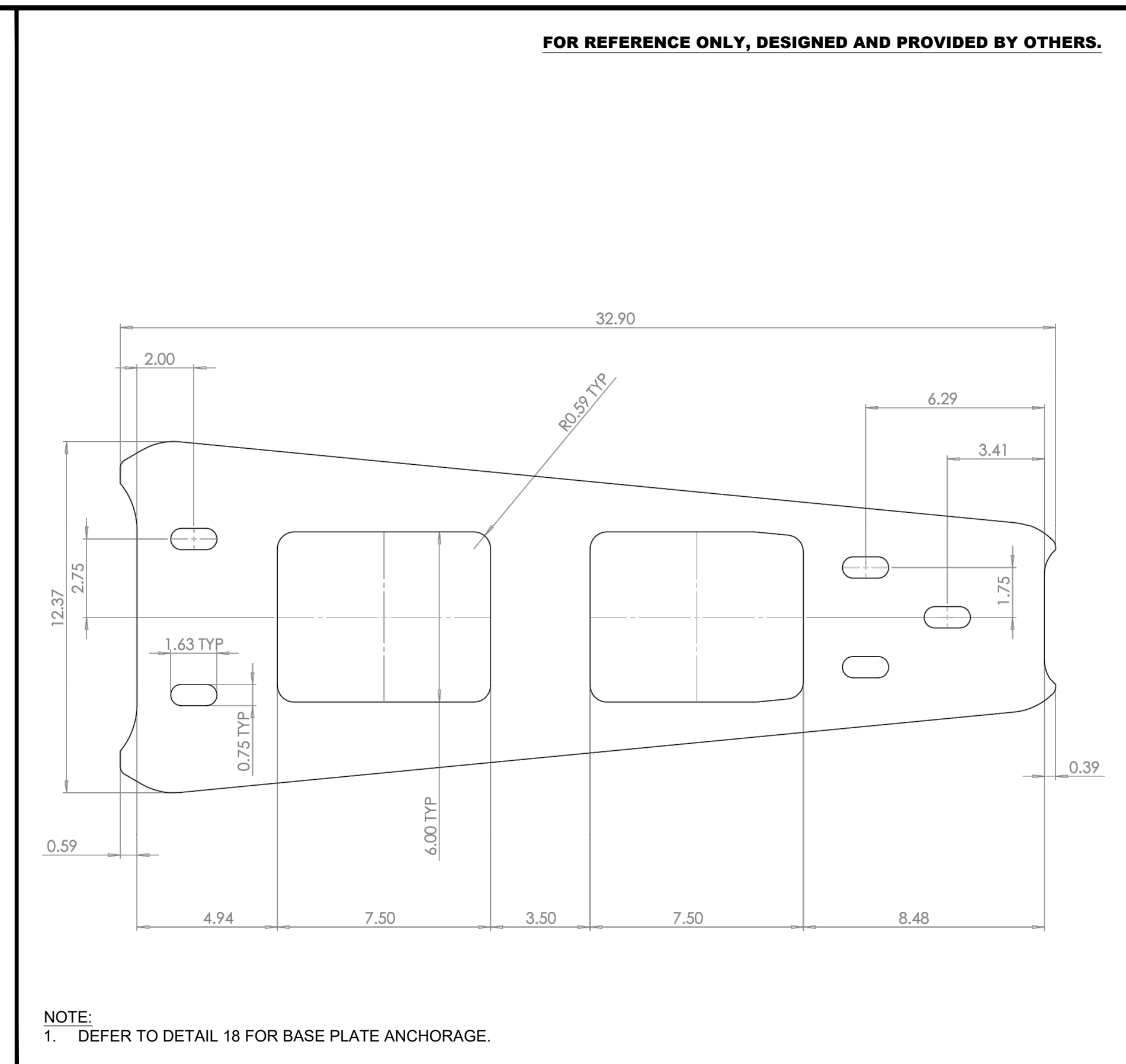
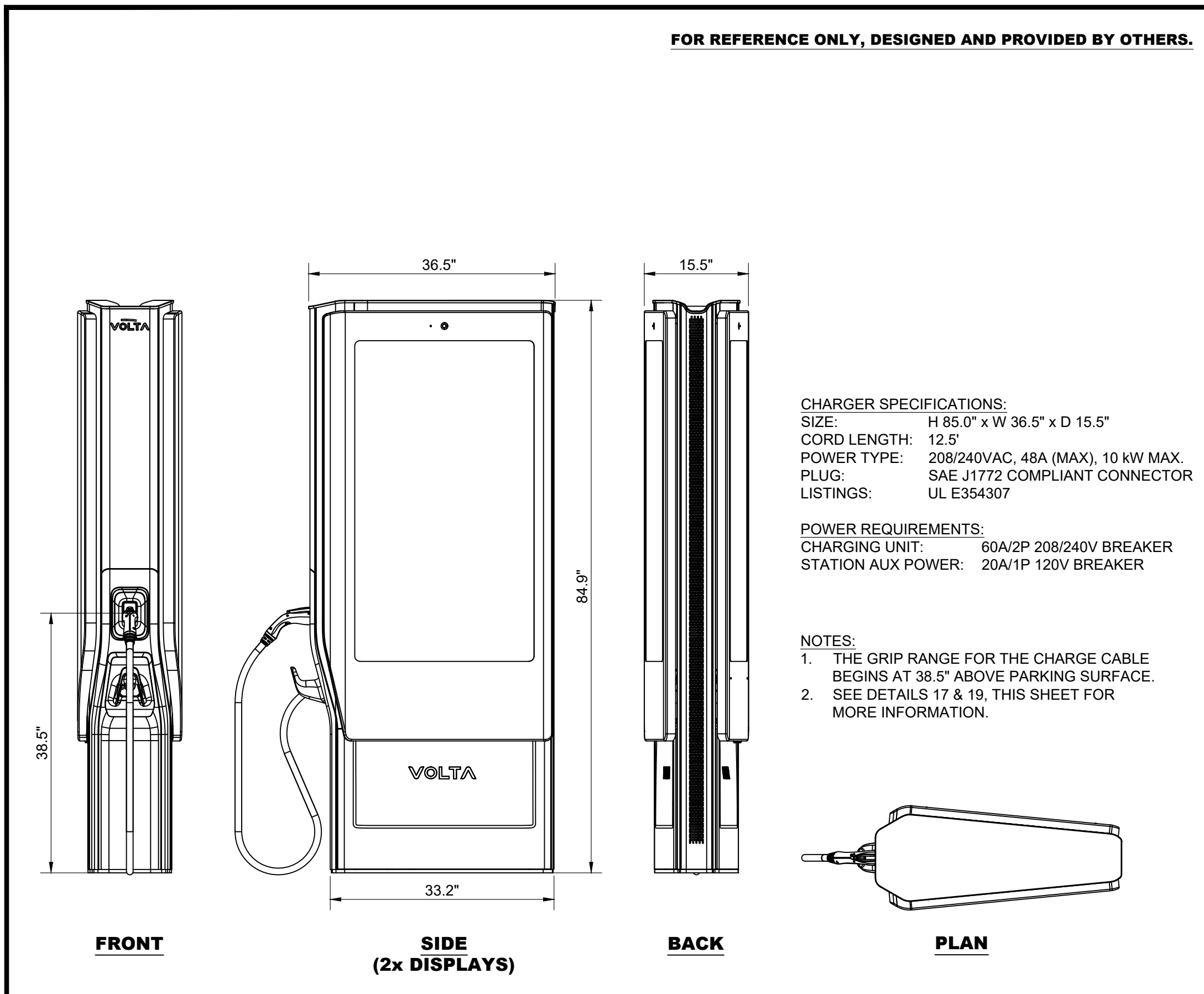

**VOLTA V4 L2 EVCS**      SCALE N.T.S.      **16**

**VOLTA V4 BASE PLATE**      SCALE N.T.S.      **17**

**VOLTA BASE PLATE ANCHORAGE**      SCALE N.T.S.      **18**

**FOR REFERENCE ONLY, DESIGNED AND PROVIDED BY OTHERS.**

### Level 2 Media Station

Volta Charging is driving the transition to clean electric transportation by transforming properties with electric vehicle charging. No longer will people drive to fuel, but fuel where they drive.

Volta's turn-key electric vehicle charging is tailored to each location's needs and desired customer experience to increase traffic and customer engagement. Our fully integrated EV chargers include high-impact digital media screens that provide properties with branding and messaging as well as additional revenue opportunities.

**Charger Specs**

- Output power: 10 kW max (AC)
- Safety certification: UL 2202

**Power Requirements**

- Input voltage: 208 - 240 VAC
- Output voltage: 208 - 240 VAC
- Circuit size: 60A/2P, 208/240 breaker
- Network connectivity: Cell connection or LAN access

**Display Screen Specs**

- Size: 55" outdoor LED back light system x2
- Picture: Full HD 1080p resolution
- Power requirements: 20A/1P, 120V breaker
- File type: JPEG or PNG

**Installation Requirements**

- Foundation req: 36"L x 36"W x 36"D
- Conduit diameter: 1.5" min per station approx\*
- \*Separate conduit for communication may be required

**Example Level 2 Media Foundation Plans**

voltacharging.com      770-0002-A

**FOR REFERENCE ONLY, DESIGNED AND PROVIDED BY OTHERS.**

**eMOBILITY SOLUTIONS**

### eClick Data sheet

**General and electrical specifications**

Charging power	up to 10.4kW / 12kW (up to 50A)
Mains input power	208 Volt AC WYE system, 50A, 10.4kW 240 Volt AC split phase, 50A, 12kW 240 Volt AC Center Tap Delta, 50A, 12kW
Output power to eBox	208 Volt AC WYE system, 50A, 10.4kW 240 Volt AC split phase, 50A, 12kW 240 Volt AC Center Tap Delta, 50A, 12kW maximum output depends on local distribution grid
Storage temperature	-22°F to +176°F (-30°C to +80°C)
IP	I
Max line cross section	Max supply line (top or bottom entry): AWG (10 mm <sup>2</sup> )
Certifications	UL and FCC (tested and confirmed by a certified body)
Packaging dimensions (W x D x H)	1'-8 1/4" x 8-4/5" x 3'-0 1/2" (315 mm x 225 mm x 75 mm)

**Recommended additional accessories**

Short circuit / overload protection	Circuit breaker required according to national law and regulations
Installed in sub-distribution per charge port	Electrical installer to choose correct circuit breaker depending on grid type and power.

**Broadband TelCom Power, Inc.**  
 1719 S. Grand Ave.  
 Santa Ana, CA 92705, USA  
 sales@btcpower.com  
 www.btcpower.com

**FOR REFERENCE ONLY, DESIGNED AND PROVIDED BY OTHERS.**

**eMOBILITY SOLUTIONS**

### eBox professional Data sheet

**General and electrical specifications**

Charging power	up to 10.4kW (WYE) / up to 12kW (split phase/center tap delta) (up to 50A)
Applications	Protected internal areas; unprotected exterior areas exposed to rain and direct sunlight
Enclosure Rating	Type 3S
Operating temperature	-22°F to 122°F (-30°C to +50°C) full load
Storage temperature	-22°F to +176°F (-30°C to +80°C)
Air humidity	5% to 95% as defined under IEC 61851-1 Ed.3/EN 61851-1 (2017)
Max altitude above sea level	Max 6,500 ft (2,000 m) (air pressure: 860 hPa to 1,050 hPa)
UV protection	Outdoors (BT)
Housing material	Lexan® EXL9330 (copolymer) Flame class rating V0 (UL94)
Protection category (impact strength)	IK10 as defined under IEC 62262-2:2002
Weight (without eClick)	6.4 kg
Number of charging ports	1
Plug assembly	Type 1 plug as defined under SAE J1772™, plug compartments on eBox, shutter
Cable length	24'-7 1/4" (7.5 m)
Backend protocol	eOperate using LG2WAN for business applications and eHome using OCPP 2.0 for residential applications
Input power from eClick	up to 10.4kW (WYE) / up to 12kW (split phase / center tap delta) (up to 50A)
Output power	up to 10.4kW (WYE) / up to 12kW (split phase / center tap delta) (up to 50A)
Electrical Protection Class	I
Standby power	6 W
Charging mode	Mode 3 (IEC 61851)
Vehicle communication	Charging current controlled via PWM pilot signal (IEC 61851-1:2017)
Alternative vehicle communication	ISO 15118 ready via PLC
User protection: integrated	Integrated AC/DC sensitive GFCI, tripping at: 20 mA rms for AC and for DC according to UL2231 (ESD/Surge/Burst)
Integrated overvoltage protection	LED ring for charging status; 2 status LEDs: authentication / RFID, vehicle ID; 1 status LED as touch button: Bluetooth
Measured consumption	Current and voltage measured by eBox, power and energy provided with 99% accuracy
Direct communication	Bluetooth Class 1 and 2 (power level)
Backend link	eHome (eCharge+ app): WLAN with 2.4 GHz b/g/n with WPA2 (saerl gain, frequency-dependent, max 4.6 dB) or LAN or eOperate: SIM-card (frequency- and direction-dependent, max 4.4 dB (saerl gain))
Authentication / activation	Free charging: eCharge+ app (smartphone app for iOS / Android™) from contracted providers or Direct Payment (credit card / PayPal), Direct Payment via web access
Plug&Charge (ISO 15118)	Yes
RFID authentication	Yes, protocols: MIFARE Classic (card and chip) as defined under ISO 14443A, Type V (ISO/IEC 15693/Vicinity)
Charging port number	Charge port number lasered on shutter

Remark: Android is a trademark of Google LLC.

**FOR REFERENCE ONLY, DESIGNED AND PROVIDED BY OTHERS.**

**eMOBILITY SOLUTIONS**

### eBox professional Data sheet

The eBox professional is a modern, leading-edge charging solution for electric vehicles. It can be used easily and quickly for charging up to 12kW of power. It presents a large number of ports and authentication options. The eBoxes can be mounted in the eClick on a wall. The eBox professional is available with a Type 1 plug and cable.

**NOT USED**

**Key features**

- Charging (up to 12 kW)
- Charging status displayed by 3 LEDs and LED ring
- Facilities for authenticating and paying for charging processes by app, RFID card or ISO 15118
- LTE / 3G / 2G communication with eOperate or WLAN, LAN with eCharge+ app
- Commissioning: simply clicking the eBox on the eClick and connect via Bluetooth with the smartphone

**Certificates**

UL US      FC

**VOLTA V3 EVCS CUT SHEET**      SCALE N.T.S.      **19**

**ECLICK DATA CUT SHEET**      SCALE N.T.S.      **20**

**EBOX DATA CUT SHEET**      SCALE N.T.S.      **21**

**EBOX DATA CUT SHEET**      SCALE N.T.S.      **22**

**VOLTA**

155 DE HARO STREET  
SAN FRANCISCO, CA 94103

**Kimley Horn**

1 N LEXINGTON AVE, SUITE 505  
WHITE PLAINS, NY 10601  
Main: 914.368.9200 | www.kimley-horn.com  
© 2021 Kimley-Horn and Associates, Inc.

REV	DATE	DESCRIPTION	BY
1	03/03/2021	CD90s	TAS
2	05/05/2021	CD100s	TAS
3	07/21/2021	CD100s	TAS

ISSUE DATE  
**05/05/2021**

ISSUED FOR  
**PERMIT**

IT IS A VIOLATION OF LAW FOR ANY PERSON, UNLESS THEY ARE ACTING UNDER THE DIRECTION OF A LICENSED PROFESSIONAL ENGINEER, TO ALTER THIS DOCUMENT.

**STOP & SHOP #2604  
TORRINGTON**

**931 TORRINGTON STREET  
TORRINGTON, CT 06790**

SHEET TITLE  
**SITE DETAILS**

SHEET NUMBER  
**C3-02**

NOTE: THE ORIGINAL SIZE OF THIS PLAN IS 24" X 36". SCALE RATIO IS NOT VALID FOR REDUCED OR ENLARGED SHEET SIZES

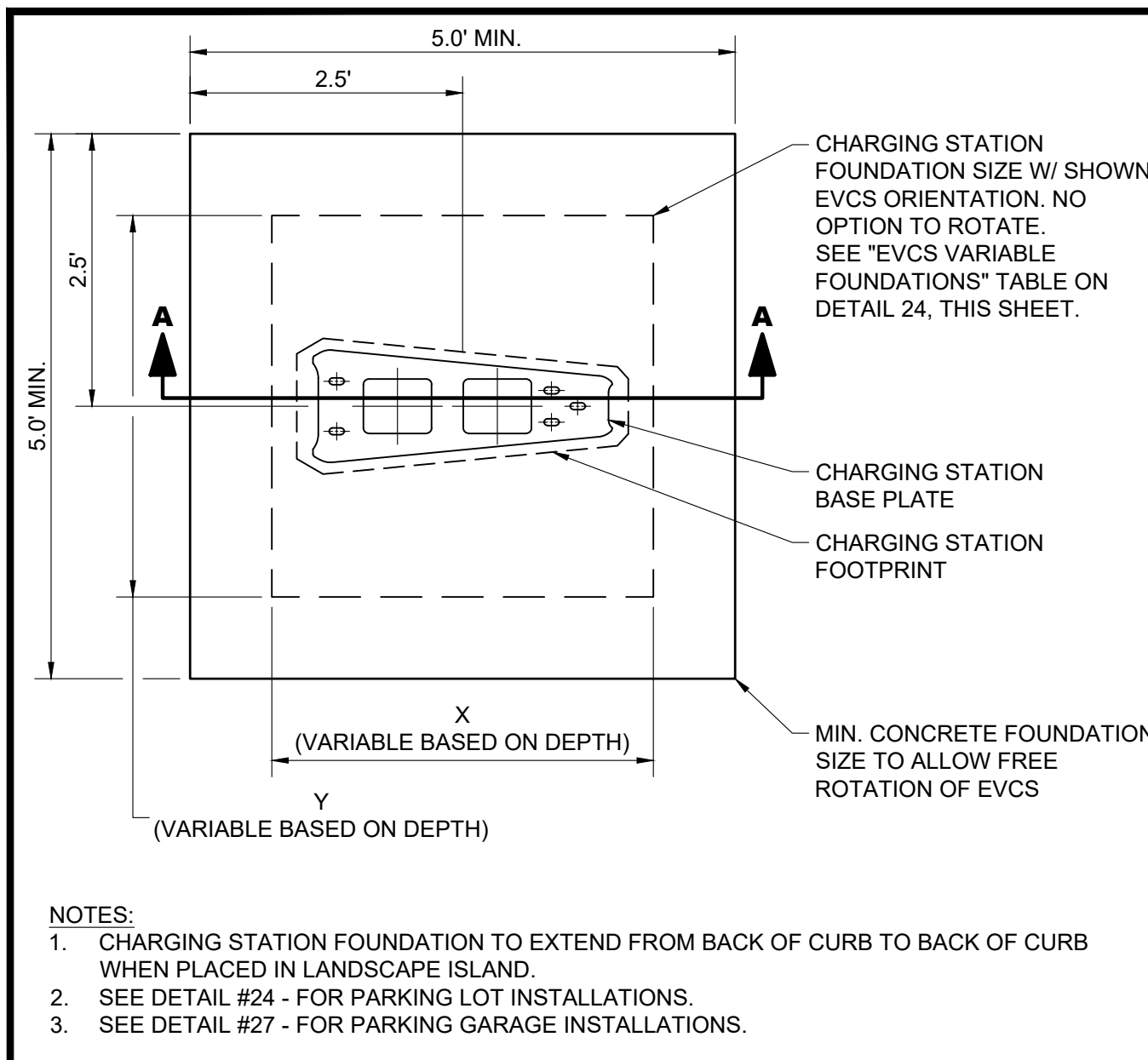

NOTES:

- CHARGING STATION FOUNDATION TO EXTEND FROM BACK OF CURB TO BACK OF CURB WHEN PLACED IN LANDSCAPE ISLAND.
- SEE DETAIL #24 - FOR PARKING LOT INSTALLATIONS.
- SEE DETAIL #27 - FOR PARKING GARAGE INSTALLATIONS.

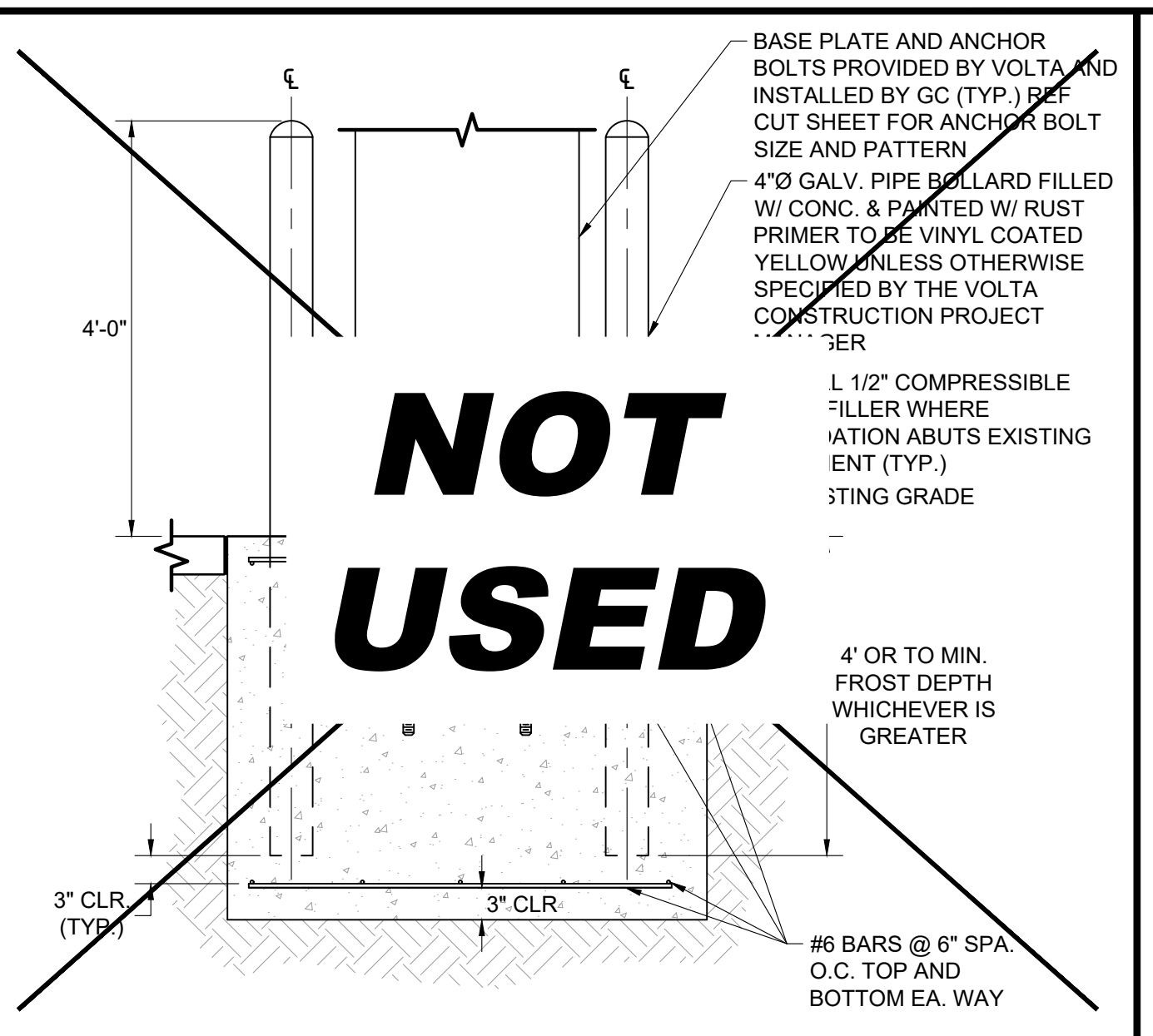
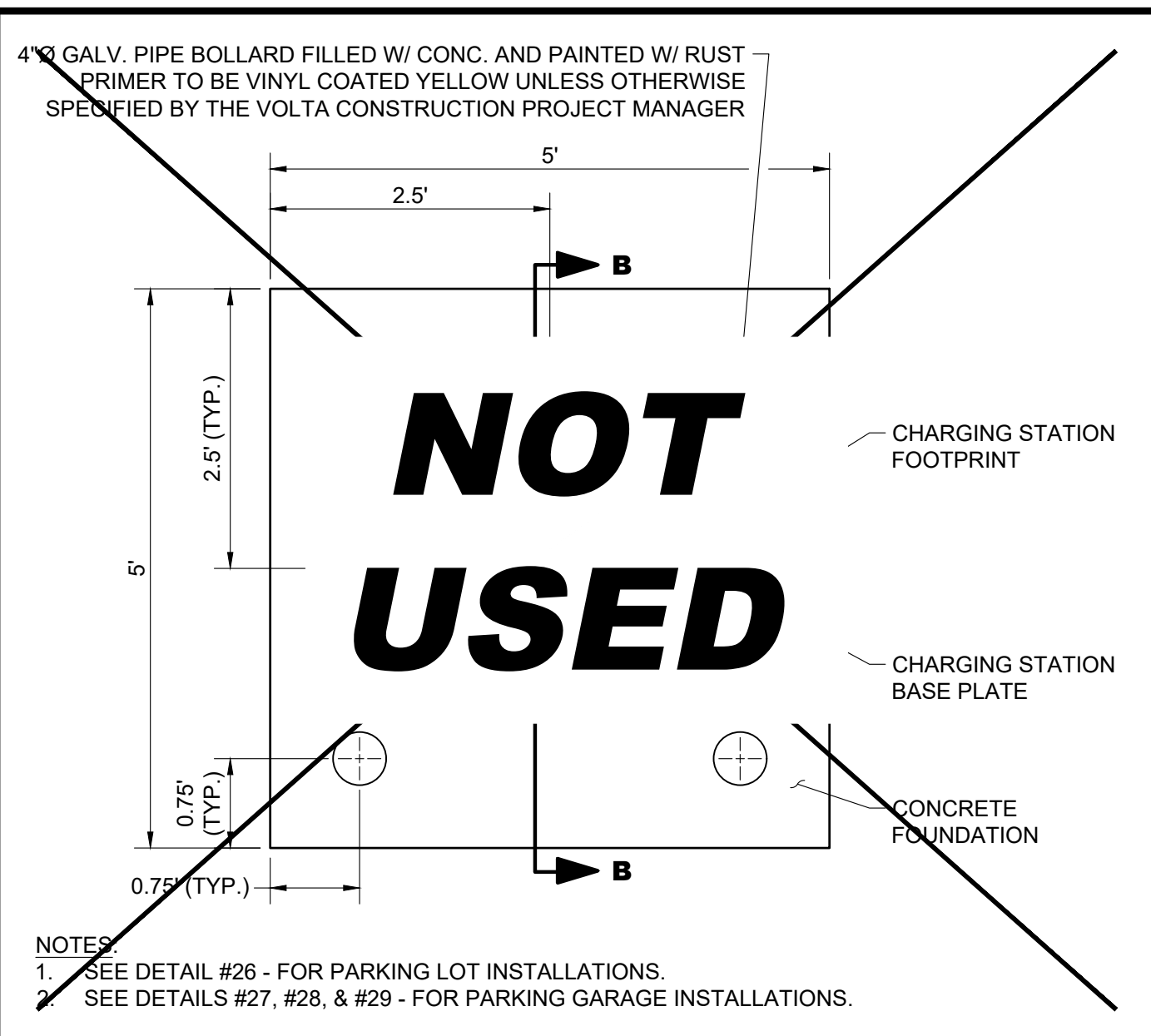
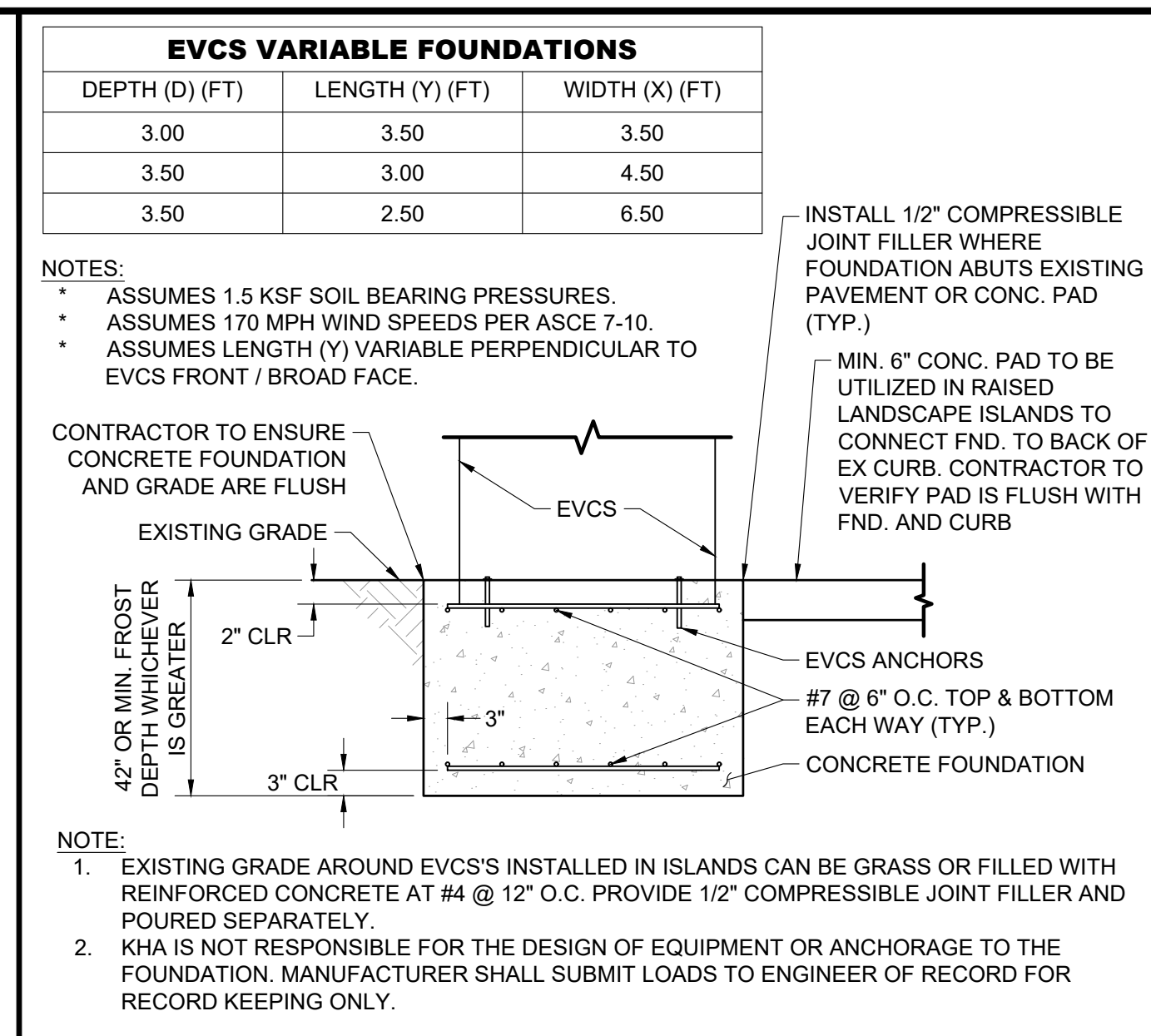

V4 EVCS FOUNDATION SCALE N.T.S. 23

V4 EVCS FOUNDATION SECTION A-A SCALE N.T.S. 24

V4 EVCS FOUNDATION W/ 4" PIPE BOL. SCALE N.T.S. 25

EVCS FOUNDATION SECTION B-B SCALE N.T.S. 26

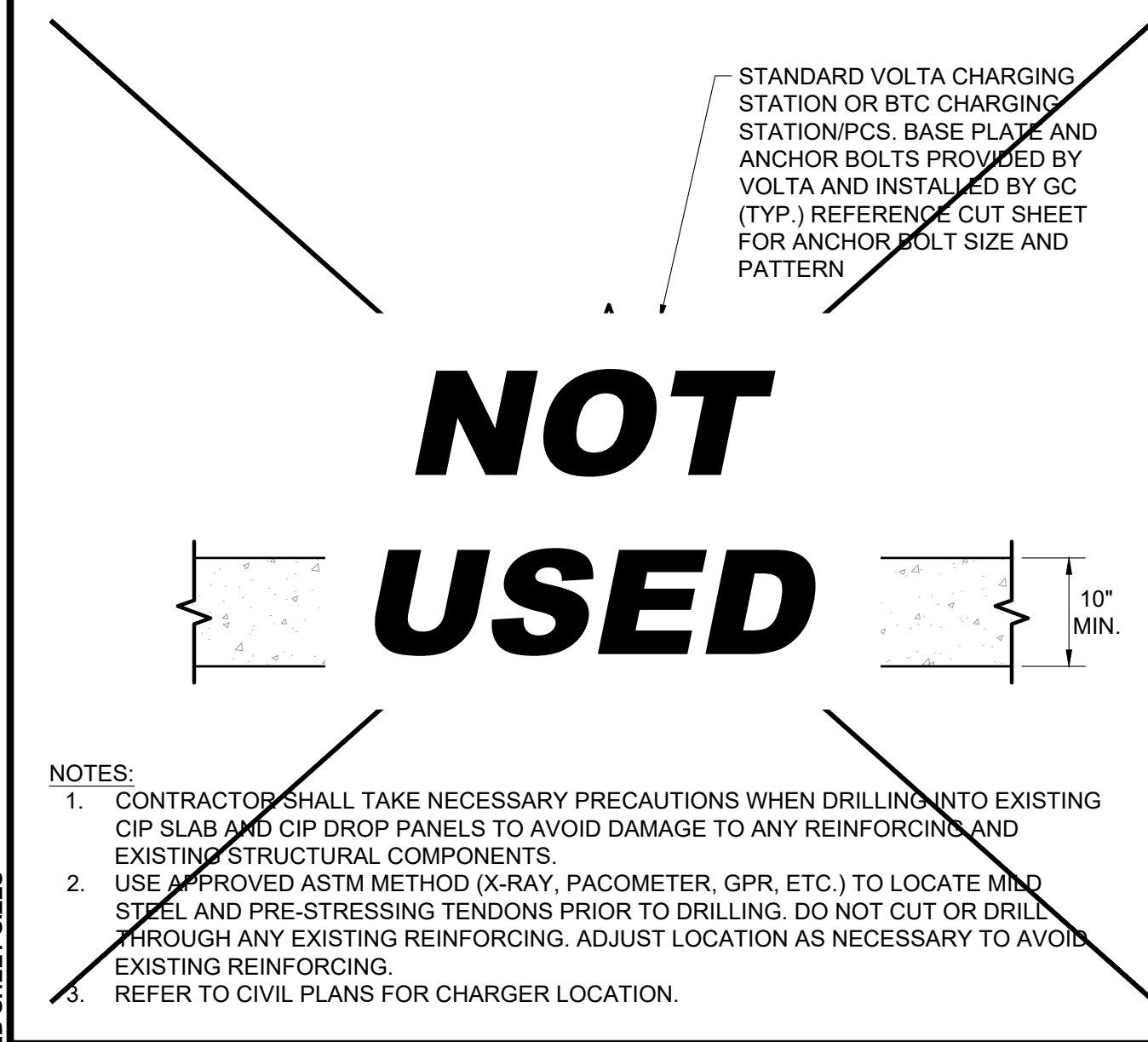

POST INSTALLED AT ELEVATED SLAB EVCS SCALE N.T.S. 27

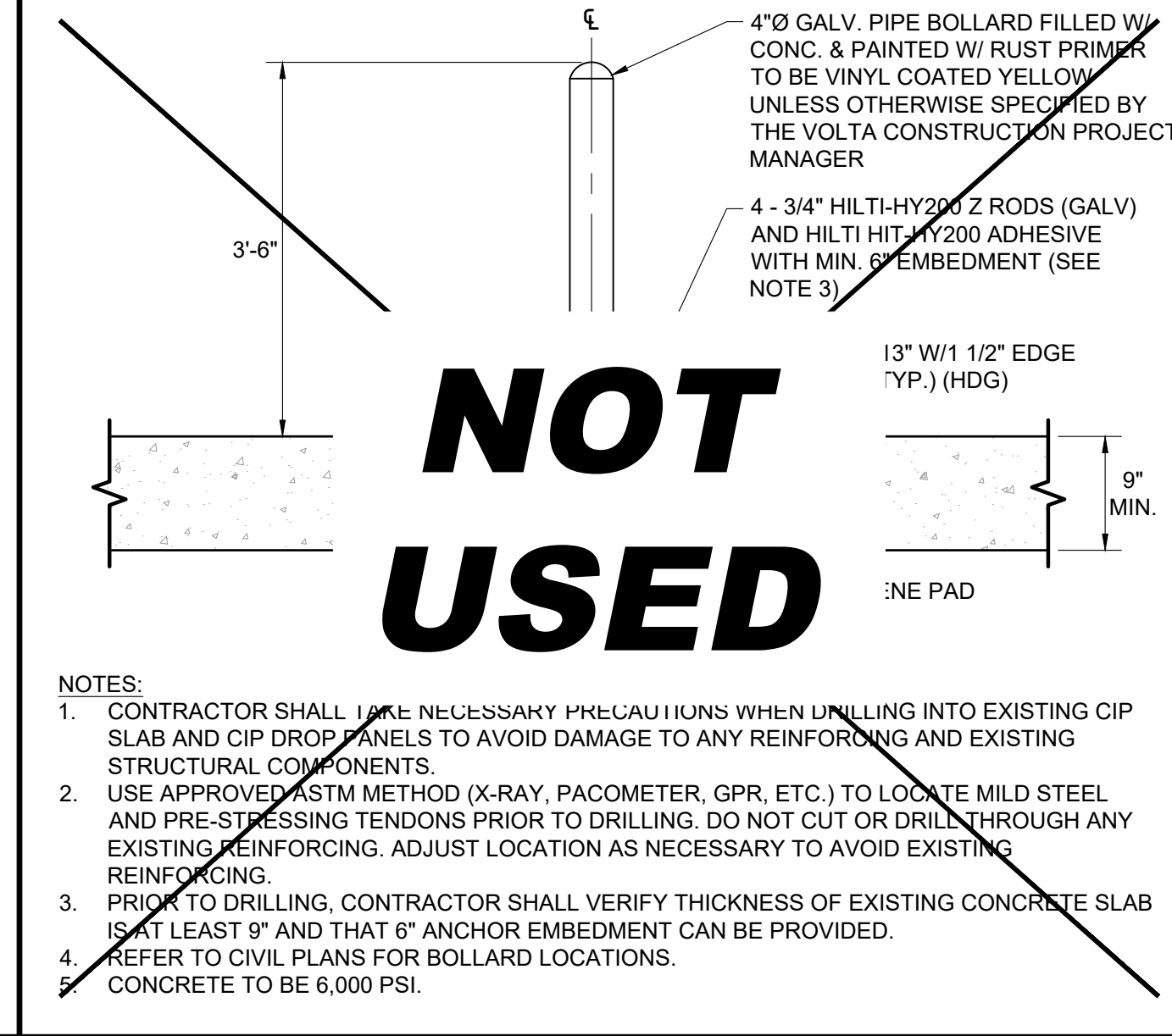

POST INSTALLED BOLLARD SCALE N.T.S. 28

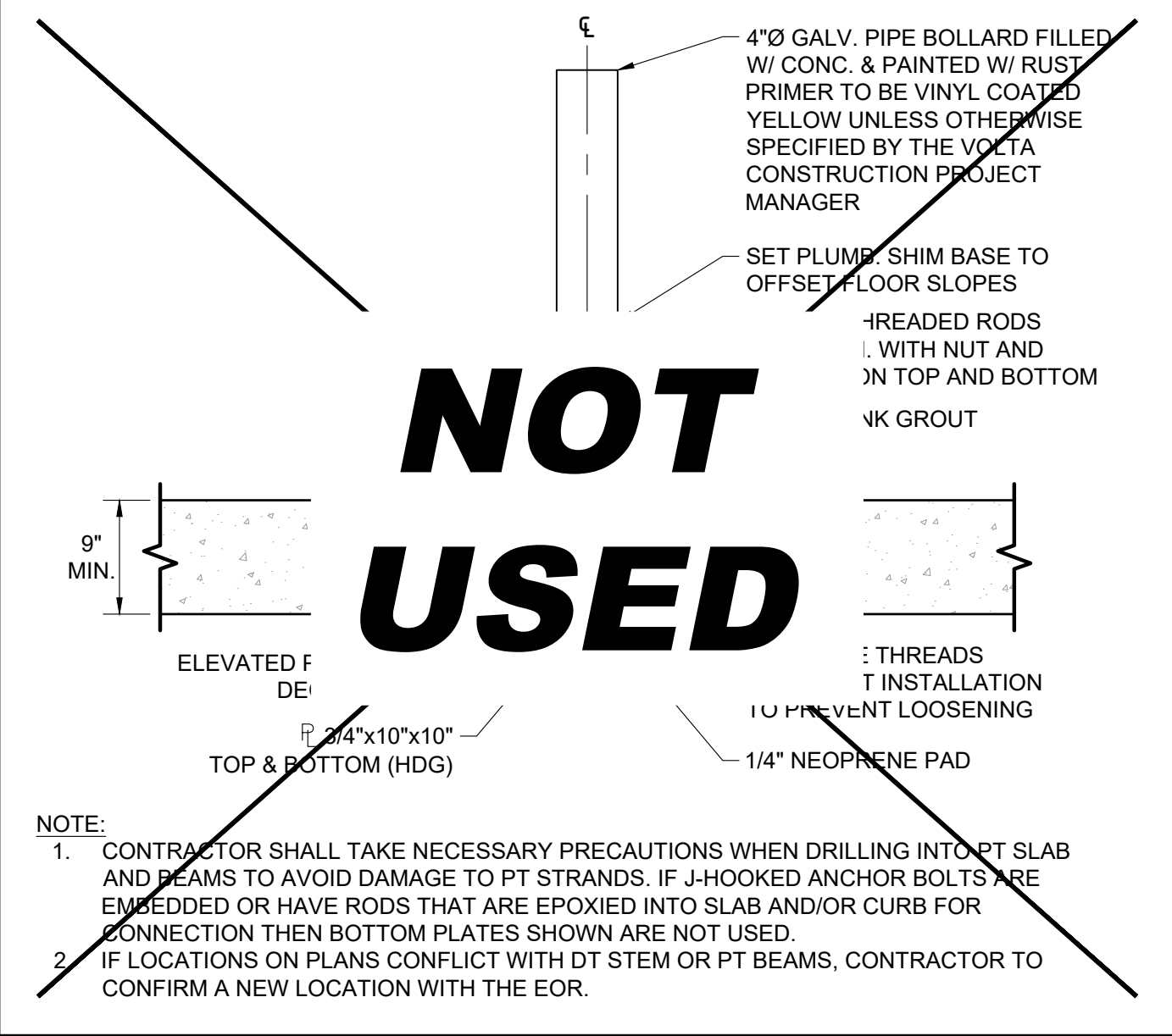

BOLLARD CONNECTION-SLAB MOUNT SCALE N.T.S. 29

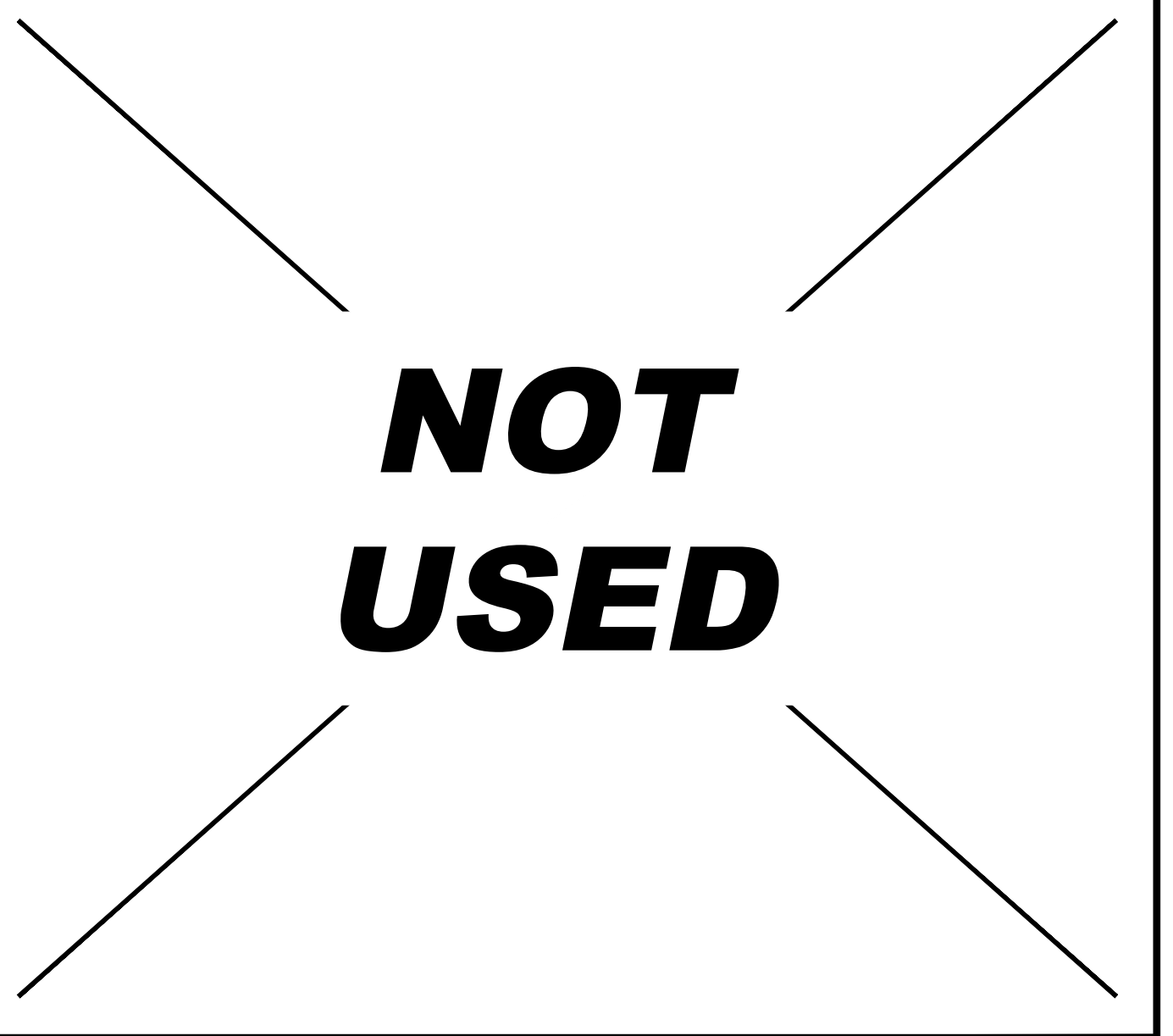

NOT USED SCALE N.T.S. 30

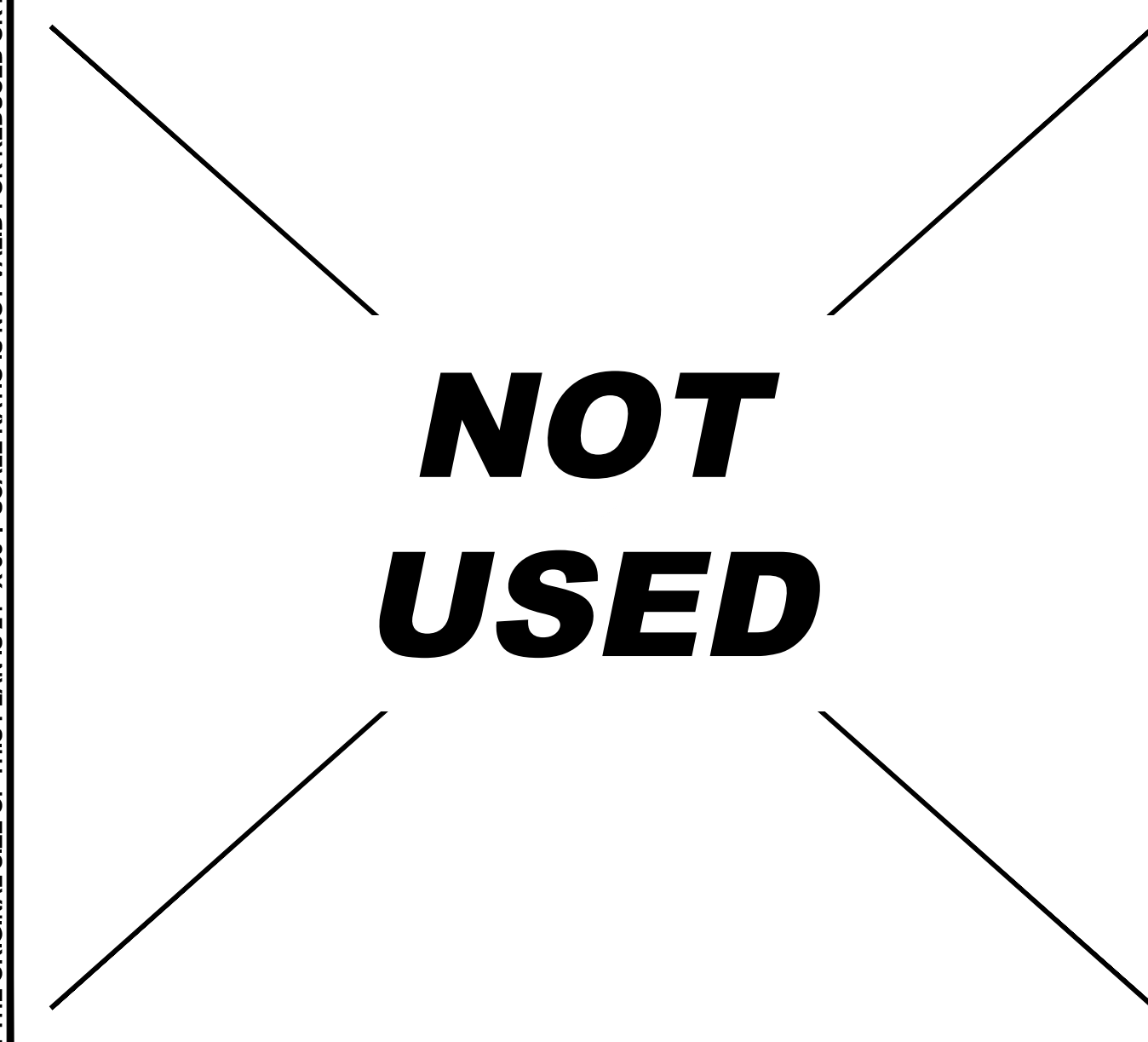

NOT USED SCALE N.T.S. 31

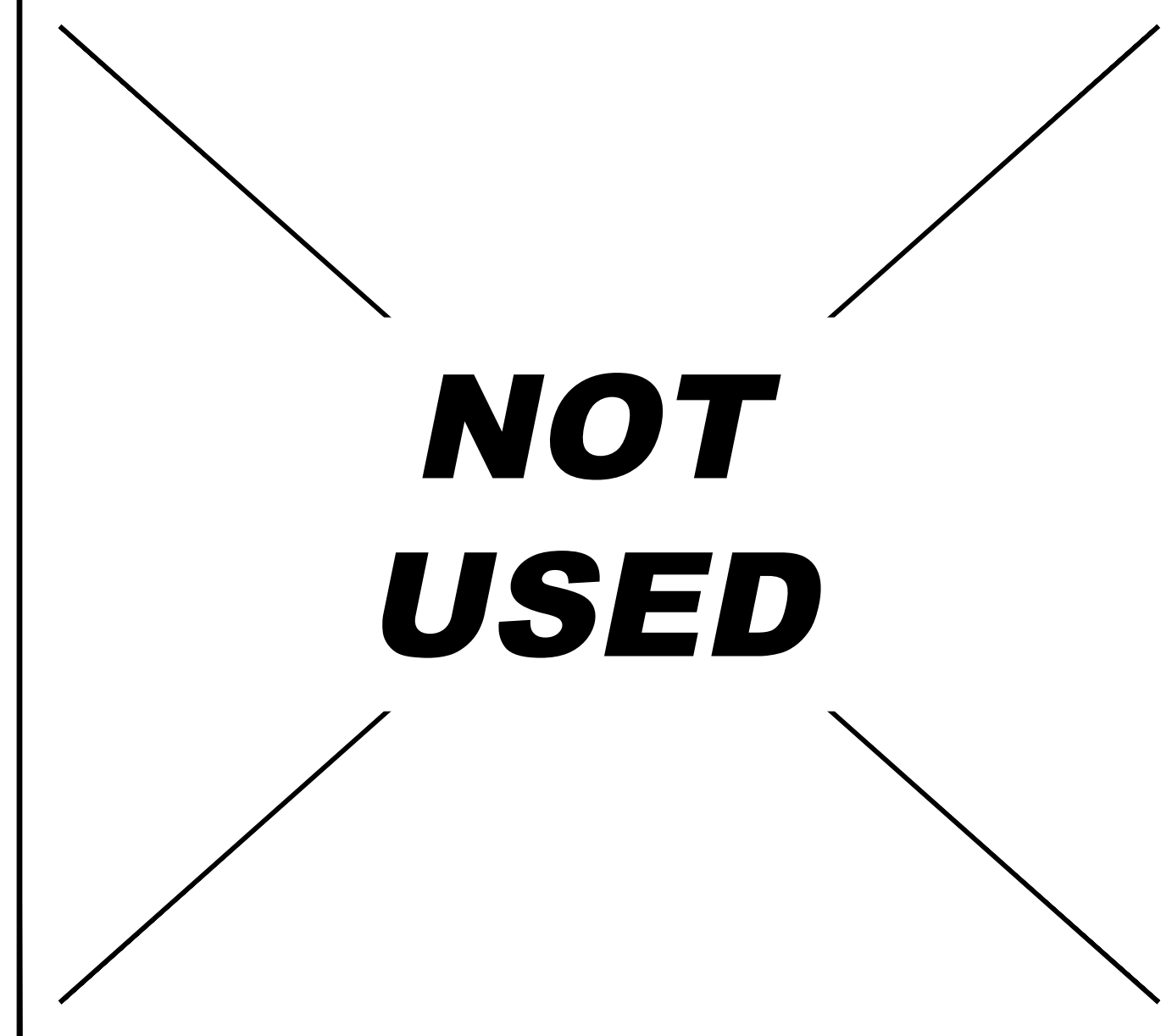

NOT USED SCALE N.T.S. 32

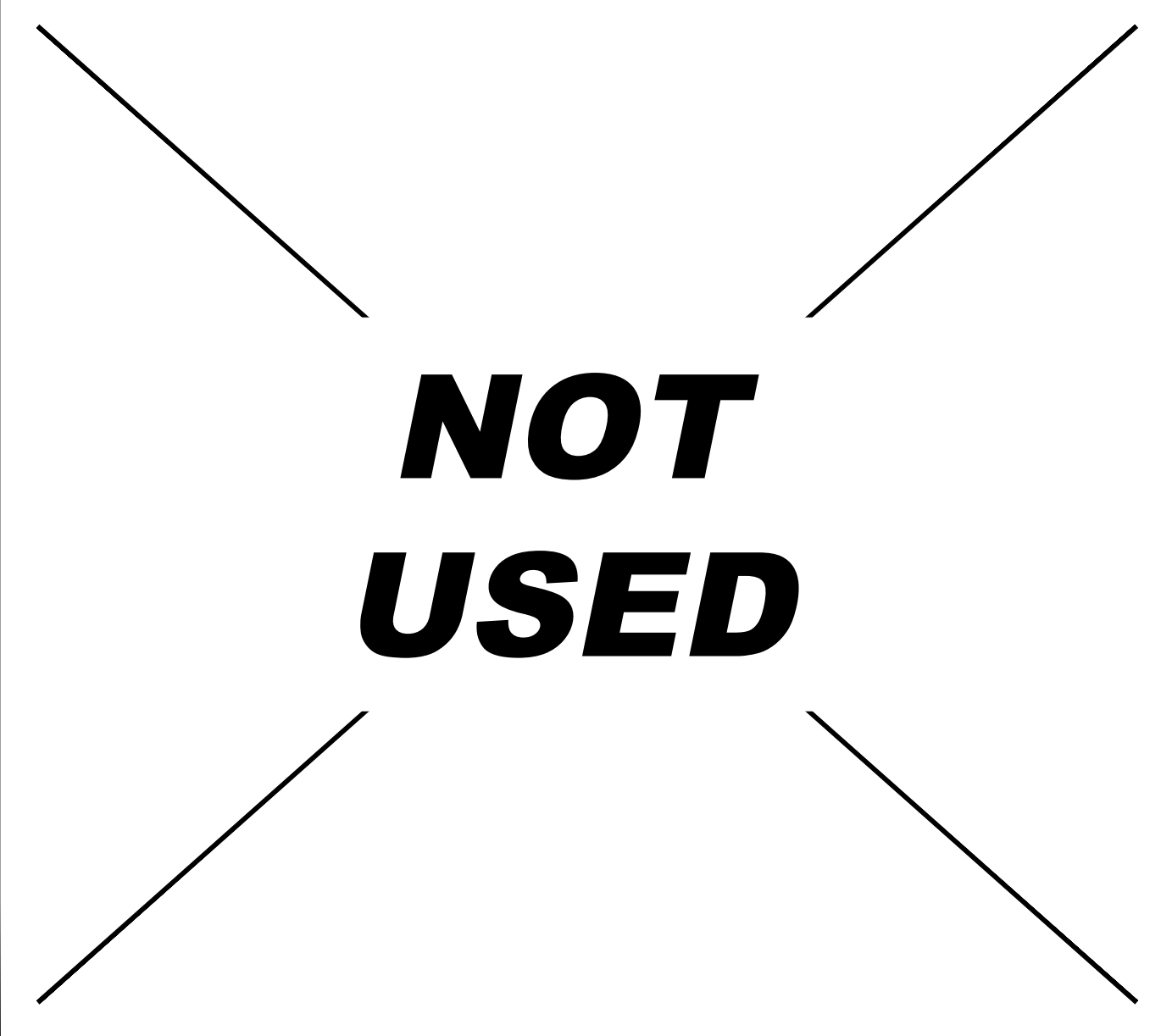

NOT USED SCALE N.T.S. 33

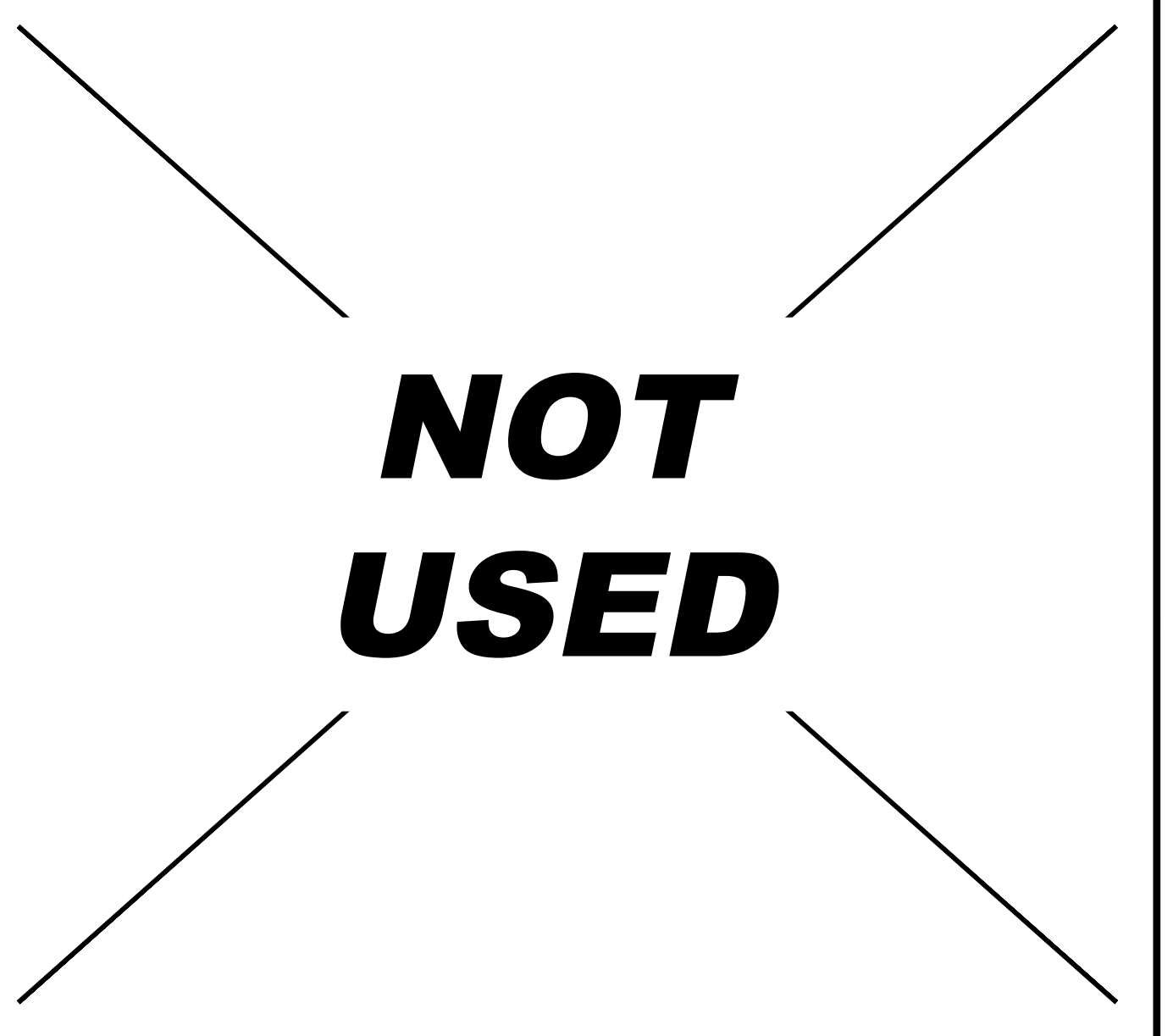

NOT USED SCALE N.T.S. 34

**VOLTA**

155 DE HARO STREET  
SAN FRANCISCO, CA 94103

**Kimley-Horn**

1 N LEXINGTON AVE, SUITE 505  
WHITE PLAINS, NY 10601  
Main: 914.368.9200 | www.kimley-horn.com  
© 2021 Kimley-Horn and Associates, Inc.

REV	DATE	DESCRIPTION	BY
1	03/03/2021	CD90s	TAS
2	05/05/2021	CD100s	TAS
3	07/21/2021	CD100s	TAS

ISSUE DATE  
**05/05/2021**

ISSUED FOR  
**PERMIT**

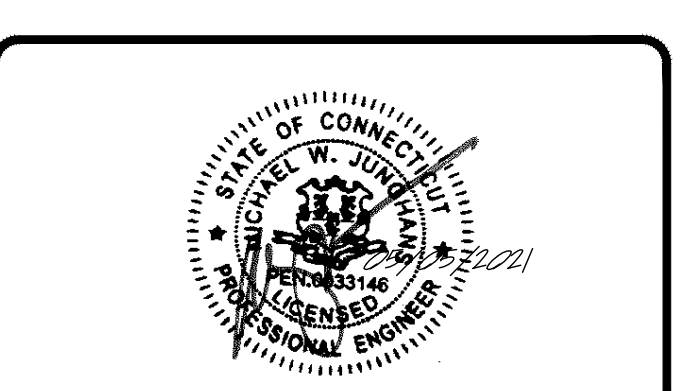

IT IS A VIOLATION OF LAW FOR ANY PERSON, UNLESS THEY ARE ACTING UNDER THE DIRECTION OF A LICENSED PROFESSIONAL ENGINEER, TO ALTER THIS DOCUMENT.

**STOP & SHOP #2604 TORRINGTON**

931 TORRINGTON STREET  
TORRINGTON, CT 06790

SHEET TITLE  
**SITE DETAILS**

SHEET NUMBER  
**C3-03**

NOTE: THE ORIGINAL SIZE OF THIS PLAN IS 24" X 36". SCALE RATIO IS NOT VALID FOR REDUCED OR ENLARGED SHEET SIZES

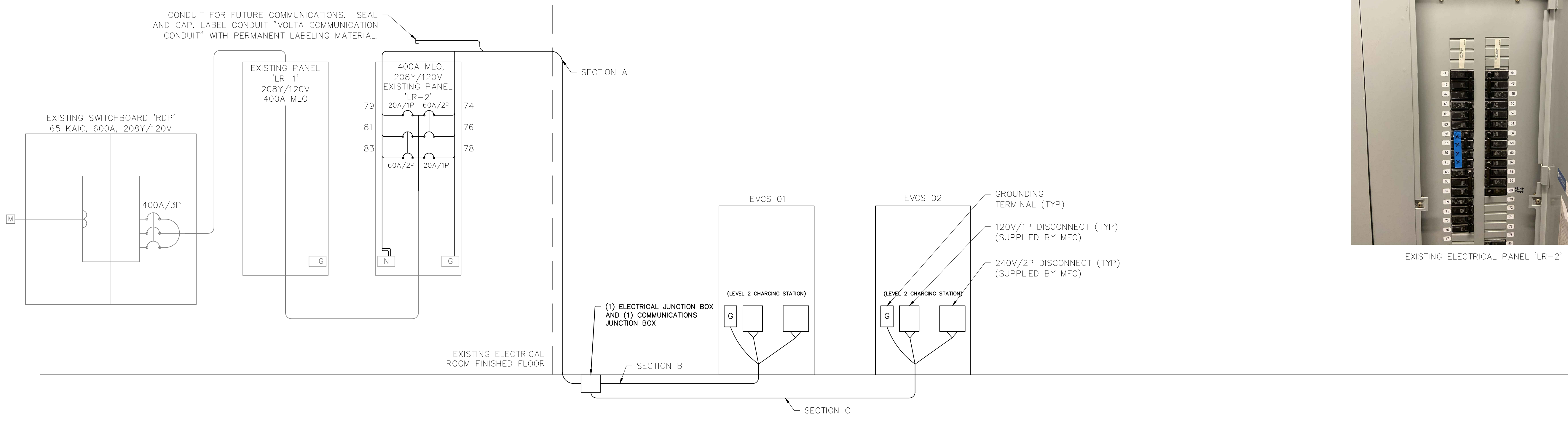

- NOTES:**
- ALL ELECTRICAL WORK AND RELATED ACTIVITIES PERFORMED ON SITE SHALL BE DONE IN ACCORDANCE WITH NATIONAL ELECTRICAL CODE (NEC) STANDARDS BEING ENFORCED BY ALL APPLICABLE JURISDICTIONAL REQUIREMENTS AT THE TIME OF CONSTRUCTION.
  - ANY PAVEMENT DAMAGED DURING CONSTRUCTION SHALL BE REPAIRED OR REPLACED BY THE CONTRACTOR TO PRE-CONSTRUCTION CONDITIONS OR BETTER.
  - CONTRACTOR SHALL USE THWN COPPER CONDUCTORS.
  - CONTRACTOR SHALL USE EMT INSIDE AND OUTSIDE ABOVE GRADE WHERE NOT SUBJECT TO DAMAGE. CONTRACTOR SHALL RGS INSIDE AND OUTSIDE ABOVE GRADE WHERE SUBJECT TO DAMAGE. CONTRACTOR SHALL USE PVC SCHEDULE 80 BELOW GRADE.
  - SEE SHEETS C1-00 AND C2-00 FOR CONDUIT STUB UP LOCATIONS.
  - CONTRACTOR TO LOCATE JUNCTION BOX, CONDUIT PULLING POINT, OR APPROVED ALTERNATIVE FOR SITE SPECIFIC RUN LENGTHS AND BENDS.
  - THE CONTRACTOR SHALL PERFORM A 30-DAY LOAD STUDY ON PANEL "LR-1"/"LR-2" FEEDER BREAKER ON THE SWITCHBOARD. THE LOAD STUDY SHALL UTILIZE A METERING DEVICE THAT CAN MEASURE AND RECORD THE PEAK DEMAND ON EACH PHASE CONDUCTOR AND THE NEUTRAL CONDUCTOR EVERY 15 MINUTES OVER THE DURATION OF THE 30-DAY PERIOD. THE RESULTS SHALL BE SUBMITTED TO THE ENGINEER FOR APPROVAL EITHER IN .XLSX FORMAT WITH DATE, TIME, PHASE COLUMNS AND RECORDED PEAK DEMAND OR IN PLOTTED FORMAT FOR EACH PHASE AND NEUTRAL WITH AMPS SHOWN ON THE Y-AXIS AND TIME ON THE X-AXIS. ON THE RESULTS SUBMITTAL, INCLUDE THE NAME OF THE ELECTRICIAN, THE DAYS THE LOAD STUDY STARTED AND FINISHED, AND THE NAME OF THE PANEL THAT THE LOAD STUDY IS BEING PERFORMED ON. THE CONTRACTOR SHALL NOT PROCEED WITH ANY MODIFICATIONS AND/OR ADDITIONS UNTIL WRITTEN APPROVAL IS RENDERED FROM THE ENGINEER.

Panel Schedule														
Existing Panel "LR-2" Location: Existing Electrical Room Volls: 208Y/120V Phase: 3 Wire: 4 Hertz: 60														
400A MLO Main AIC: N/A Branch AIC: (See Note 3) ENCL. (NEMA): 1 MTG. Surface														
400 Amp Frame, Ground Bar, Locking Cover, Panel Card														
Description of Load Served	Breaker		Wire	A/Phase			CKT No	CKT No	A/Phase			Breaker	Description of Load Served	
	Amp	Pole		A	B	C			A	B	C			Amp
SPACE							43	44					SPACE	
SYSTEM DLT19 DEFROST	30	3	EXIST	EX			45	46					SYSTEM DLT12 DEFROST	
					EX		47	48						
SPARE							49	50	EX				SYSTEM DLT13 DEFROST	
						EX	51	52		EX				
SPARE							53	54	EX		EX		SYSTEM DLT21 DEFROST	
						EX	55	56		EX				
SYSTEM DLT21 DEFROST	20	3	EXIST				57	58					SYSTEM DLT22 DEFROST	
						EX	59	60		EX				
PANEL DLT	20	2	EXIST				61	62	EX				SPACE	
						EX	63	64		EX				
EXISTING LOAD	20	2	EXIST				65	66			EX		SPACE	
						EX	67	68		-				
CHARGING STATION EV01	20	1	See Note 5				69	70					CHARGING STATION EV02	
						EX	71	72		-				
CHARGING STATION EV01	60	2	See Note 5				73	74	48.0		See Note 5	60	2	DLT20 COND UNIT
						EX	75	76		48.0		See Note 5	20	
CHARGING STATION EV02							77	78		5.0	See Note 5	20	1	CHARGING STATION EV02
						EX	79	80		EX				
							81	82						
							83	84						
Total A/Phase				5.0	48.0	48.0				48.0	48.0	5.0	Total A/Phase	

Notes:

- Connected KVA (New): 24.2
- Demand KVA (New): 30.3
- Contractor shall match existing AIC Rating.
- Where load is labeled "EX" the load is unknown.
- See Voltage Drop Table for conductor sizing.

L2 Conductor Voltage Drop Table Per Charging Station										
<175FT	175FT-200FT	200FT-255FT	255FT-275FT	275FT-320FT	320FT-400FT	400FT-440FT	440FT-510FT	510FT-635FT	635FT-700FT	700FT-800FT
(2) #4 AWG +	(2) #4 AWG +	(2) #3 AWG +	(2) #2 AWG +	(2) #2 AWG +	(2) #1 AWG +	(2) #1/0 AWG +	(2) #1/0 AWG +	(2) #2/0 AWG +	(2) #3/0 AWG +	(2) #3/0 AWG +
(2) #12 AWG +	(2) #10 AWG +	(2) #10 AWG +	(2) #10 AWG +	(2) #8 AWG +	(2) #8 AWG +	(2) #8 AWG +	(2) #6 AWG +	(2) #6 AWG +	(2) #4 AWG +	(2) #4 AWG +
(1) #6 AWG GND	(1) #6 AWG GND	(1) #4 AWG GND	(1) #4 AWG GND	(1) #4 AWG GND	(1) #4 AWG GND	(1) #3 AWG GND	(1) #3 AWG GND	(1) #2 AWG GND	(1) #1 AWG GND	(1) #1 AWG GND

- VOLTAGE DROP TABLE NOTES
- CONTRACTOR SHALL BE RESPONSIBLE FOR DE-RATING CONDUCTORS WHEN 4 OR MORE CURRENT CARRYING CONDUCTORS ARE CARRIED IN THE SAME CONDUIT PER THE NEC.
  - THE DISTANCES IN THIS TABLE ARE TOTAL DISTANCES, NOT HORIZONTAL DISTANCES. INCLUDE VERTICAL RUNS AND JUNCTION BOX COIL LENGTH IN THE TOTAL CONDUCTOR DISTANCE.
  - WHEN MORE THAN ONE CHARGING STATION CIRCUIT CONDUCTORS ARE IN A CONDUIT, USE ONLY ONE SHARED EQUIPMENT GROUND CONDUCTOR.
  - WHEN THERE IS A REMOTE HOLSTER, INSTALL (2) #6 AWG + (1) #8 AWG GND + (1) #14 AWG COMM IN THE CONDUIT FROM EVCS TO REMOTE HOLSTER.
  - WHEN INSTALLING #1/0 AWG OR LARGER CONDUCTORS FROM THE POWER SOURCE TO EVCS, INCLUDE MULTICONDUCTOR TAPS IN THE CLOSEST JUNCTION BOX PRIOR TO ENTERING THE EVCS OR IN THE EVCS ITSELF SO THAT #6 AWG CONDUCTORS CAN BE TERMINATED IN THE EVCS.

Conduit Schedule			
Conduit Section	Conduit #	Conduit Size	Installation Method
A	1	2"	(See Voltage Drop Table)
	2	3/4" Min	Future Communications w/ Pull String
B	1	2"	(See Voltage Drop Table)
	2	3/4" Min	Future Communications w/ Pull String
C	1	2"	(See Voltage Drop Table)
	2	3/4" Min	Future Communications w/ Pull String

**VOLTA**

155 DE HARO STREET  
SAN FRANCISCO, CA 94103

**Kimley»Horn**

1 N LEXINGTON AVE, SUITE 505  
WHITE PLAINS, NY 10601  
Main: 914.368.9200 | www.kimley-horn.com  
© 2021 Kimley-Horn and Associates, Inc.

REV	DATE	DESCRIPTION	BY
1	03/03/2021	CD90s	TAS
2	05/05/2021	CD100s	TAS
3	07/21/2021	CD100s	TAS

ISSUE DATE

**05/05/2021**

ISSUED FOR

**PERMIT**

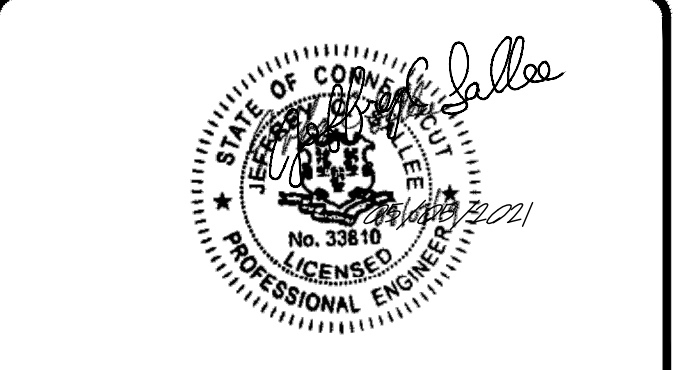

IT IS A VIOLATION OF LAW FOR ANY PERSON, UNLESS THEY ARE ACTING UNDER THE DIRECTION OF A LICENSED PROFESSIONAL ENGINEER, TO ALTER THIS DOCUMENT.

**STOP & SHOP #2604 TORRINGTON**

**931 TORRINGTON STREET TORRINGTON, CT 06790**

SHEET TITLE

**ELECTRICAL ONE LINE DIAGRAM & PANEL SCHEDULE**

SHEET NUMBER

**E1-00**

NOTE: THE ORIGINAL SIZE OF THIS PLAN IS 24" X 36". SCALE RATIO IS NOT VALID FOR REDUCED OR ENLARGED SHEET SIZES.

NOTE: THE ORIGINAL SIZE OF THIS PLAN IS 24" X 36". SCALE RATIO IS NOT VALID FOR REDUCED OR ENLARGED SHEET SIZES

- NOTES:**
1. A NATIONALLY RECOGNIZED TESTING LABORATORY SHALL LIST ALL EQUIPMENT IN COMPLIANCE WITH ART110.3.
  2. ALL EXTERIOR EQUIPMENT SHALL BE RAIN TIGHT AND APPROVED FOR USE IN WET CONDITIONS.
  3. ALL CONDUCTORS SHALL BE PROVIDED WITH STRAIN RELIEF UPON ENTRY INTO ENCLOSURES.
  4. EACH UNGROUNDED CONDUCTOR SHALL BE IDENTIFIED BY PHASE AND SYSTEM PER ART 210.5.
  5. ALL METALLIC COMPONENTS SHALL BE GROUNDED VIA EQUIPMENT GROUNDING CONDUCTORS.
  6. CHARGING UNITS ARE EQUIPPED WITH AN INTEGRATED CONTRACTOR TO PREVENT BACK FEEDING OF POWER TO THE SOURCE.
  7. CONTRACTOR TO FIELD VERIFY MAIN FEED BREAKER SUPPORTING DISTRIBUTION PANEL IS APPROPRIATELY SIZED TO SUPPORT THE LOAD. CONTRACTOR SHALL CONTACT THE ENGINEERING TEAM IMMEDIATELY IF BREAKER IS FOUND TO BE INSUFFICIENT.
  8. CONTRACTOR SHALL INSPECT ALL PRE-WIRED CONNECTIONS WITHIN EACH CHARGING STATION TO ENSURE THE CONNECTIONS ARE SOLID. INFORM VOLTA OR THE ENGINEER IF ANY CONNECTIONS ARE LOOSE OR DAMAGED.

- ABBREVIATIONS:**
- A AMPERE
  - AC ALTERNATING CURRENT
  - AL ALUMINUM
  - ART ARTICLE
  - AUX AUXILIARY
  - BLDG BUILDING STRUCTURE
  - CONC CONCRETE
  - CU COPPER
  - DC DIRECT CURRENT
  - EGC EQUIPMENT GROUNDING CONDUCTOR
  - (E) EXISTING
  - EMT ELECTRIC METALLIC TUBING
  - EV ELECTRIC VEHICLE
  - EVSE ELECTRIC VEHICLE SUPPLY EQUIPMENT
  - GALV GALVANIZED
  - GND GROUND
  - HDG HOT DIPPED GALVANIZED
  - I CURRENT
  - KVA KILOVOLT AMPERE
  - KW KILOWATT
  - M METER
  - MAX MAXIMUM
  - MIN MINIMUM
  - N NEUTRAL
  - NEC NATIONAL ELECTRIC CODE
  - NTS NOT TO SCALE
  - (N) NEW
  - OC ON CENTER
  - PL PROPERTY LINE
  - PVC POLYVINYL CHLORIDE
  - RMC RIGID METALLIC CONDUIT
  - SCH SCHEDULE
  - SS STAINLESS STEEL
  - TYP TYPICAL
  - V VOLT
  - W WATT
  - XFMR TRANSFORMER

- ELECTRICAL NOTES:**
1. ALL ELECTRICAL WORK AND RELATED ACTIVITIES PERFORMED ON-SITE SHALL BE DONE IN ACCORDANCE WITH NATIONAL ELECTRIC CODE (NEC) STANDARDS BEING ENFORCED BY ALL APPLICABLE JURISDICTIONAL REQUIREMENTS AT THE TIME OF CONSTRUCTION.
  2. UTILITY EQUIPMENT INSTALLATIONS AND PREP WORK SHALL BE COORDINATED WITH THE APPROPRIATE UTILITY ENGINEER AT TIME OF PRECONSTRUCTION MEETING TO ENSURE ACCURACY OF INSTALLATIONS.
  3. CONDUIT PATHS ARE REPRESENTATIVE ONLY. EXACT CONDUIT PLACEMENT TO BE DETERMINED ON SITE BASED ON FIELD CONDITIONS.
  4. CONTRACTOR SHALL TAKE NECESSARY PRECAUTIONS WHEN DRILLING INTO EXISTING CIP SLAB AND CIP DROP PANELS TO AVOID DAMAGE TO ANY REINFORCING AND EXISTING STRUCTURAL COMPONENTS.
  5. USE APPROVED ASTM METHOD (X-RAY, PACOMETER, GPR, ETC.) TO LOCATE MILD STEEL AND PRE-STRESSING TENDONS PRIOR TO DRILLING. DO NOT CUT OR DRILL THROUGH ANY EXISTING REINFORCING. ADJUST LOCATION AS NECESSARY TO AVOID EXISTING REINFORCING.
  6. PRIOR TO DRILLING, CONTRACTOR SHALL VERIFY THICKNESS OF EXISTING CONCRETE WALL IS AT LEAST 9" AND THAT 6" ANCHOR EMBEDMENT CAN BE PROVIDED.
  7. REFER TO CIVIL PLANS FOR WALL MOUNT LOCATIONS.

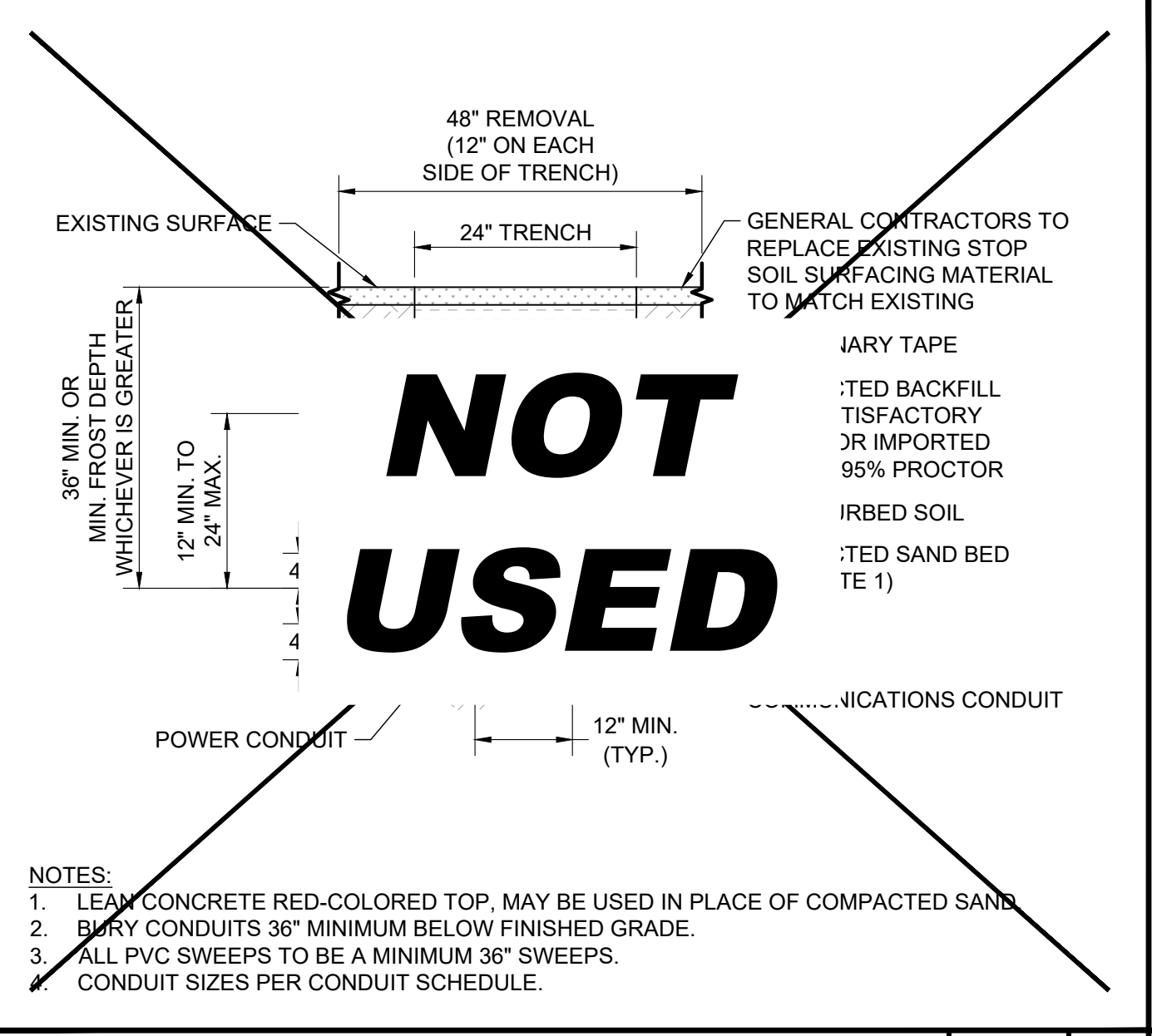

**POWER TRENCH** SCALE N.T.S. 2

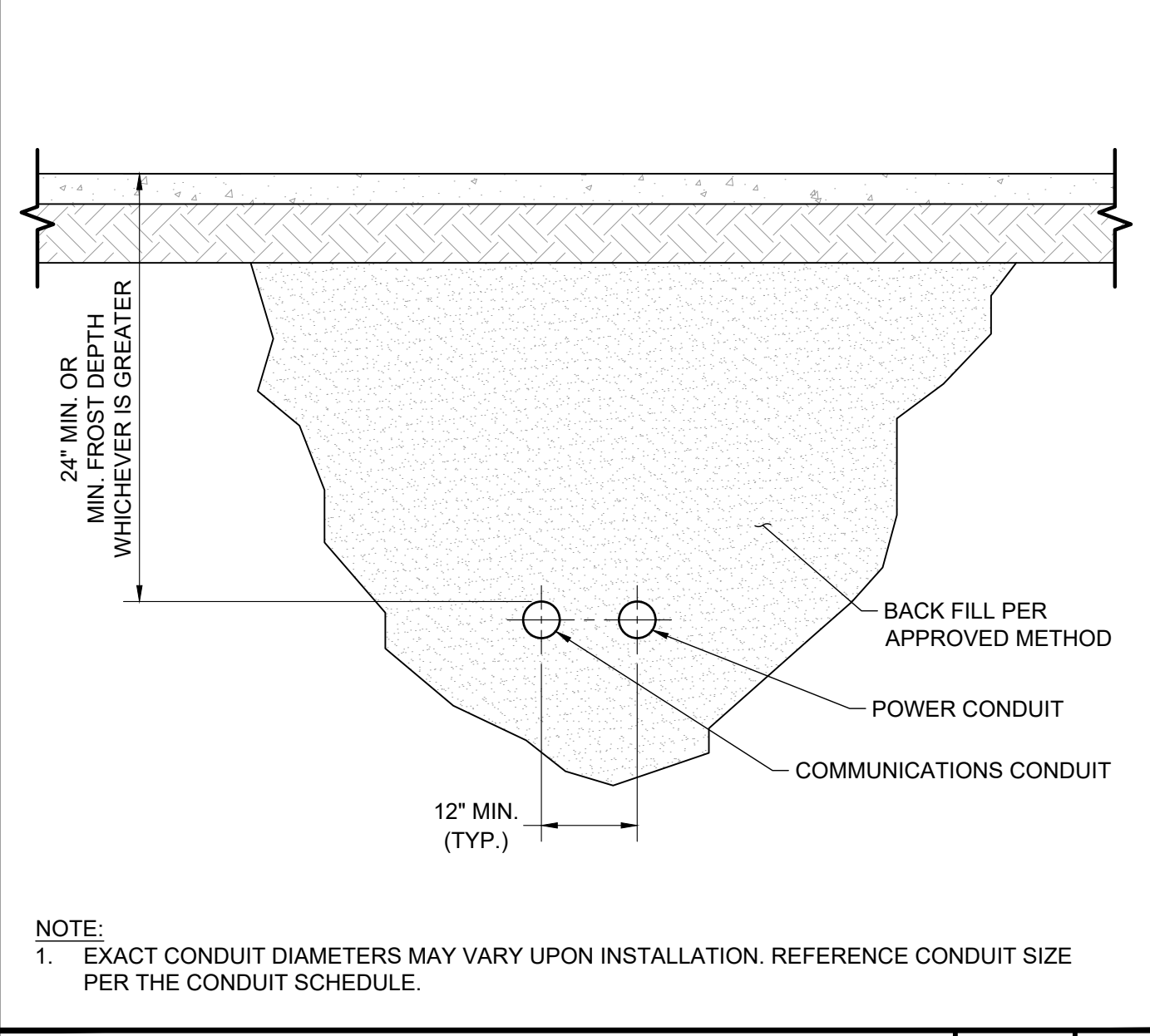

**BORE SECTION** SCALE N.T.S. 3

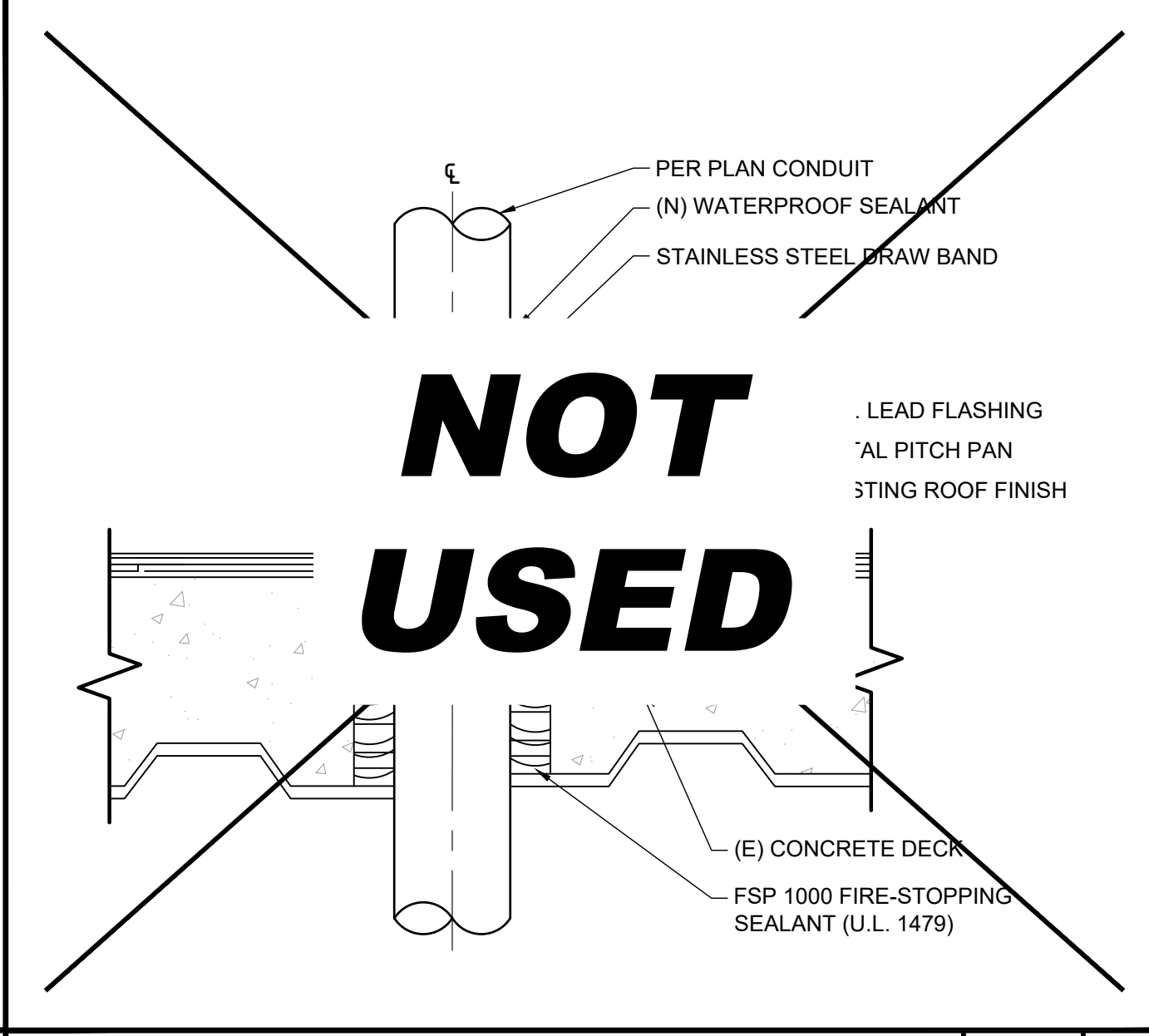

**CORE DETAIL** SCALE N.T.S. 4

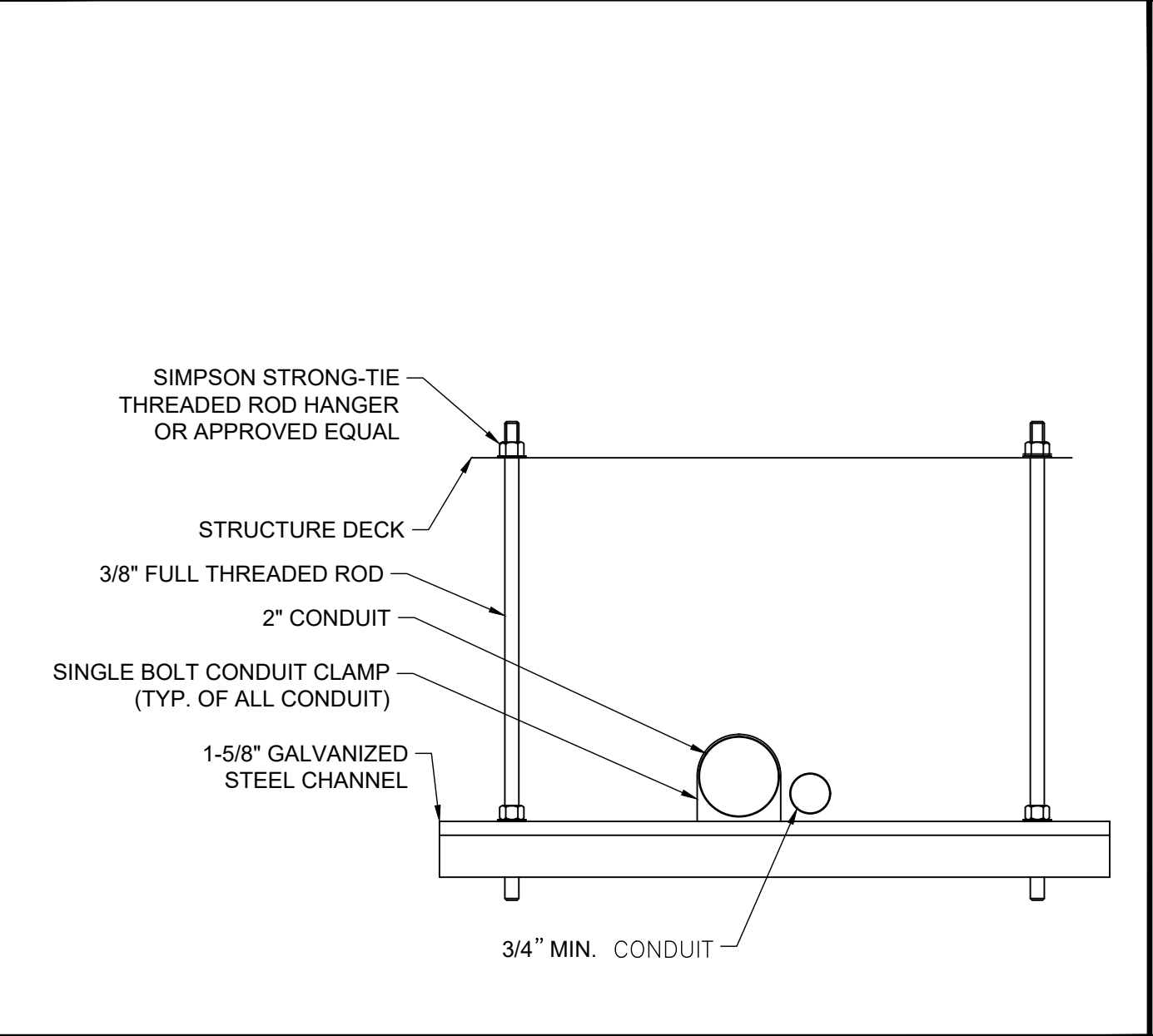

**CEILING CONDUIT SUPPORT** SCALE N.T.S. 5

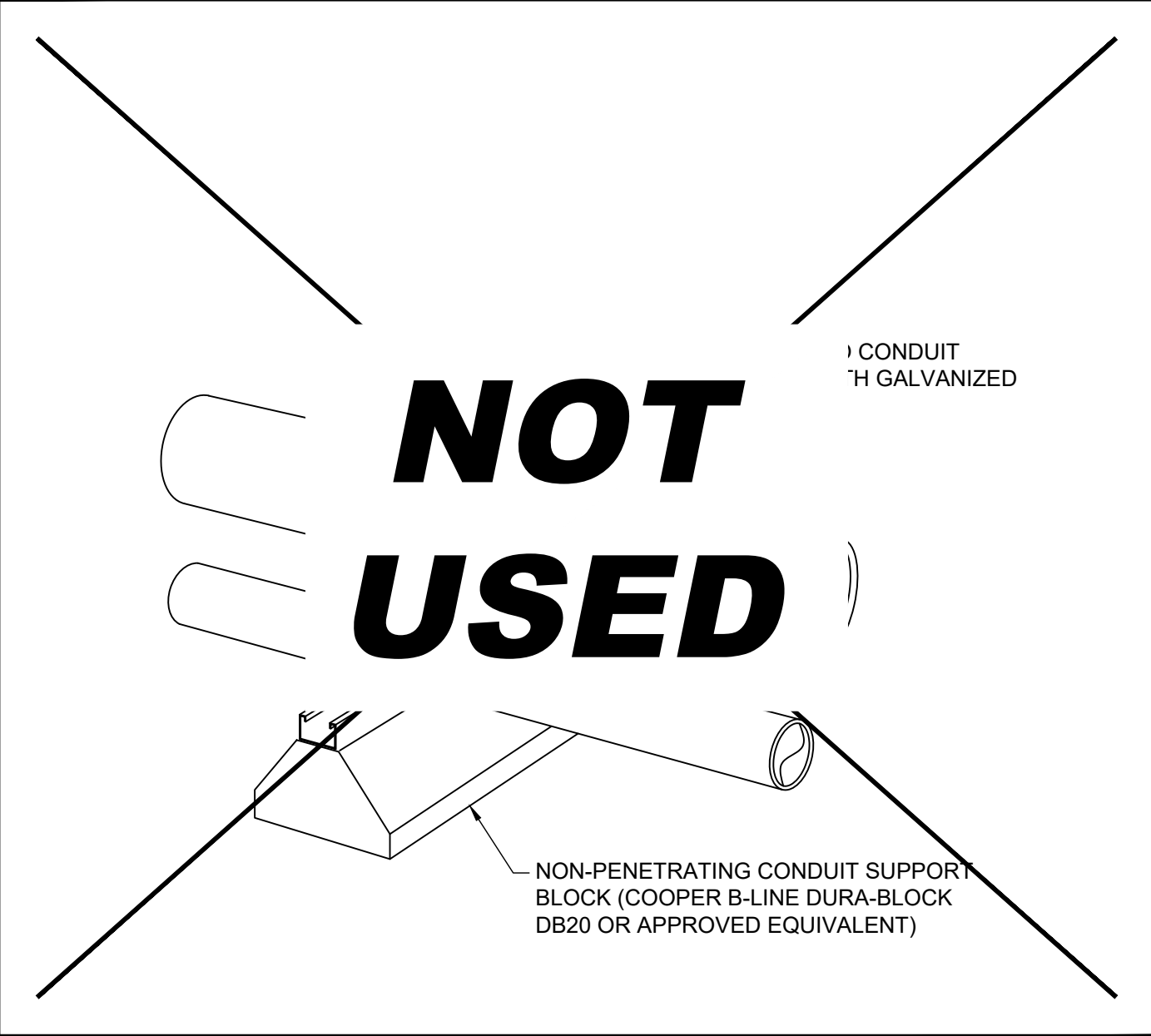

**ROOFTOP CONDUIT SUPPORT** SCALE N.T.S. 6

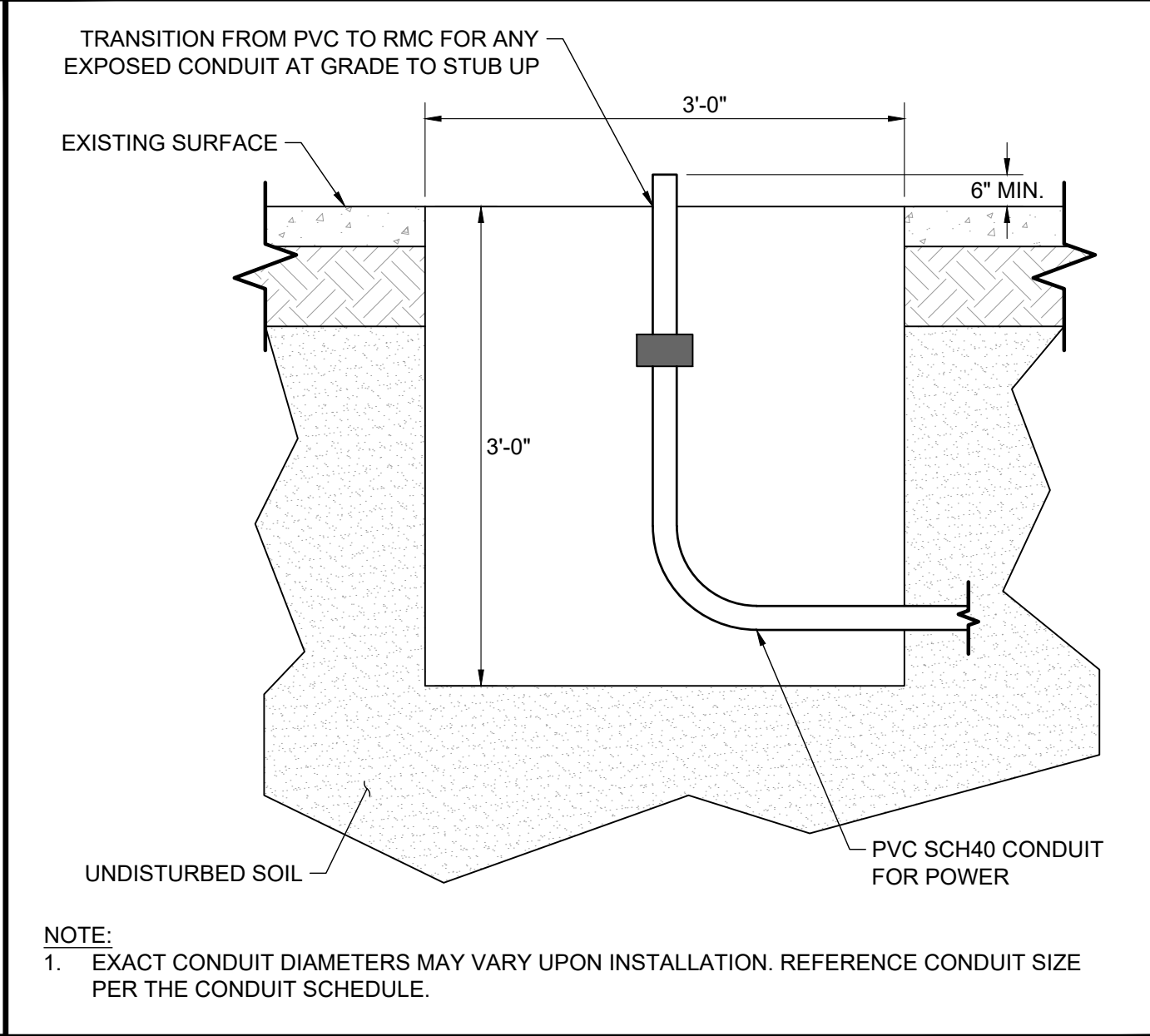

**BORE PIT** SCALE N.T.S. 7

**ELECTRICAL NOTES & ABBREVIATIONS** 1

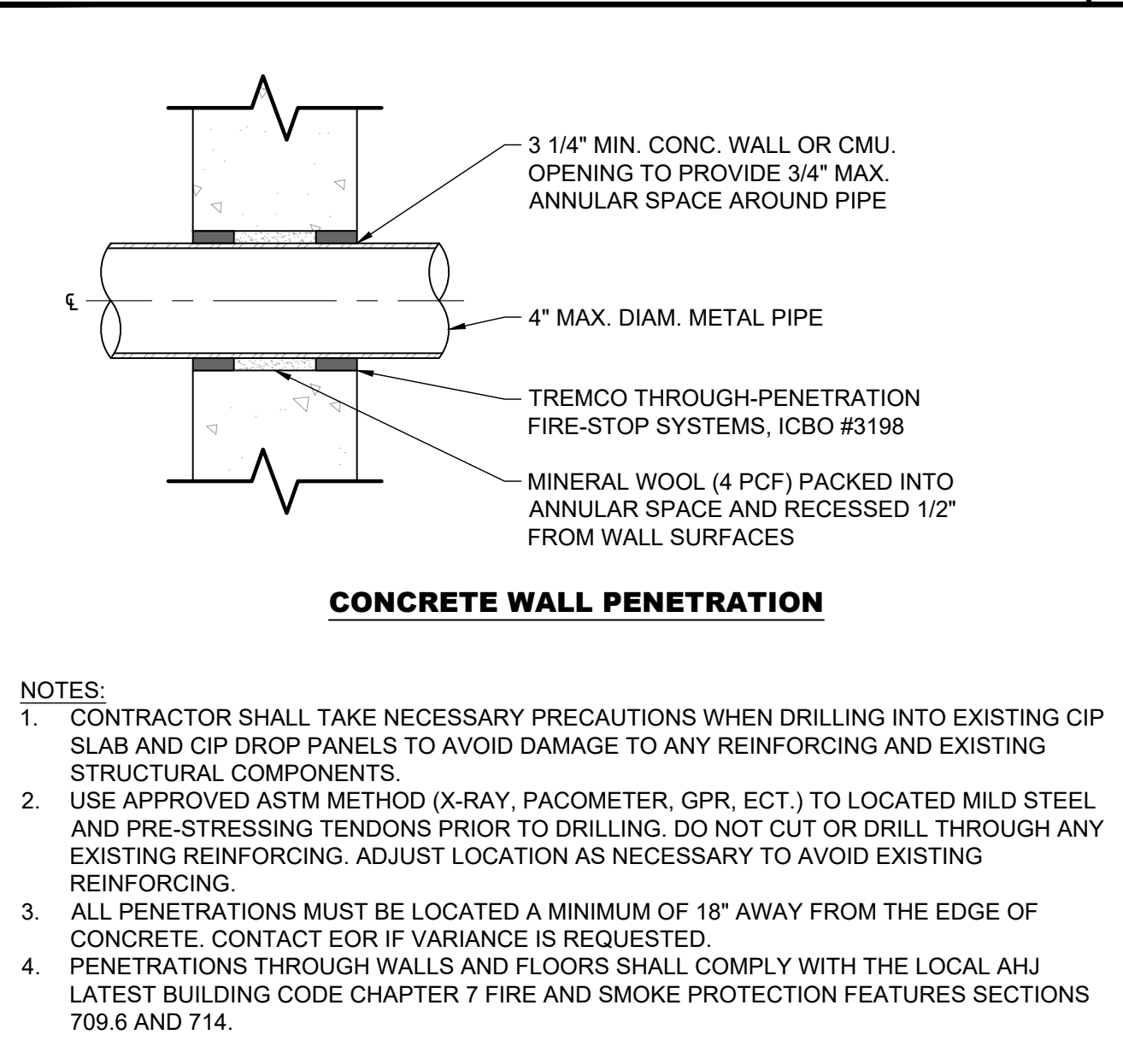

**PENETRATION DETAIL** SCALE N.T.S. 8

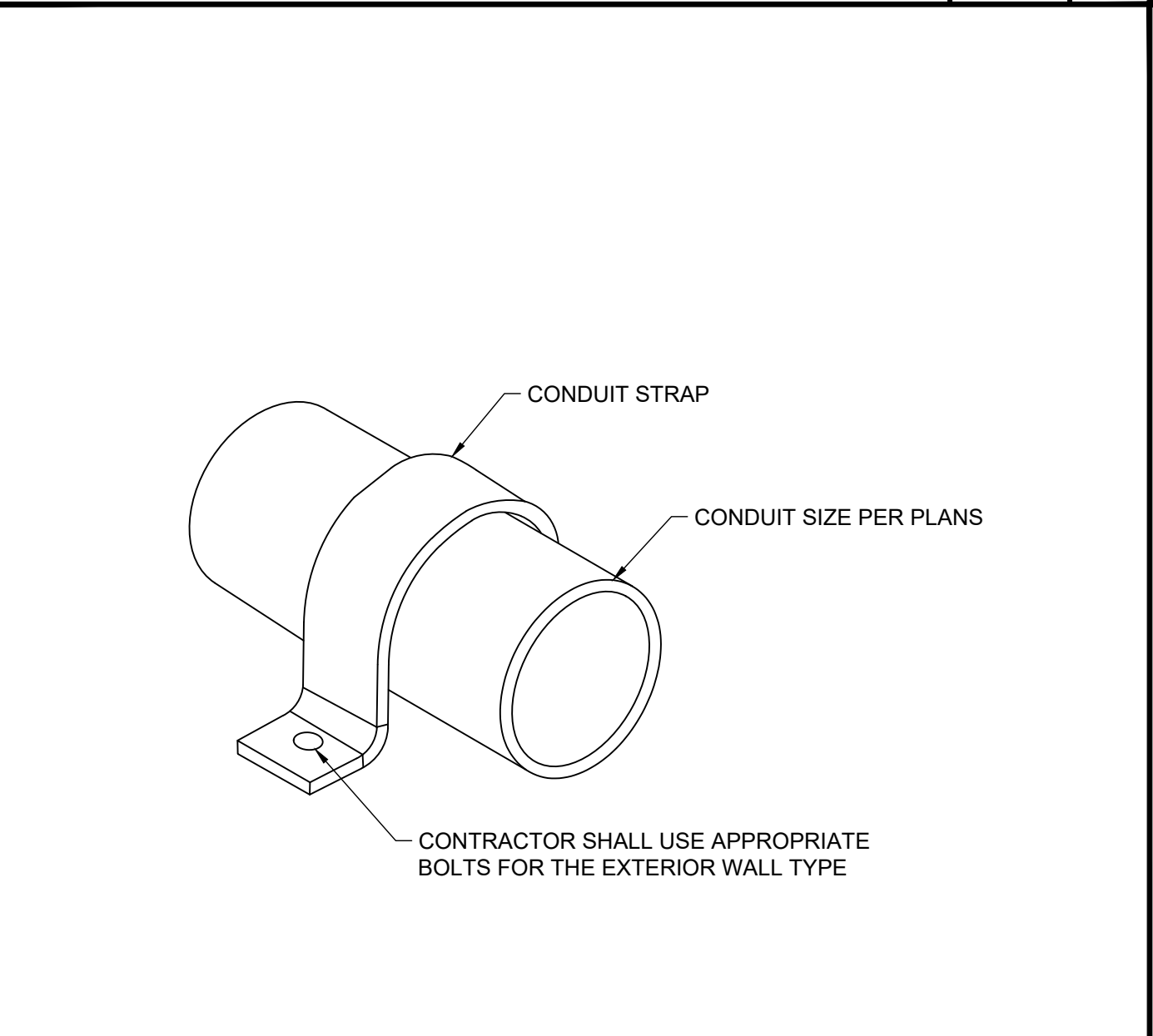

**WALL CONDUIT MOUNT STRAP** SCALE N.T.S. 9

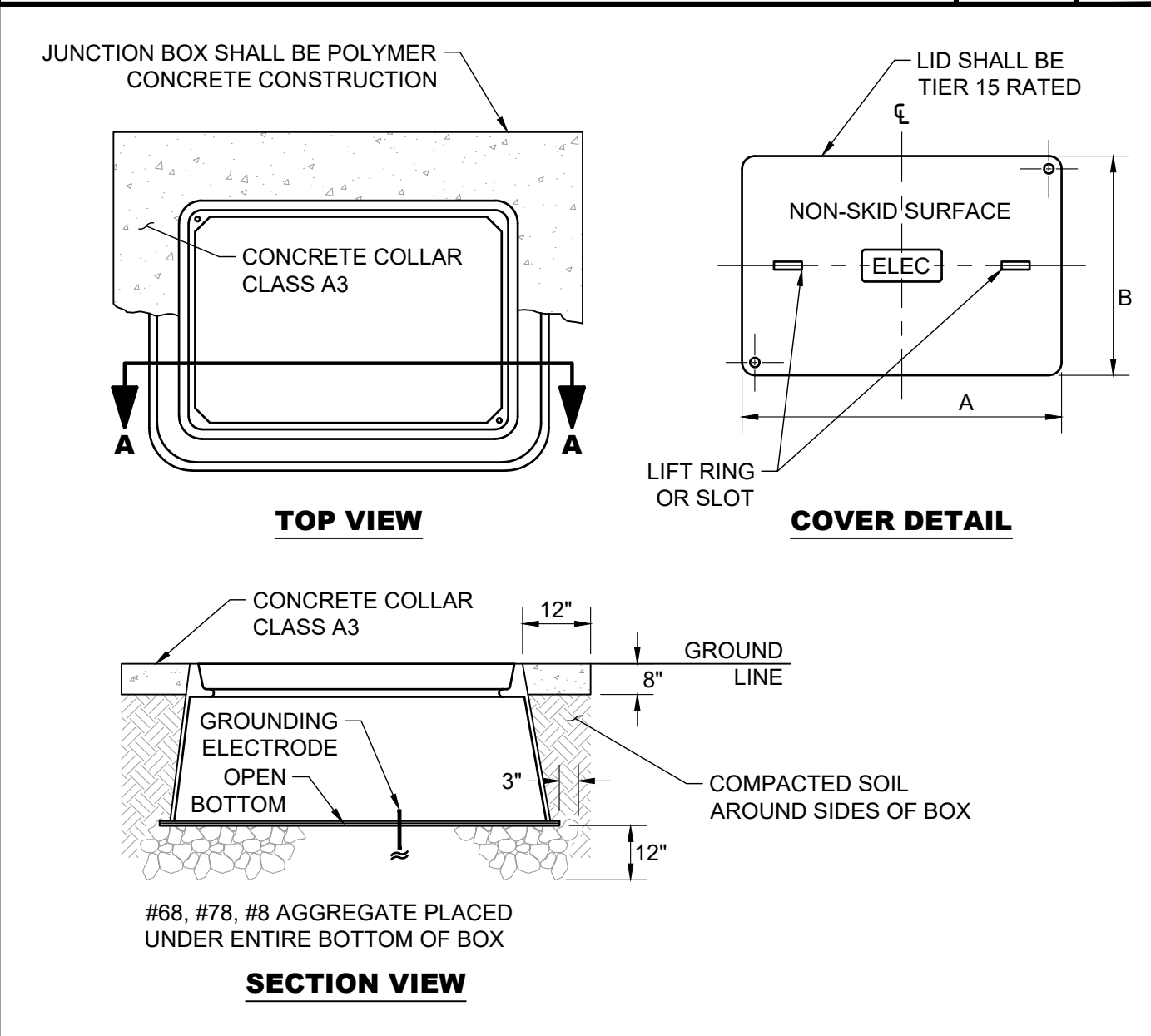

**NON-TRAFFIC RATED JUNCTION BOX** SCALE N.T.S. 10

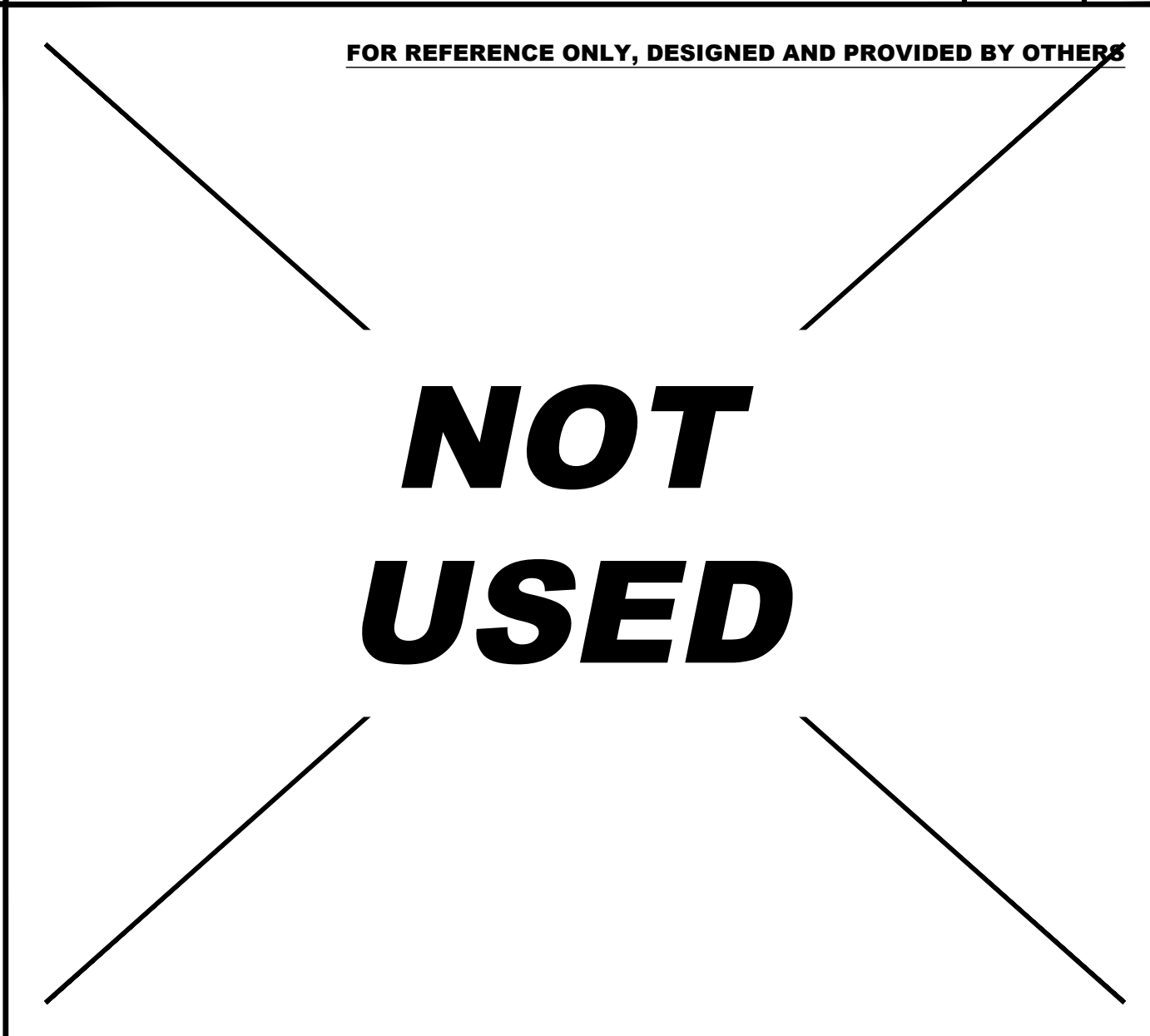

**BTC POLE DISCONNECT SWITCH** SCALE N.T.S. 11

**VOLTA**  
155 DE HARO STREET  
SAN FRANCISCO, CA 94103

**Kimley»Horn**  
1 N LEXINGTON AVE, SUITE 505  
WHITE PLAINS, NY 10601  
Main: 914.368.9200 | www.kimley-horn.com  
© 2021 Kimley-Horn and Associates, Inc.

REV	DATE	DESCRIPTION	BY
1	03/03/2021	CD90s	TAS
2	05/05/2021	CD100s	TAS
3	07/21/2021	CD100s	TAS

ISSUE DATE  
**05/05/2021**

ISSUED FOR  
**PERMIT**

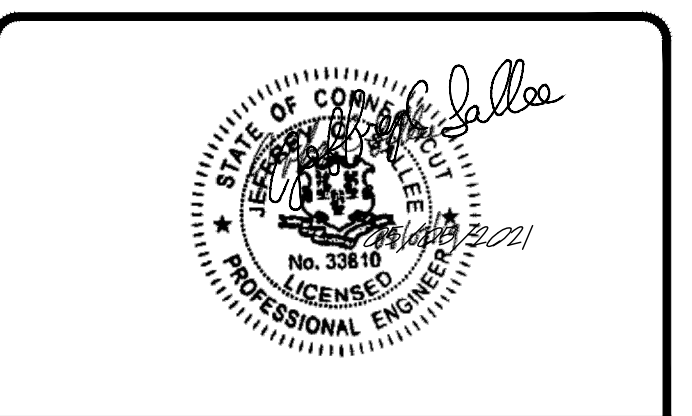

IT IS A VIOLATION OF LAW FOR ANY PERSON, UNLESS THEY ARE ACTING UNDER THE DIRECTION OF A LICENSED PROFESSIONAL ENGINEER, TO ALTER THIS DOCUMENT.

**STOP & SHOP #2604 TORRINGTON**  
931 TORRINGTON STREET  
TORRINGTON, CT 06790

SHEET TITLE  
**ELECTRICAL NOTES & DETAILS**

SHEET NUMBER  
**E2-00**